

Guidelines for the design, purchase and installation of Slant/Fin oil-fired steam modular boiler systems.

CONTENTS

Introduction	1	Steam piping design	9
Ratings and dimensions	2	Installation and piping	10,11
Boiler room air supply	3	Boiler feed pump sizing	12,13
Venting gas fired system	4,5	Wiring at module	14-17
Fuel oil piping	6,7	Request for Caravan rating plate.....	19-20
Typical steam system layout	9		

CODES AND STANDARDS

Oil-fired Caravan installations must comply to local codes or, in the absence of local codes, to the ANSI/NFPA 31, Installation of Oil Burning Equipment, latest edition.

In addition, where required by the authority having jurisdiction, the installation must conform to American Society of Mechanical Engineers Safety Codes for controls and safety devices for automatically fired boilers, No. CSD-1. The installation must also conform to the additional requirements of Slant/Fin Instruction Book publication no. TR-40 latest edition.

All electrical wiring is to be done in accordance with the National Electrical Code ANSI/NFPA No. 70-latest edition and all local electrical codes. The unit must be electrically grounded if an external power source is used.

In Canada, the installation must be in accordance with standards CGA B149.1 and B149.2, installation codes for oil burning appliances and equipment and/or local codes. All electrical connections are to be made in accordance with Standard C.S.A. C22.1 Canadian Electrical Code Part 1 and/or local codes.

INTRODUCTION OF FRESH WATER

Introduction of excessive amounts of fresh water into a system can cause scaling and leave deposits in the boiler and the surrounding pipes. This will lead to inefficient boiler operation and breakdown. Fresh water will enter the system as a result of hidden leaks such as may occur in underground piping. Relief valves should be piped to a location that shows visible signs of relief.

Process applications that use fresh water, require the use of heat exchangers. Any process application that results in introduction of fresh water into a boiler can cause scaling with deposits forming in the boiler and surrounding piping. This will damage the boiler. Introduction of fresh water from leaks will cause similar damage. Use of fresh water will void warranty.

In some areas it may be necessary to use a feed water treatment to control the corrosive makeup of the feed water. Check with the local authority, to determine if the feed water will need a conditioning treatment before being supplied to the boiler.

INTRODUCTION

There are many varieties of steam heating systems. Because of the wide range of field conditions, the design of these systems is beyond the scope of this manual. However, when designing a steam Caravan boiler plant, certain guidelines should be followed that are common to all modular steam heating application.

This entire manual should be read prior to installing the Slant/Fin Caravan steam system.

Safety – each module contains a LW.CO, ASME 15 lb Relief valve and pressure gauge.



Ratings

Oil Caravan ratings and dimensions/steam models — LDZO Series

Model No.	No. of Heating Modules	Ratings for No. 2 Oil						Horse-power	Boiler Water Content (gal)	Weight with Water	Recommended Header Size
		AHRI									
		Burner Capacity (GPH)*	Input (MBH)	Gross Output MBH	Thermal Efficiency	Net Output MBH†	Net Sq.Ft Steam‡				
LDZO-600-2-5	2	4.3	602	497	82.5	373	1554	14.8	21.4	1426	3"
LDZO-750-2-6	2	5.2	728	622	85.5	467	1946	18.6	25.2	1630	3"
LDZO-850-2-7	2	6.0	840	699	83.2	526	2192	20.9	29.0	1838	4"
LDZO-900-3-5	3	6.4	896	740	82.5	555	2311	22.1	32.1	2139	4"
LDZO-1100-3-6	3	7.8	1092	934	85.5	700	2918	27.9	37.8	2445	5"
LDZO-1300-3-7	3	9.0	1260	1048	83.2	789	3287	30.6	43.5	2756	5"
LDZO-1700-4-7	4	12.0	1680	1398	83.2	1051	4379	41.8	58.0	3675	6"
LDZO-2100-5-7	5	15.0	2100	1747	83.2	1314	5474	52.2	72.5	4594	6"

* Light oil, 140,000 Btu. per gallon.

† Net ratings are based on piping and pick-up allowance of 1.33. Slant/Fin should be consulted before selecting a boiler for installation having unusual piping and/or pick-up requirements. For higher elevations, input may need to be reduced

‡ Based on 240 Btu/h per square foot E.D.R. at 215°F average steam temperature.

Modules in excess of 5 are piped in parallel in two or more banks.

Dimensions

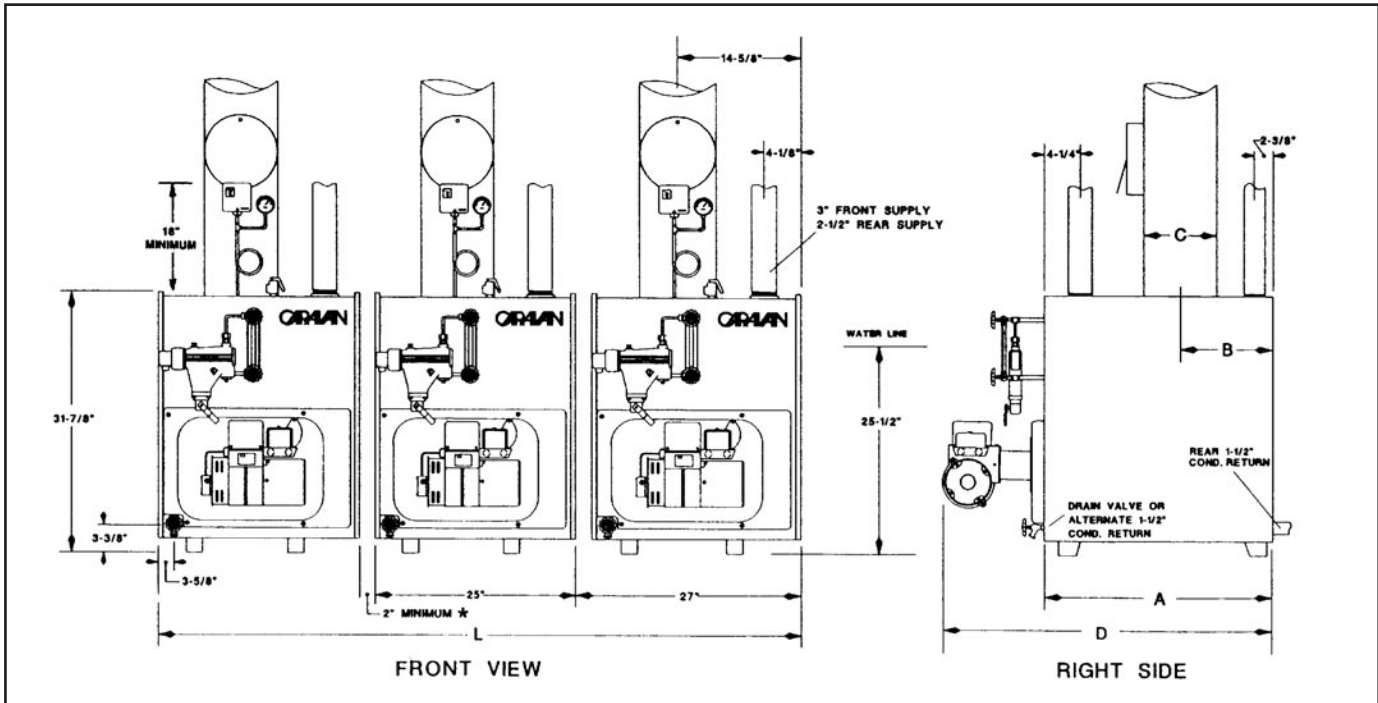

* CHECK LOCAL CODES TO VERIFY COMPLIANCE

Model No.	Dimensions*				
	A	B	C	D	L
LDZO-600-2-5	21 $\frac{5}{8}$ "	8 $\frac{7}{32}$ "	8"	34 $\frac{3}{8}$ "	4'4"
LDZO-750-2-6	25"	9 $\frac{29}{32}$ "	8"	37 $\frac{1}{4}$ "	4'4"
LDZO-850-2-7	28 $\frac{3}{8}$ "	11 $\frac{19}{32}$ "	9"	41 $\frac{1}{8}$ "	4'4"
LDZO-900-3-5	21 $\frac{5}{8}$ "	8 $\frac{7}{32}$ "	8"	34 $\frac{3}{8}$ "	6'7"
LDZO-1100-3-6	25"	9 $\frac{29}{32}$ "	8"	37 $\frac{1}{4}$ "	6'7"
LDZO-1300-3-7	28 $\frac{3}{8}$ "	11 $\frac{19}{32}$ "	9"	41 $\frac{1}{8}$ "	6'7"
LDZO-1700-4-7	28 $\frac{3}{8}$ "	11 $\frac{19}{32}$ "	9"	41 $\frac{1}{8}$ "	8'10"
LDZO-2100-5-7	28 $\frac{3}{8}$ "	11 $\frac{19}{32}$ "	9"	41 $\frac{1}{8}$ "	11'1"

* Inches, except "L" which is feet/inches.

Design Data

Max. ASME Working Pressure: 15 psi steam
Power Requirements: 120 V/60 HZ,
6.0 amps per module

BOILER PLANT SIZING

Older buildings may have a heat loss significantly less than that of the original building. To size a replacement steam boiler plant, consider the following: Replacement steam boiler plants must be sized to match the connected radiation load. Under-sizing will prevent steam from reaching distant radiation quickly

BOILER ROOM DESIGN

Caravan modular boiler systems allow better utilization of floor space and permit future expansion with minimum cost. Caravan modules are hand truckable, fit through doorways and often may be installed around an existing inoperative boiler. They can be grouped in heating module batteries of single, multiple or angular rows. Oil-fired boiler systems consisting of 9 or more modules should be piped in parallel in two or more batteries. Illustrated below are typical boiler room layouts and dimensional data on the size requirements of oil-fired hot water boilers.

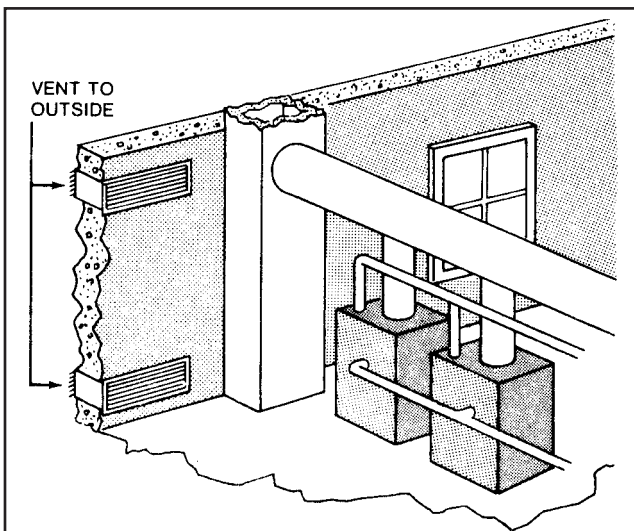

Figure 11. Correct location of combustion-air supply ducts

BOILER ROOM AIR SUPPLY

To ensure safe, efficient operation, the modular boiler system must be supplied with sufficient air to support complete combustion, replacing air entering draft dampers or draft hoods and ventilating the boiler room or areas. For additional information, not listed below, see ANSI, Z223.1, section 5.3.3.

INSTALLATION IN ENCLOSED BOILER ROOM REQUIRES TWO UNOBSTRUCTED OPENINGS FOR PASSAGE OF AIR INTO THE BOILER ROOM:

1. **Air drawn horizontally from outdoors DIRECTLY through an outside wall;** one louvered opening near the floor (below burner air inlet) and one louvered opening near the ceiling (above the highest draft regulator), each opening with a minimum FREE air passage area of **1 square inch per 4000 BTUH** of total system input.
2. **Air drawn horizontally from outdoors through HORIZONTAL DUCTS;** one opening near the floor (below burner inlet) and one opening near the ceiling (above the highest draft regulator), each opening with a minimum FREE air passage area of **1 square inch per 2000 BTUH** of total system input.
3. **Air drawn VERTICALLY from outdoors;** one opening at the floor and one opening at the ceiling, each opening with a minimum FREE air passage area of **1 square inch per 4000 BTUH** of total system input.
4. **Air drawn from inside the building;** one opening near the floor (below burner inlet) and one opening near the ceiling (above the highest draft regulator), each opening with a minimum FREE air passage area of **1 square inch per 1000 BTUH** of total system input.

IF BOILERS ARE INSTALLED ADJACENT TO OTHER FUEL BURNING EQUIPMENT, THE AREA OF FREE OPENINGS MUST BE APPROPRIATELY INCREASED TO ACCOMMODATE THE ADDITIONAL LOAD.

UNLESS PROPERLY CONTROLLED, AVOID THE USE OF FORCED VENTILATION, SINCE IT CAN CREATE AN UNDESIRABLE PRESSURE DIFFERENTIAL BETWEEN BOILER ROOM AND AIR SOURCE.

VENTING A OIL-FIRED SYSTEM

A boiler venting system provides draft and an escape path for the products of combustion. In a venting system for an oil-fired Caravan, there are three major components: a riser with draft regulator for each module, a breeching manifold, and a chimney.

Sometimes the venting system for a boiler plant has to be designed to compensate for inadequate chimney conditions. A mechanical draft inducer, properly sized and installed, can usually increase chimney capacity sufficiently to provide proper venting. Where a draft inducer is called for, consult local codes and the recommendations of the mechanical draft inducer manufacturer. Normally, a draft proving device is necessary to permit operation of the boilers only when adequate draft exists.

It is important to note that when considering a mechanical draft inducer, the boiler room air supply requirements must be increased. Consult the draft inducer manufacturer for this information.

Draft Regulator

The draft regulator compensates for excessive draft that can be caused by varying weather conditions. The regulator should be of the barometric-draft type. Once adjusted for a particular venting system, this type regulator automatically compensates for excessive draft to assure optimum operating efficiency.

Breeching

Breeching is a term used to describe a manifold(s) that connects individual boiler modules to a chimney. Breeching is usually constructed of sheet metal having a smooth interior surface with all joints made tight against leakage. The layout of a particular boiler room may require that the modules be arranged in "batteries" with rows either parallel or at right angles. Minimum breeching sizes are given in Table 3.

Table 3. Breeching dimensions for oil-fired systems — LDZO Series

Model No. *	No. of Modules	Breeching Diameter	Minimum Area (sq.in.)	Breeching Length
LDZO-600-2-5	2	11"	84	4'8"
LDZO-750-2-6	2	12"	101	4'8"
LDZO-850-2-7	2	13"	115	4'8"
LDZO-900-3-5	3	13"	123	7'1"
LDZO-1100-3-6	3	14"	148	7'1"
LDZO-1300-3-7	3	15"	170	7'1"
LDZO-1700-4-7	4	16"	189	9'6"
LDZO-2100-5-7	5	18"	233	11'11"

* Dual fuel prefix = LWDF.

Notes:

- For breeching and chimney sizing over 8 modules, consult factory.
- Breeching length should be as short as possible. Measurement from the base of the vertical vent to the nearest connected appliance should be limited to 10' or 50% of the total vent height, whichever is greater.

To avoid creating turbulent air patterns in the breeching, it is suggested that individual boiler vent pipes be connected to the breeching as indicated in Figure 13.

The breeching manifold should extend into, but not beyond, the chimney liner. Round breeching is preferable to rectangular breeching.

Chimney

Caravan oil-fired modular boilers operate efficiently with masonry or prefabricated chimneys. This latter type of chimney construction is generally the least expensive.

Minimum chimney sizes and heights are given in Table 4. In addition, the chimney should be high enough to minimize the effects of turbulent winds and high pressure areas common near roof-top obstructions. The National Board of Fire Underwriters recommends that the chimney should extend 3 feet above the roof and be 2 feet higher than any obstruction within 10 feet (figure 13). The use of a vent cap where permitted by code gives additional protection against adverse wind conditions and precipitation.

Table 4. Chimney requirements

Model No. *	No. of Modules	Chimney Liner Inside Dim. †		
		Dia. Inches	Rectangular L x W Inches	Minimum Height Feet
LDZO-600-2-5	2	11"	9¾" X 9¾"	20'
LDZO-750-2-6	2	12"	9½" X 13½"	20'
LDZO-850-2-7	2	13"	13¼" X 13¼"	20'
LDZO-900-3-5	3	13"	13¼" X 13¼"	20'
LDZO-1100-3-6	3	14"	13¼" X 13¼"	20'
LDZO-1300-3-7	3	15"	13" X 17"	20'
LDZO-1700-4-7	4	16"	13" X 17"	25'
LDZO-2100-5-7	5	18"	16¾" X 16¾"	25'

Sizing Horizontal Breeching Connectors and Chimneys for Oil-Fired Systems

* Dual fuel prefix = LWDF.

† Dimensions shown are from ASHRAE Guide Equipment Handbook. Also select inside liner dimensions to give area as great or greater than shown in this table. Chimney height is measured from the center line of the breeching to the top of the chimney. Chimney dimensions are approximate, with no manifold elbows or tees; and good vent construction practices. Field conditions vary. It is doubtful that the chimney dimensions shown here will be suitable for all applications. Consult the 2000 ASHRAE Equipment Handbook and Chimney Manufacturers Sizing Handbook.

Horizontal breeching connectors shall be constant sized. The chimney and the horizontal breeching connector are sized using table 3.

When there are multiple banks of boilers, the horizontal breeching connector for each bank is sized using table 3. To size the common horizontal breeching connector, add up the total input and refer to table 3 to size.

The minimum chimney will be equal to the size of the largest horizontal breeching section connected to it.

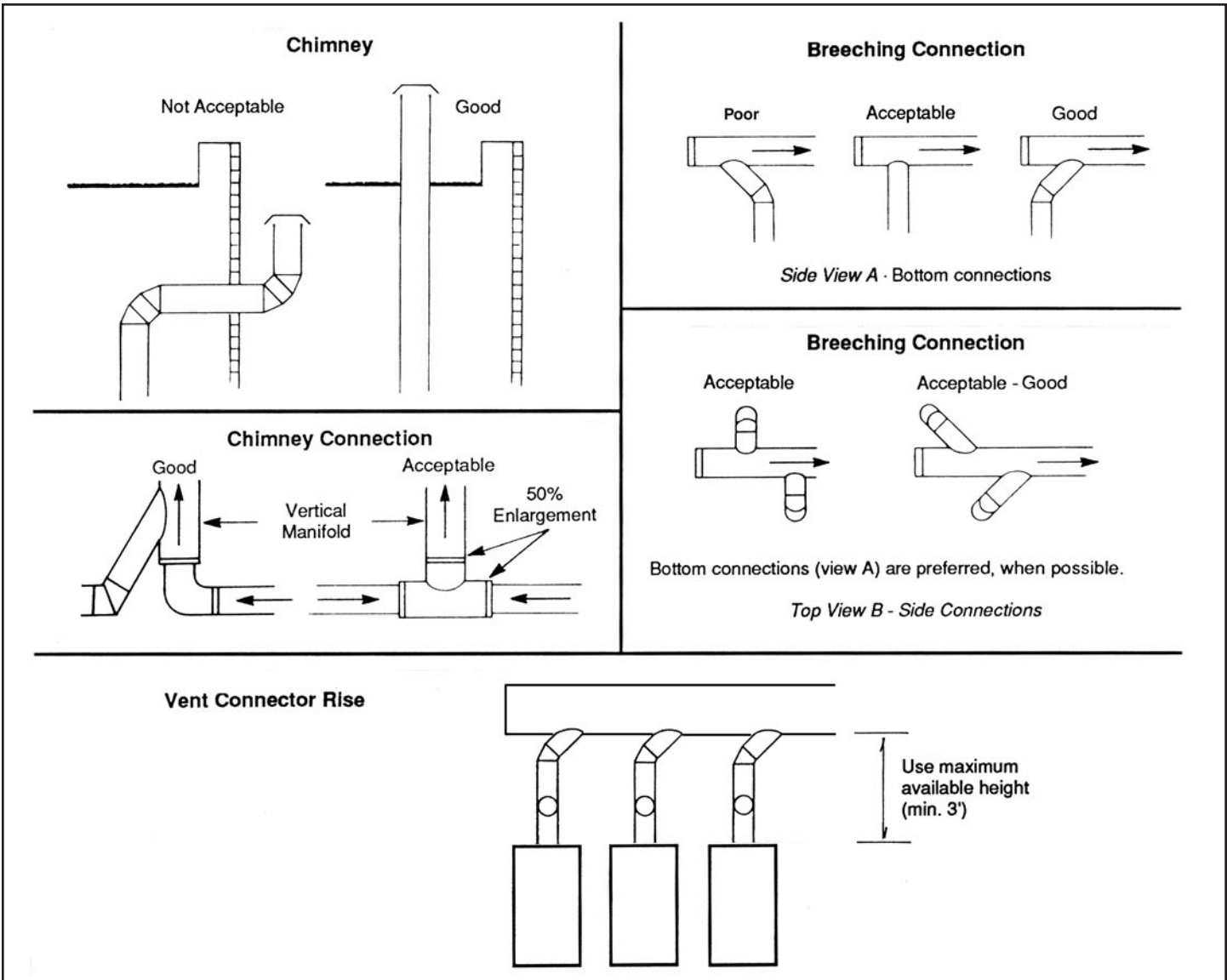

Figure 13. Suggested venting system constructions

FUEL OIL PIPING

FUEL OIL STORAGE FACILITIES

Local codes usually govern the installation of fuel oil storage facilities. However, for areas where no rules have been established, the following information can provide assistance to the system designer.

Storage tank sizing

When calculating minimum fuel oil storage capacity, several variables must be considered. These include: maximum fuel consumption rate, storage space limitations, availability, distance from source of supply, and method of delivery (truck or railroad tank car). Large storage tanks, of course, cost more than smaller ones but the cost is not proportional (e.g., a 10,000 gal. tank does not cost twice as much as a 5,000 gal. tank). And larger tank capacity allows oil purchases usually at lower per gallon rates.

Generally, the storage tank should hold enough oil to sustain continuous operation for 10 days (plus an additional 10% margin to allow for suction stub clearance).

To determine the minimum storage requirement, proceed as follows:

- Refer to Table 1 to find the maximum hourly oil consumption (GPH) of the system being installed.
- Multiply the maximum hourly consumption by the probable maximum daily hours of operation to achieve maximum daily consumption.
- Multiply the maximum daily consumption by 10 (days) and add 10% to obtain the MINIMUM storage capacity.

Requirements for fuel oil storage tanks.

Data in this section is based on the use of steel storage tanks. Where no local codes apply, take the following data into consideration.

- Inside tanks are usually located in the lowest part of the building. When supply and return lines are piped through the top of the tank, spillage is minimized in the event of leaks.
- Unenclosed tanks should be at least 7 feet from any open flames or fires.
- Most fire codes prohibit unenclosed inside tanks exceeding 275 gallons each. Where multiple tanks are installed, the total storage capacity should not exceed 550 gallons unless vaulted.
- If inside tanks are properly enclosed, the maximum storage capacity can be increased to 5,000 gallons in non-fire-resistant buildings, and to 15,000 gallons in fire-resistant structures.

NOTE: An enclosure shall consist of walls constructed of 6" reinforced concrete or 8-inch thick masonry with the space between tank and walls filled with sand. If floor above has a load-bearing capacity of 150 lbs./sq. inch or greater and is constructed of fire-resistant material, 1 foot of sand fill over the tank is sufficient. If not, a 5-inch concrete slab, or equivalent, must be employed. An alternative method is to pour a 6-inch thick concrete enclosure directly over the tank (no air spaces).

- Underground tanks (Figure 14) are to be buried at least 2 feet below grade.
- Tanks buried beneath buildings ALWAYS require 4-inch reinforced concrete slab covers that extend 1 foot beyond tank in all directions.

- Fiberglass and/or double-walled tanks may be required. Check your local codes. Underground metal tanks should be painted with heavy asphaltum, rust-resistant paint or be of double walled construction (check local codes). **DO NOT** install tank in bed of cinders (cinders contain sulphur, which becomes corrosive when wet).

NOTE: Before installing underground tanks, check local surface water conditions. Where potential problems exist, concrete anchors should be provided. Follow per local and national codes.

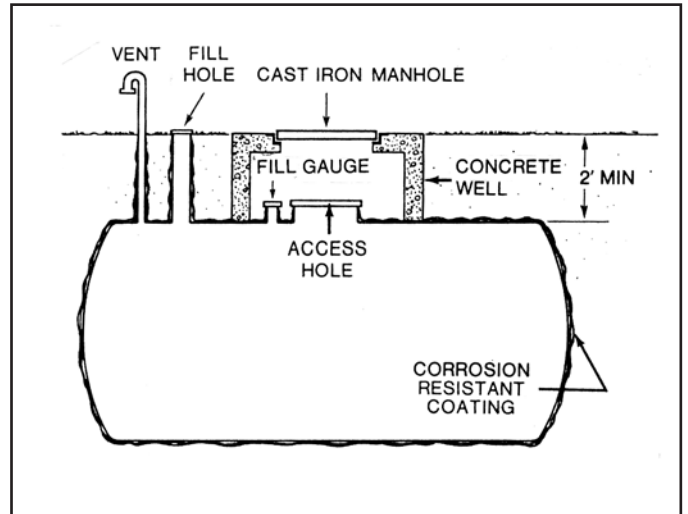

Figure 14. Typical example of properly installed underground fuel tank

FUEL OIL DELIVERY SYSTEMS FOR SINGLE FUEL BURNERS

General

Three methods for delivering oil to the individual burners are described herein. These methods are chosen to provide tempered, filtered and air-free oil to the individual burners. Consistent oil quality will optimize burner operation over longer periods.

There are variations to the methods described herein which, if applied properly, will result in acceptable operation. These methods are for reference only. Local codes vary. It is important to check all codes for compliance.

Information herein has been compiled using data from industry sources, including companies such as Mitco, Webster, Suntec and Tuthill. For additional information on these products, contact the representative in your area.

MFG data and safety codes vary with regard to maximum fuel unit inlet pressure. Pay particular attention to the gravity oil head. Be sure to add oil pressure reducing valves in the event that codes or MFG data will be exceeded. 5 psi is equivalent to approximately 12 feet in height. (See "H" dimension.)

Storage tank above burners (Figure 15)

A simple one pipe connection from the supply tank to each burner helps to eliminate air in the oil line and tempers the oil in the pipe as it travels slowly to the burners.

This method maintains consistent fuel oil quality to the individual burners and therefore decreases the frequency of maintenance and service. When a component breakdown occurs in a burner or in the supply system, the trouble is easily found and service is restored quickly.

Storage tank below burners and gravity tank above burners (Figure 16)

Oil is automatically and constantly maintained in the supply tank at a level sufficient to meet all burner needs. As oil is used, the pressure drop is sensed by a pre-set automatic pressure switch, which signals the booster pump to restore proper level. There is no practical limit on the height or distance that the motorized pump can deliver oil to the supply tank.

The great advantage of the booster pump along with a gravity tank is that it accomplishes its purpose in the most simple and direct manner. This results in the most economical installation, with the shortest possible runs of pipe and wire. It also enables the installer to adapt with ease to almost any building configuration. A simple one pipe connection to each burner helps eliminate air in oil line with constant flow of fuel and tempers the oil.

Simplicity of operation of the individual burner decreases the chances that service will be needed. When a component breakdown occurs in a burner or in the supply system, the trouble is easily found and service is restored quickly.

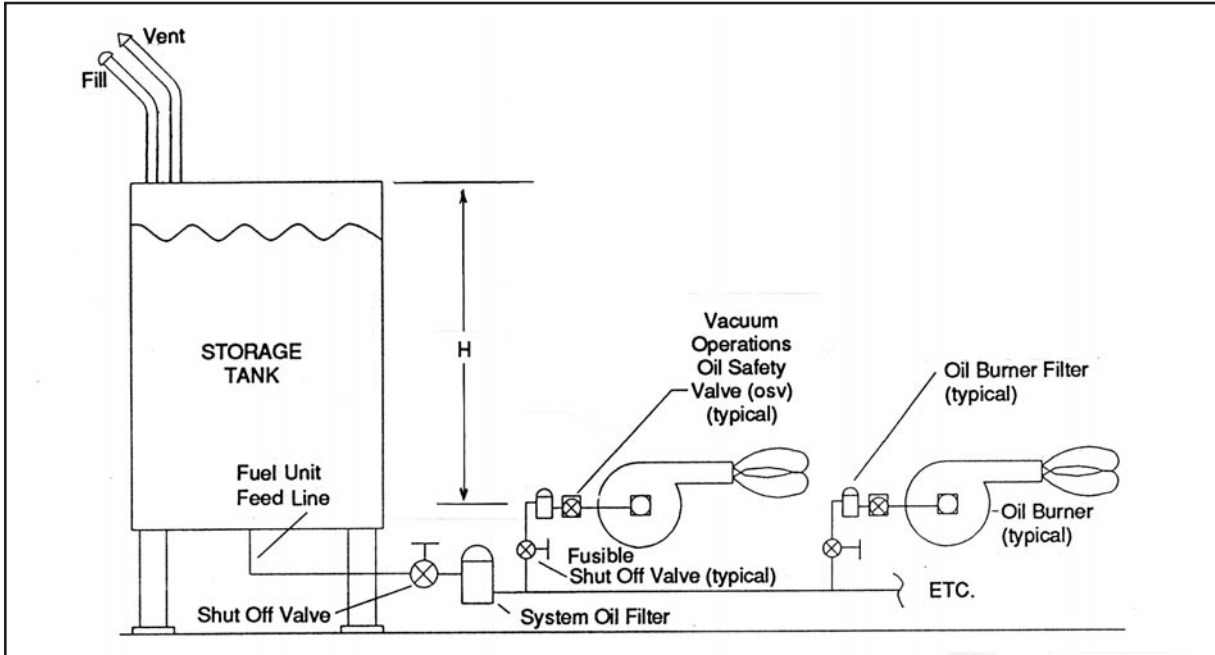

Figure 15. Storage tank above burners

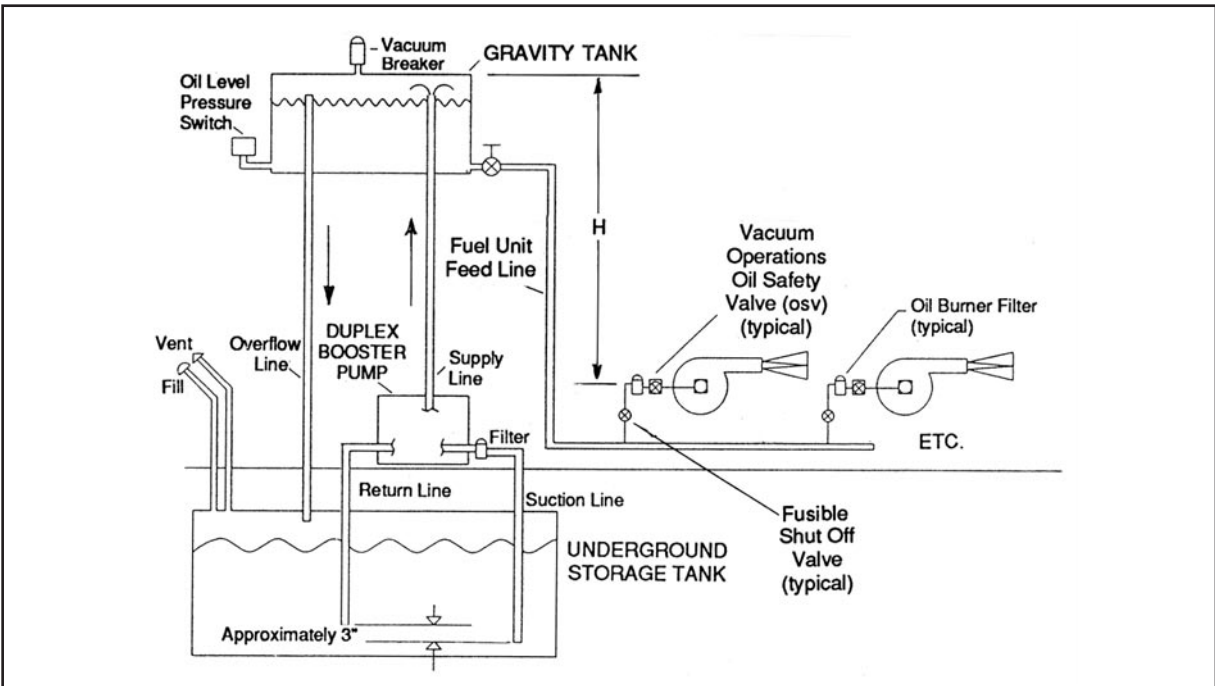

Figure 16. Storage tank below burners

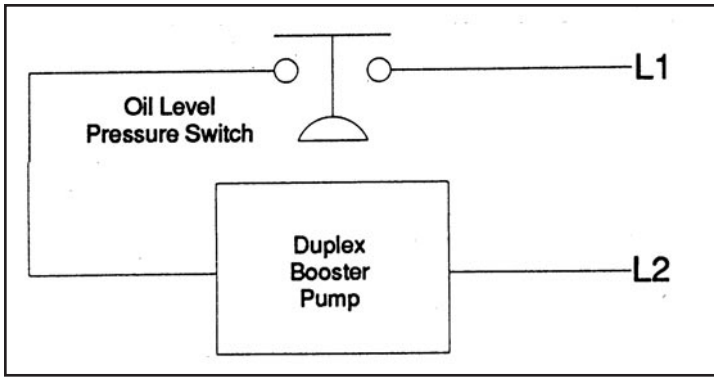

Figure 17. Wiring diagram for gravity feed booster- pump operation

Components usually required are a motorized booster pump of sufficient capacity, gravity tank and mounting hardware, automatic oil level pressure switch, vacuum breaker and necessary check valves and fittings. Additional information can be obtained from Mitco Manufacturing, Hicksville, New York.

Duplex booster pumps are desirable to provide standby capability, in the event of booster pump failure.

Sizing booster pump

To determine the correct size of a booster pump:

- Using Table 1, find maximum total firing rate of the boiler system being installed.
- Find the vertical and horizontal dimensions of the booster pump's suction line.
- Make sure the suction line lift and length are with capabilities of typical booster pumps. Refer to Table 5. (This data is based on Suntec models BH-1030M at 30 GPH, and BH-1050M at 50 GPH or equivalent.)

NOTE: If lift is excessive (max. 6" Hg one stage, 15" Hg two stage), contact pump manufacturer with exact requirements. If total length is too long, increase suction line diameter.

- Using Table 6, find correct supply line size.

Table 5. Maximum booster pump suction line length (1)

Vertical Lift (2)	Maximum Total Suction Line Lengths (3) 1/2" O.D. copper tubing (4)	
	Firing Rates up to 30 GPH (5)	Firing Rates up to 50 GPH (6)
0 - 7'	100'	63'
8 - 10'	80'	53'
11 - 13'	63'	41'
14 - 15'	52'	34'

- Defined as the connection distance between storage tank and inlet of booster pump.
- Height of booster pump inlet above bottom of storage tank. If higher lift is needed, contact booster pump manufacturer with exact requirements.
- Total suction length equals vertical lift plus horizontal distance between suction line connection at storage tank and inlet of booster pump.
- 5/8" tubing allows maximum horizontal distance between supply tank outlet and booster pump inlet to be safely increased by 250%.
- Maximum fuel oil consumption rate with Suntec BH-1030M pump.
- Maximum fuel oil consumption rate with Suntec BH-1050M pump.
- Supply line is defined as the connection between the outlet of the booster pump and the inlet of the supply tank.
- Total supply line length equals vertical lift plus horizontal distance between booster pump outlet and supply tank inlet.
- Boiler feed line is defined as the connection between the gravity feed tank and the furthest burner.

Table 6. Supply line sizes for high-volume fuel oil delivery systems (7)

Firing Rate	Maximum Total Supply Line Length (8)		
Up to 30 GPH (5)	300'	800'	2500'
Up to 50 GPH (6)	175'	350'	1500'
Supply Line Size	1/2" O.D. tube	1/2" pipe	3/4" pipe

Table 7. Boiler feed line sizes (9)

Total Length Maximum	Firing Rates up to 30 GPH (5)	Firing Rates up to 50 GPH (6)
25'	1/2" O.D. tube	1/2" O.D. tube
75'	1/2" pipe	1/2" pipe
200'	3/4" pipe	3/4" pipe

Table 8. Line Length for Two-Stage Fuel Unit

Two Pipe Lift Ht.	1/2" O.D. Tubing		5/8" O.D. Tubing	
	A	B	A	B
1'	118	99	328	276
2'	113	95	313	263
3'	107	90	298	250
4'	102	86	283	237
5'	96	81	268	225
6'	91	76	253	212
7'	86	72	238	200
8'	80	67	222	187
9'	75	61	207	174
10'	69	58	192	161
11'	64	54	177	148
12'	58	49	162	136
13'	53	44	147	123
14'	47	40	131	110
15'	42	35	116	98

A = B82 Series Suntec Pump 63 GPH gear capacity.
B = B89 Series Suntec Pump 75 GPH gear capacity.

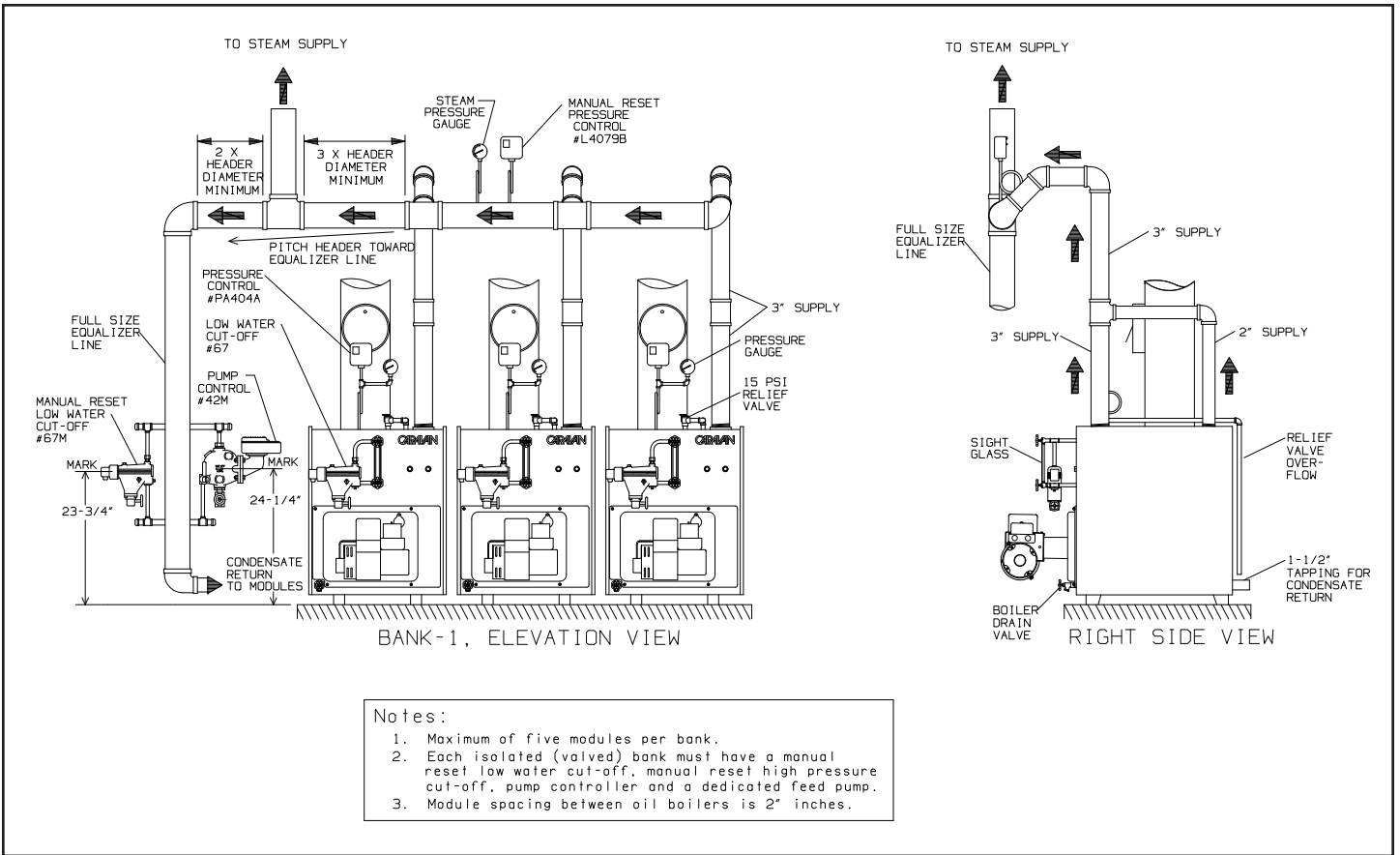

Figure 7. Typical Three Module Bank (LDZO-1300-3-7)

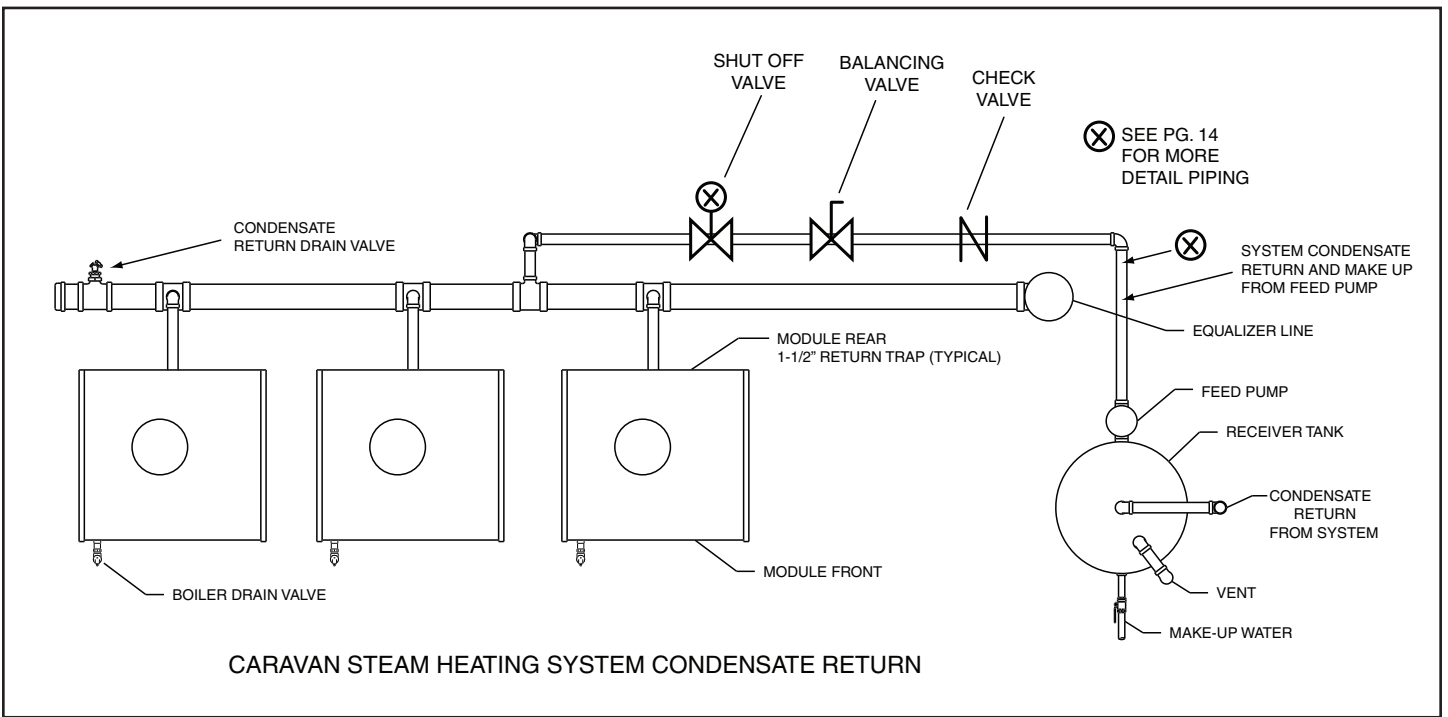

Figure 7a.

STEAM SUPPLY AND RETURN PIPING

Modular steam boilers must be piped in a way that provides nearly equal steam pressure at all modules. Supply and return pipes and fittings should be identical on each module. The pressure drop in the supply header, between the connection to the building and the supply tapping on each module must be kept to a minimum. When installed properly, this will result in minimal variance in water levels between modules. Figure 8 shows the take off to the system after the last module and before the equalizer/drain line. Header size shown on this page (Table 8) is based on this

Table 8: Modular steam boiler plant header pipe sizing

No. of Modules	Capacity Steam EDR	Header Pipe Sizes	
		Supply	Return
2	1946	3"	1.5"
2 or 3	2311	4"	2.0"
3 or 4	3287	5"	2.0"
4	4379	6"	2.0"

Maximum 5 modules per bank.

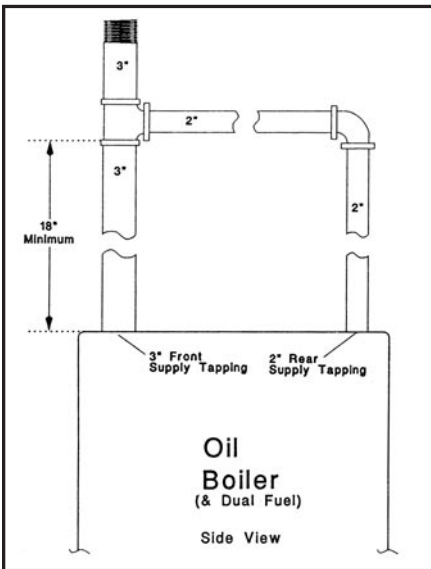

Figure 10: Steam supply header at oil modules

pipng arrangement. Figure 9 shows the piping arrangement between the module and header connections. In this area, try to keep the number of elbows to a minimum (maximum 3). It is important to note that a pressure difference of as little as one ounce (1/16 PSI) between modules will result in a water level difference of almost 2 inches.

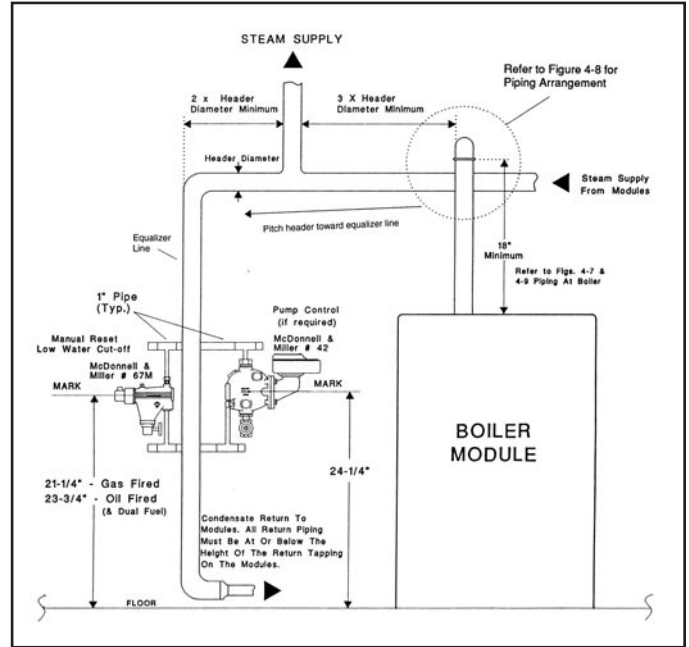

Figure 8: Piping details

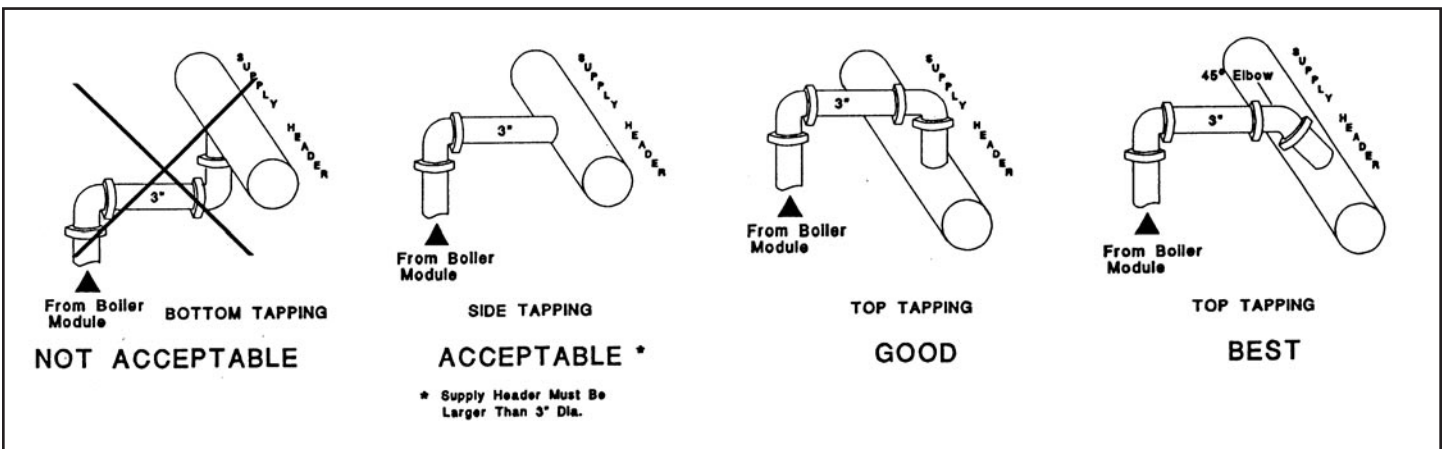

Figure 9: Steam supply header piping

INSTALLATION AND PIPING RECOMMENDATIONS

When one or more steam boilers are replaced with a new Caravan modular boiler system, there are certain conditions that must be considered.

1. All modules must be set on a level surface, and individually leveled.
2. Modules should be mounted on a 3" high level concrete base.
3. 2" minimum clearance between modules.
4. 2" rear supply tap on module must be piped into the 3" front supply pipe as shown in Fig. 10 on page 10 to minimize pressure drop, no more than three 90° elbows should be installed between the module supply tapping and steam header (See figure 9, page 10)
5. All banks of modules must have an equalizer/drain line from the supply header to the return header. This equalizer/drain should be located at the end of the header that the system steam supply is taken from. The equalizer/drain should be the same size as the supply header (see figure 8, page 10). The supply & return header for each bank should be sized according to Table 8, page 10.
6. To prevent accumulation of condensate, steam headers should be pitched down in the direction of steam flow and toward the equalizer/drain with no reduction in size. Module connections must be on the side of the header (horizontal) or at any angle between the side and top of header, never between the side and bottom. To prevent condensate in the header from re-entering the boiler supply pipe, side connections must enter a header that is at least one size larger than the boiler supply connections. Top or 45° top-angle connections are preferred and can enter a header of the same size or larger. See Figure 9. The supply header for each module should be sized according to Figure 10, page 10.
7. The supply connection between the building steam main and the module steam header should be located between the last boiler on the header and the equalizer/drain. Connection must be at least 2 header diameters from the last module (see Figure 8, Page 10).
8. Piping should provide a means for both surface and bottom blow-down and flushing sediment from the system for clean, safe and efficient operation (see Figure Fig. 7 page 9).
9. The use of a pump control is recommended to regulate the water level in a bank of boilers and prevent the bank from operating with an unsafe low water condition. For protection of banks with 2 to 5 modules, the control should be located on the equalizer line. All applications require a low water cut-off on each module and one cut off for each bank.
10. Supply and/or return shut-off valves on individual modules are not recommended. However, if valves on individual modules are unavoidable, additional safety controls are required on each module. Full-port valves should be used to minimize pressure drop and should be the same diameter as the pipe.
11. Impurities and oxygen in fresh water cause scaling and leave deposits in the boiler and surrounding pipes. This leads to inefficient operation and other system problems. The older the system, the greater the probable accumulation of scale. Therefore, it is necessary to check the piping for blockage or restriction and clean or replace the piping as required. Applications such as process systems can result in excessive introduction of fresh water into a steam boiler. This will damage the boilers and void any warranty. Caravan modular boiler systems are not recommended for applications involving the use or discharge of raw steam or condensate. In all cases, boiler water should be tested periodically to determine if conditioning treatment is needed. Consult a local boiler water treatment expert.

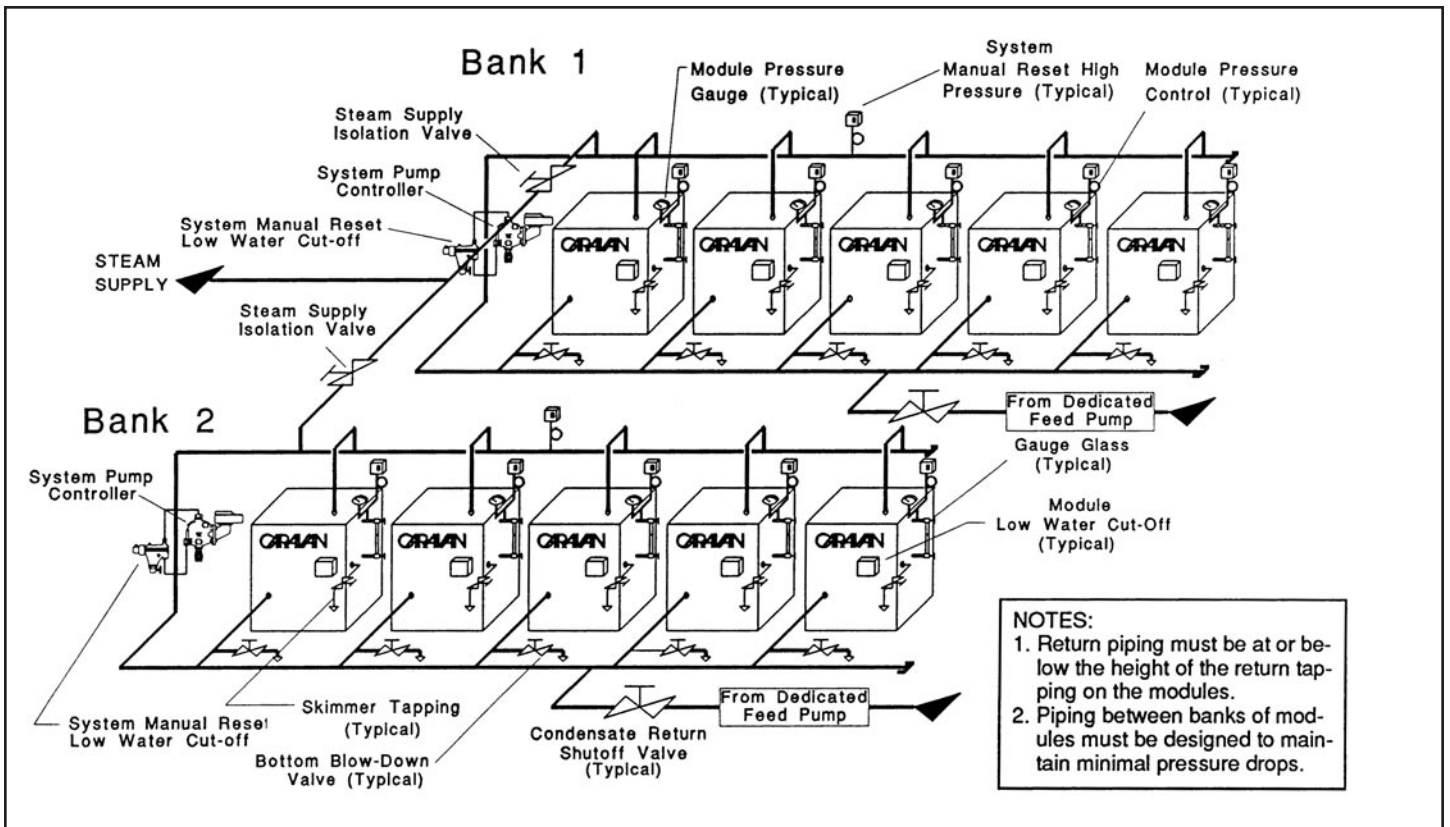

Figure 11: Steam modules, isolated banks (Note: For detail piping refer to pages 8 & 9)

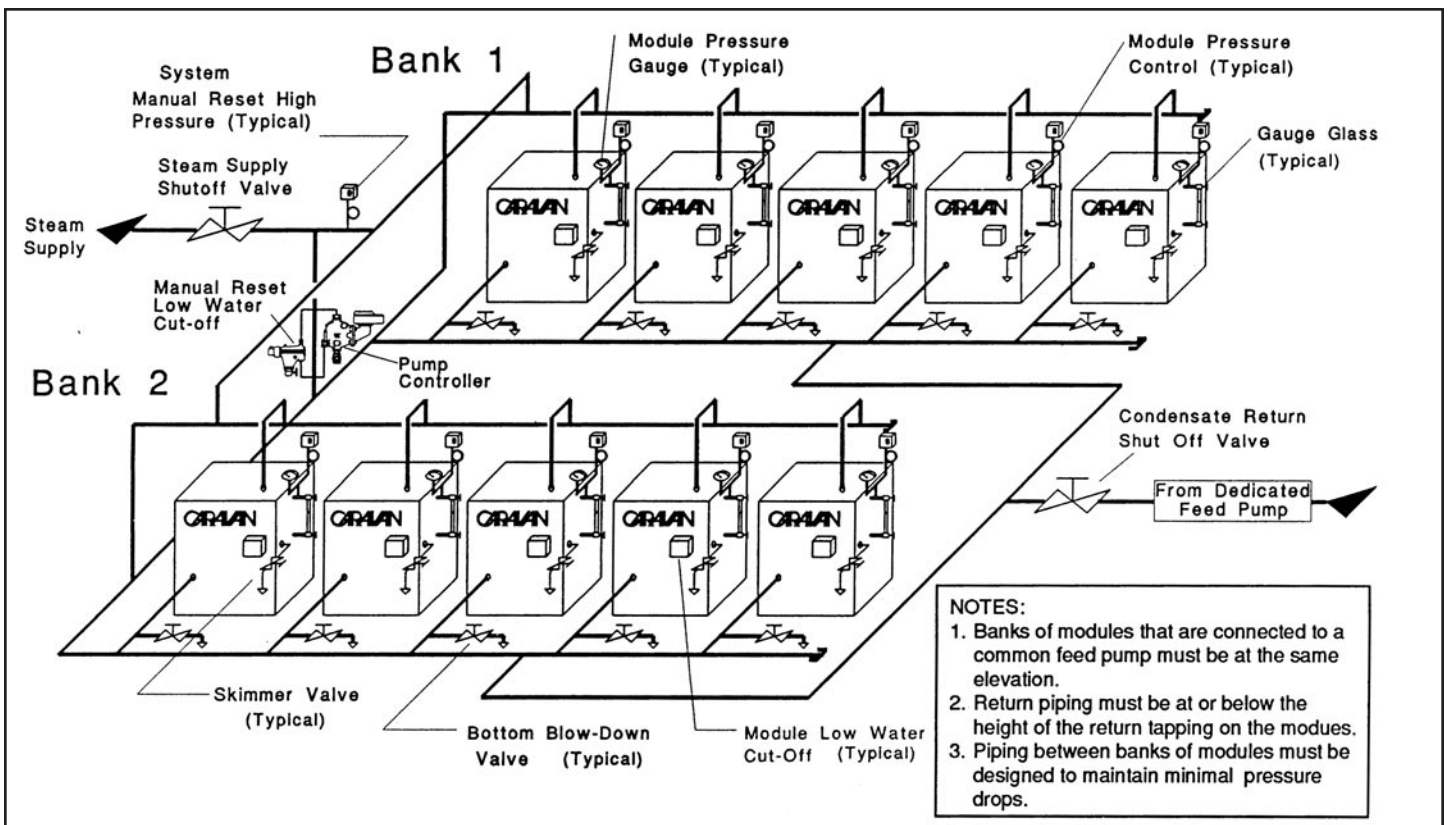

Figure 12: Steam modules, integrated banks (Note: For detail piping refer to pages 8 & 9)

12. Caravan modular boiler systems are often used as a replacement for old, large, inefficient boilers. Compared with older boilers, modern steam boilers have a relatively small water volume in the operating range. The result can be that a normal volume of condensate return water could create high water levels in the new modules. In most systems, the use of a combination feed-pump and receiver will prevent flooding. The recommended storage capacity for the receiver is shown in Table 9. This table is based on condensate returned to the receiver within twenty minutes of start-up. If the time required for returning condensate is greater, a larger receiver would be needed. Check with the feed pump manufacturer for the correct size. The feed-pump/receiver is used to store condensate returned from the system, provide feed-water to the boilers, as regulated by the pump control and add makeup water to the system.

A balancing valve **MUST** be provided on the feed-pump discharge line. This valve is used to adjust water volume to prevent feed-water from entering the boilers too quickly, which can cause water levels to “bounce”. The pump discharge pressure must be slightly higher than the steam operating pressure. A rate of 1 GPM per module is more than sufficient to feed a steam Caravan system (see Table 9). The feed pump is activated by a pump control mounted on the equalizer drain line, (see Figure 8, page 10). When the boiler water level drops, the pump control energizes the feed-water pump, transferring feed-water from the receiver to the bank of modules. On systems with more than one bank of boilers that are isolated (valved), each bank must have a dedicated feed-pump with a dedicated power supply, (see Figure 11, page 12). This will prevent the operation of one bank of boilers from interfering with another.

During operation, condensate from the heating system is constantly being returned to the receiver. It is natural that some steam / condensate will be lost through venting and small, undetected leaks in the system. When the receiver water level drops below a predetermined low level, a float mechanism allows make-up (fresh) water to enter the receiver and replace any water lost in the system. However, if this is occurring frequently, the system should be checked for leaks. The use of a water meter in the make-up line is recommended.

Certain local codes may require a Hartford Loop. However, the use of a Hartford Loop is otherwise not recommended when using a feed-pump. Consult your local authorities.

WARNING: The description in this manual is for a boiler feed-pump only. Do not use a “condensate pump” in place of a feed-pump on a Caravan system. Unlike a feed-pump, a condensate pump will pump water into the boilers regardless of the boiler water level. Some systems may require the use of condensate return pumps in distant parts of the system. These condensate pumps must discharge into the boiler feed-pump/receiver, not into the boilers.

13. All equipment such as steam traps and air vents in the steam heating system should be checked for proper operation and replaced or repaired as needed. All piping should be checked for proper pitch.

14. It is good practice to re-pack and/or tighten the packing nuts on all valves in the system.

Definitions of terms

- **Make-up water:** Fresh water introduced into the system to compensate for evaporation, leaks, blow-down and other use of steam or condensate.
- **Condensate water:** Water that has been condensed from steam in the system.
- **Feed-water:** Any mixture water, both condensate and make-up, that enters the boilers to maintain water level.
- **Header:** The pitched horizontal pipe connecting the modules where steam or condensate flows to or from a bank of modules.

Table 9: Boiler feed pump and receiver sizing

No. of Modules	Gas		Oil	
	Min. GPM	Net Storage	Min. GPM	Net Storage
1	.65	13	.75	15
2	1.30	26	1.50	30
3	1.95	39	2.25	45
4	2.60	52	3.00	60
5	3.25	65	3.75	75
6*	3.90	78	4.50	90
7*	4.55	91	5.25	105
8*	5.20	104	6.00	120
9*	5.85	117	6.75	135
10*	6.50	130	7.50	150
11*	7.15	143	8.25	165
12*	7.80	156	9.00	180
13*	8.45	169	9.75	195
14*	9.10	182	10.50	210
15*	9.75	195	11.25	225

* Maximum 5 modules per bank.

On systems with more than one bank of boilers, each bank must have a dedicated feed-pump with its own power supply. This will prevent the operation of the one bank of boilers from interfering with another.

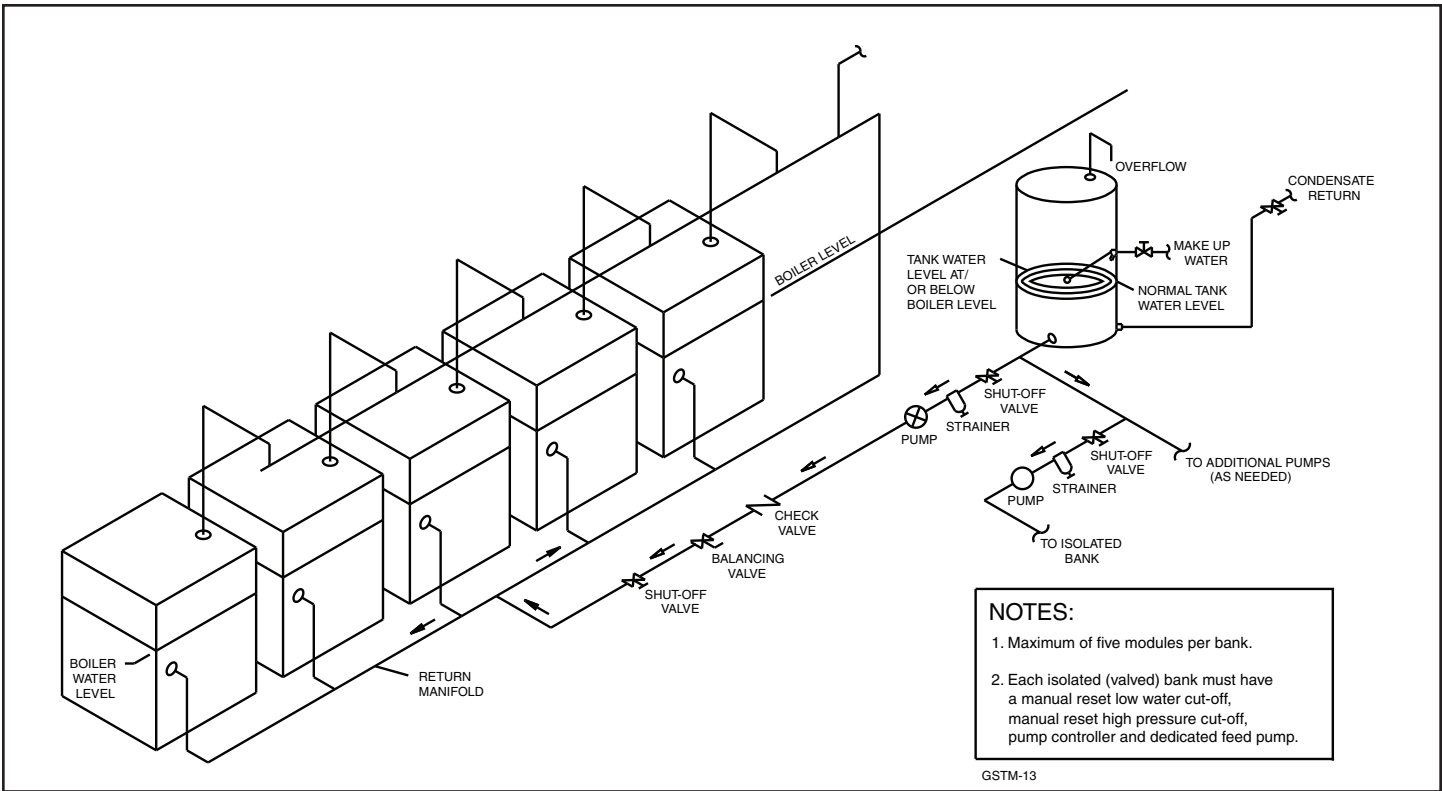

Figure 13: Installation with receiver tank water level at or below modules normal water levels

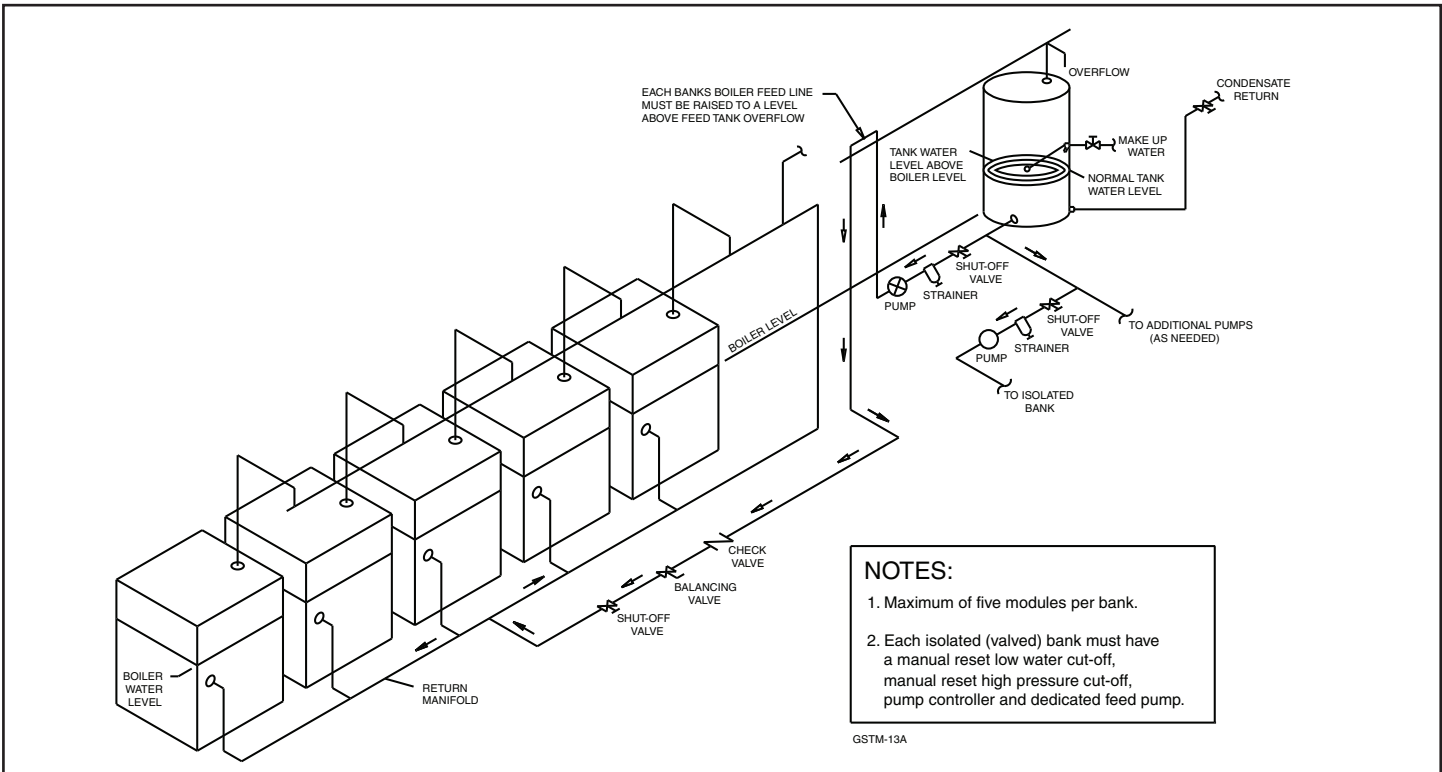

Figure 13A: Installation with receiver tank water level above modules normal water levels

MODULAR STEAM WITH SPACE TEMPERATURE CONTROL WIRING DIAGRAM

Sequence of operation

When the building thermostat calls for heat, contacts (RC) of the R8285B control closes. This energizes the coils of R1 and R2 relays. With these contacts closed, all the modules are energized to fire. This will bring the system pressure up quickly. The P404A pressure controls on each module (not shown in diagram, see figure. 16) are set to

the pressure required to heat the building. This will stage the numbers of modules firing to meet the demands of the building load. The required modules will continue to fire until the thermostat is satisfied.

There are several manufacturers that provide more sophisticated controls for modular steam systems.

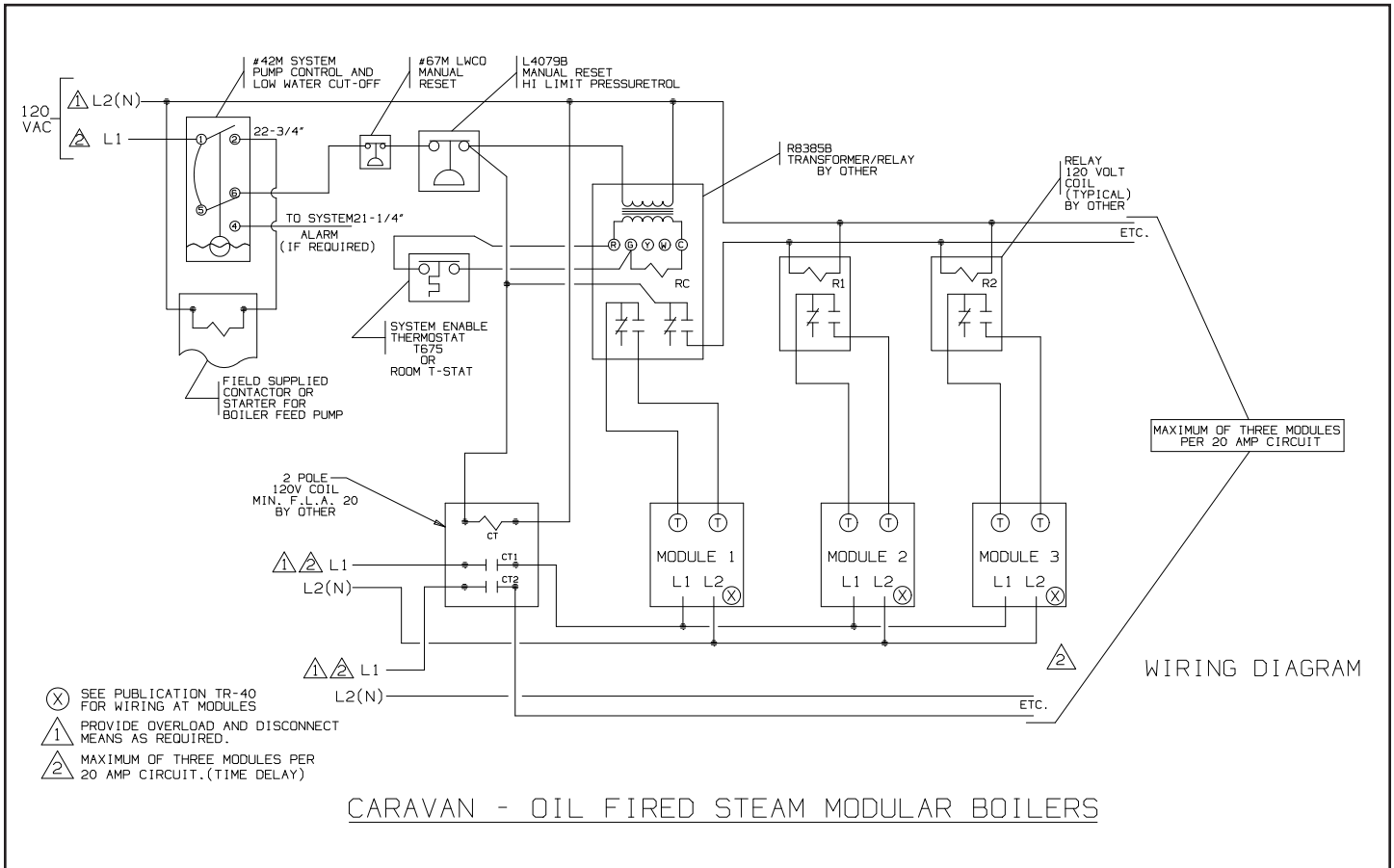
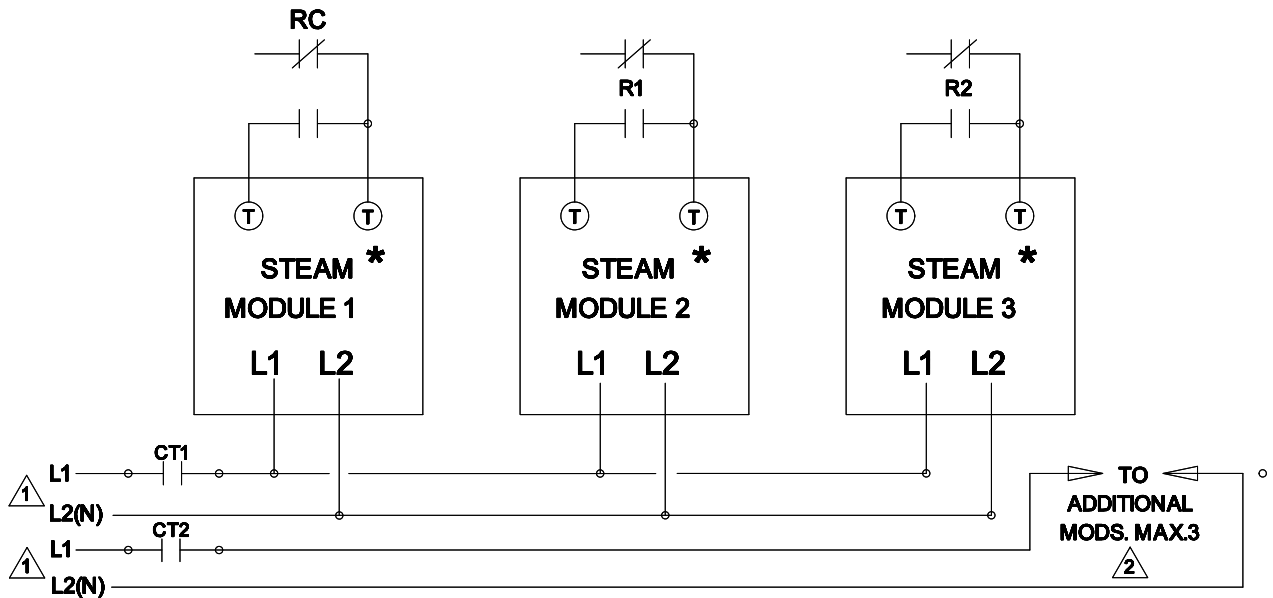
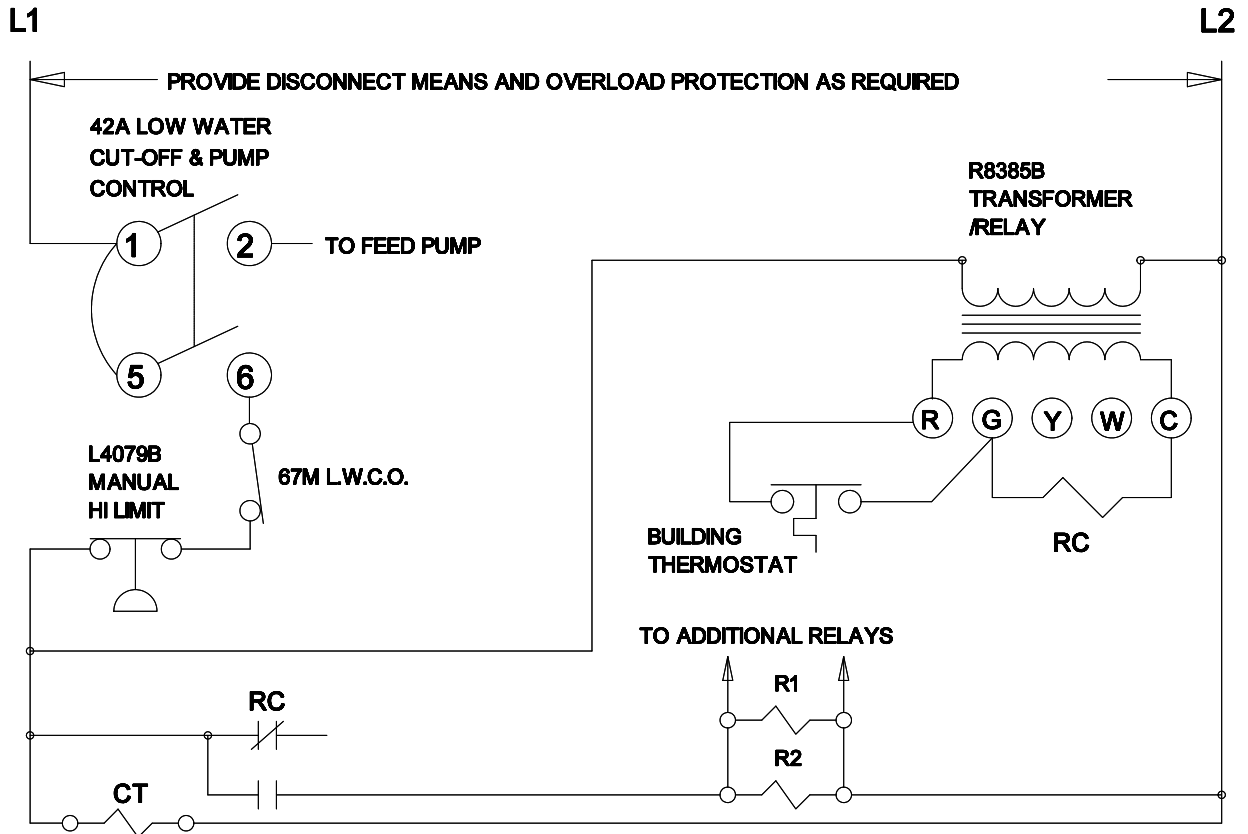

Figure 14: Space temperature control wiring diagram

MODULAR STEAM WITH SPACE TEMPERATURE CONTROL LADDER DIAGRAM



* - SEE WIRING AT MODULE ON PAGE 16 FOR CONNECTIONS

1 PROVIDE OVERLOAD AND DISCONNECT MEANS AS REQUIRED.

2 MAXIMUM OF THREE MODULES PER 20 AMP. CIRCUIT.

Figure 15: Space temperature control ladder diagram

WIRING FOR PACKAGED STEAM BOILER EQUIPPED WITH Mc DONNELL NO. 67 L.W.C.O.

High-Pressure Limit
 Recommended setting 0.5 PSI
 Differential 5 PSI

Low Limit (tankless model only)
 recommended setting 160°F

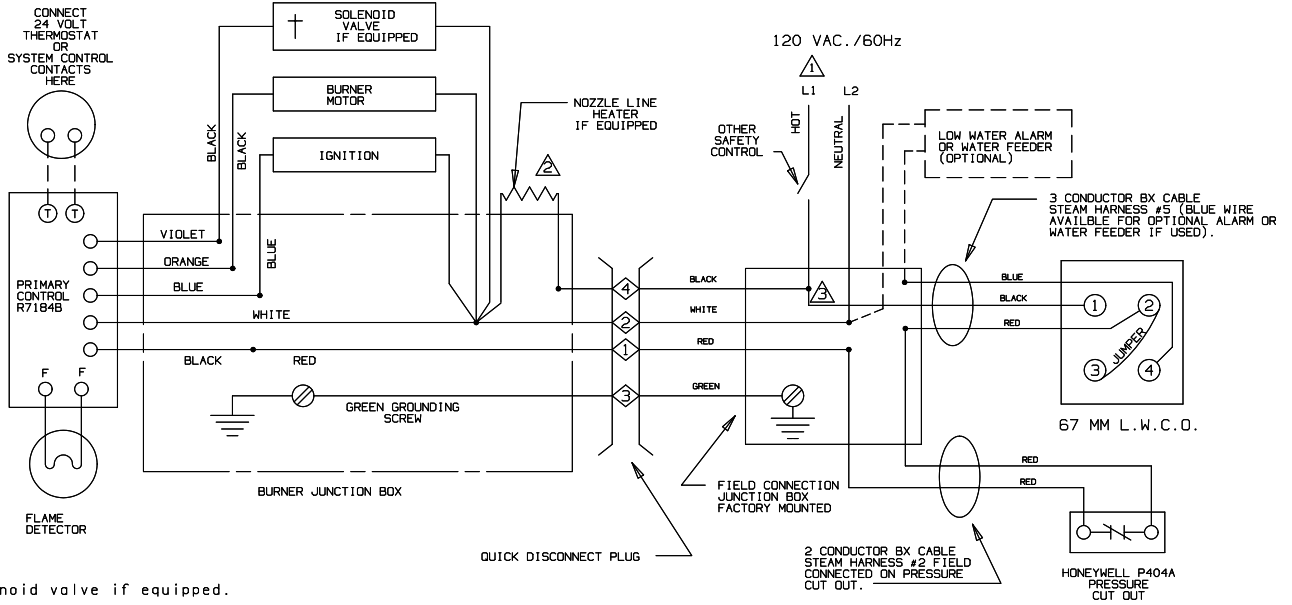

† Solenoid valve if equipped.

• Splice

○ Terminal

⚠ Overload protection and disconnect switch must be provided as required by local codes.

⚡ Nozzle line heater, if equipped.

⚡ On burners without nozzle line heater, field connect hot line to single black wire from 3 conductor box cable in 4 x 4 junction box.

Figure 16: Wiring at module

CARAVAN SYSTEM RATING PLATE

System rating plate format for Caravan modular boiler system.
System rating plates are available upon request using the form on the back cover.

Slant/Fin CORP. GREENVALE, NEW YORK 11548

CARAVAN
OIL FIRED CAST IRON BOILER SYSTEM
CARAVAN SYSTEM SERIAL NO.:



CARAVAN MODEL NO.

CONSISTING OF _____ MODEL _____ BOILER MODULES
INDIVIDUAL BOILER MODULE SERIAL NUMBERS:

MODEL NO.	CARAVAN SYSTEM	INDIVIDUAL BOILER MODULE
AHRI BURNER CAPACITY LIGHT OIL GALS./HR.:		
AHRI GROSS OUTPUT BTU/HR.:		
D.O.E. CAPACITY BTU/HR.:		
NET AHRI WATER BTU/HR.:		
NET AHRI STEAM BTU/HR.:		
NET AHRI STEAM SQ. FT.:		

SAMPLE

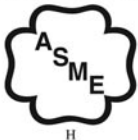

**CERTIFIED BY SLANT/FIN CORP.
MAXIMUM WORKING PRESSURE**

SYSTEM	INDIVIDUAL BOILER MODULE
MAWP, WATER <input type="text"/> PSI	MAWP, WATER <input type="text"/> PSI
MAWP, STEAM <input type="text"/> PSI	MAWP, STEAM <input type="text"/> PSI
MAXIMUM WATER TEMP. _____ F	MAXIMUM WATER TEMP. _____ F
TOTAL SYSTEM MINIMUM RELIEF VALVE CAPACITY <input type="text"/> LBS./HR. SEE INDIVIDUAL BOILER MODULE CAPACITY	MINIMUM RELIEF VALVE CAPACITY <input type="text"/> LBS./HR. FOR INDIVIDUAL BOILER MODULES

43-0312 .jhw



REQUEST FOR CARAVAN SYSTEM RATING PLATE

Each individual Caravan module is shipped with a rating plate bearing the model, serial number, capacities and certifications for that module. A modular boiler system is a single boiler. To meet local requirements, a system rating plate will be issued by Slant/Fin upon request. Just provide the information indicated on this page.

Slant/Fin Tech Service	FAX THIS REQUEST TO: 516-484-6958
	PHONE: 516-484-2600

Requested by: _____

Phone: _____
Required

Mail to: _____

Phone: _____
Required

NOTE:

INDICATE ACCURATELY
Some model numbers are similar, such as GGT-600 and GGT-600E etc.
PLEASE USE CARE TO MAKE SURE THE PROPER SYSTEM MODEL IS INDICATED COMPLETE WITH LETTER SUFFIX.
BE ACCURATE!
INCLUDE ALL LETTERS AND ZEROS, ENTER ALL INFORMATION ASKED FOR!
USE A SEPARATE FORM FOR EACH SYSTEM

Type of System:

- | | |
|--------------------------------|--------------------------------------|
| <input type="checkbox"/> Gas | <input type="checkbox"/> Natural Gas |
| <input type="checkbox"/> Oil | <input type="checkbox"/> Propane |
| <input type="checkbox"/> Water | <input type="checkbox"/> Steam |

INDICATE SYSTEM MODEL NUMBER BELOW:

INDICATE SERIAL NUMBERS OF INDIVIDUAL MODULES (Please write legibly)

_____	_____
_____	_____
_____	_____
_____	_____
_____	_____

DO NOT WRITE BELOW THIS LINE • FOR SLANT/FIN USE ONLY

System serial number assigned _____ Done by _____



SLANT/FIN CORPORATION, Greenvale, N.Y. 11548 • Phone: (516) 484-2600
FAX: (516) 484-5921 • Canada: Slant/Fin LTD/LTEE, Mississauga, Ontario

www.slantfin.com