



# COMMERCIAL FIN-TUBE ENCLOSURES MODELS J, JR, R, RR, EM, AND F

## INSTALLATION INSTRUCTIONS

### GENERAL INFORMATION

Use the following table for recommended numbers of bracket-hanger assemblies for each piece of enclosure.

Element	J-SERIES			R-SERIES			TBG-SERIES		
	2	3	4	2	3	4	2	3	4
C-340	2-5 ft.	6-8 ft.	—	2-5 ft.	6-8 ft.	—	2-5 ft.	6-7 ft.	8 ft.
C-440	2-5 ft.	6-8 ft.	—	2-5 ft.	6-8 ft.	—	2-5 ft.	6-7 ft.	8 ft.
C-540	2-5 ft.	6-8 ft.	—	2-5 ft.	6-8 ft.	—	2-5 ft.	6-7 ft.	8 ft.
S-532	2-5 ft.	6-7 ft.	8 ft.	2-4 ft.	5-7 ft.	8 ft.	2-5 ft.	6-7 ft.	8 ft.
S-540	2-5 ft.	6-7 ft.	8 ft.	2-4 ft.	5-7 ft.	8 ft.	2-5 ft.	6-7 ft.	8 ft.
S-832	2-4 ft.	5-6 ft.	7-8 ft.	2-4 ft.	5-6 ft.	7-8 ft.	2-5 ft.	6 ft.	7-8 ft.

### Telescopic accessories

These accessories telescope up to 2" of total length dimension. Wall to wall dimension, figured at job site, is not effected.

### Joining Commercial Enclosures

1. J Series- use internal splice plate to join enclosures together. Internal Splice plate instructions are in the back of this manual. Generally, use of external splice plate is not required.
2. R, RR, JR and TBG Series- Use double slip joint to join enclosures. Joining strip for insertion in double slip joint included and packed with cover panels. Generally, use of external splice plate is not required.
3. EM and F Series- Use external splice plate to join enclosures.

### Damper

When specified, the damper is factory installed except the damper knob and rod assembly. See instructions in this manual for field installation.

### Accessories

JA-14 & JL illustrated: similar accessories available for other enclosures.

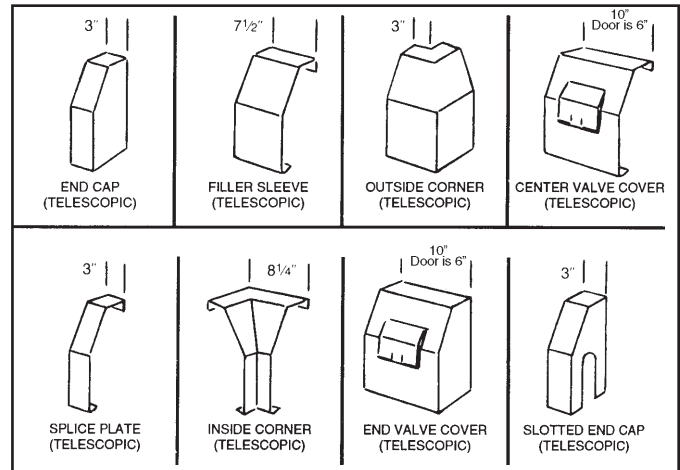

NOTE: When using valve covers, an additional bracket should be installed at the right or left end of the valve cover for additional support.

### SERIES J & R ENCLOSURES WITHOUT BACK PANEL

#### STEP 1:

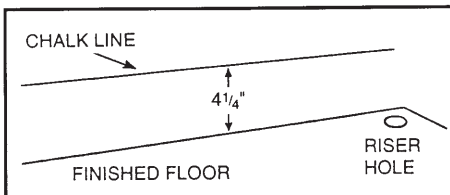

Mark chalk line.

#### STEP 2:

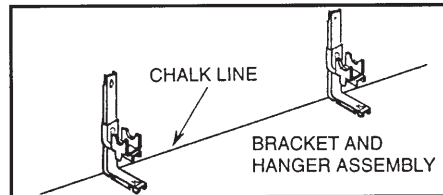

- a) Attach hanger to bracket with Sems screws furnished (1/4" x 20 x 1/4").
- b) Mount assembly to wall at chalk line.
- c) Align hanger for necessary pitch.

#### STEP 3:

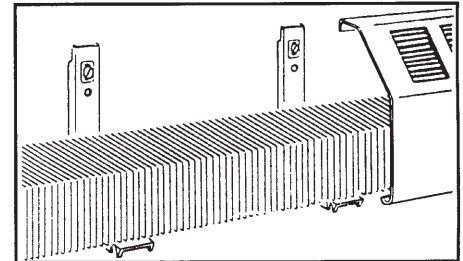

- a) Install elements, connect and test system
- b) Install cover by inserting the top lip between wall and bracket. Pull down and back until bottom lip snaps into slot on bracket.
- c) Follow through with accessories.

**SERIES J & R ENCLOSURES WITH BACK PANEL**

**STEP 1:**

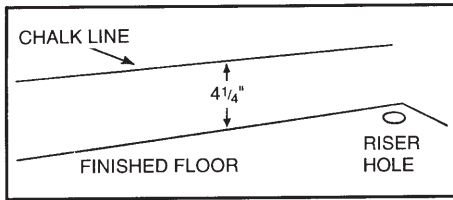

Mark chalk line, as above.

**STEP 2:**

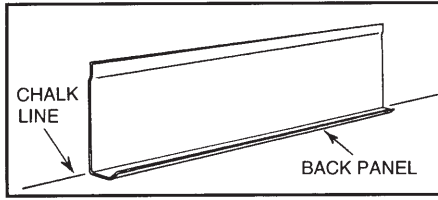

Install back panel at chalk line.

**STEP 3:**

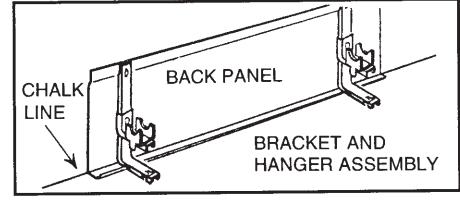

- a) Attach hanger to bracket with Sems screws furnished (1/4" x 20 x 1/4").
- b) Mount assembly to back panel.
- c) Align hanger for necessary pitch.

**STEP 4:**

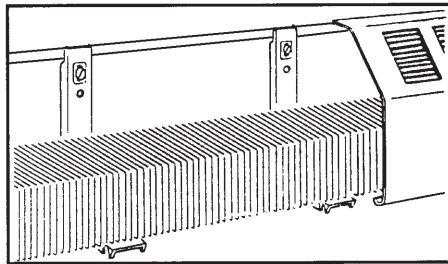

- a) Install elements, connect and test system.
- b) Insert top lip between wall and back panel. Pull down and back until bottom lip snaps into slot on bracket.
- c) Follow through with accessories.

**SERIES J & R ENCLOSURES WITH BOTTOM INLET GRILLE**

**STEP 1:**

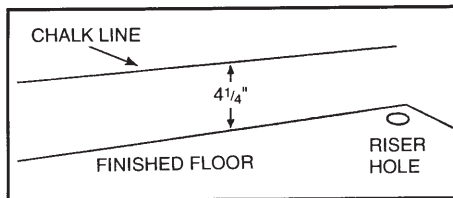

Mark chalk line.

**STEP 2:**

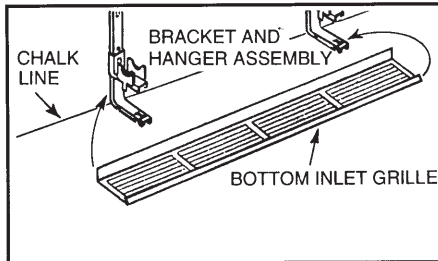

- a) Attach hanger to bracket with Sems screws furnished (1/4" x 20 x 1/4").
- b) Mount to wall at chalk line. Leave bottom screws loose for friction fit of back edge of bottom inlet grille.
- c) Install bottom inlet grille to bracket. Complete mounting of bracket to wall.
- d) Align hanger for necessary pitch.

**STEP 3:**

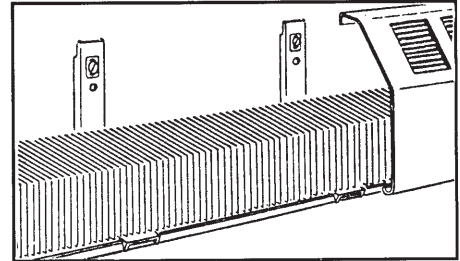

- a) Install elements, connect and test system.
- b) Snap on cover, insert top lip between wall and bracket. Pull down and back until bottom lip snaps into slot on bracket.
- c) Follow through with accessories.

**SERIES JR & RR ENCLOSURES WITH 4" TOP MOUNTING RAIL (BPT)**

**STEP 1:**

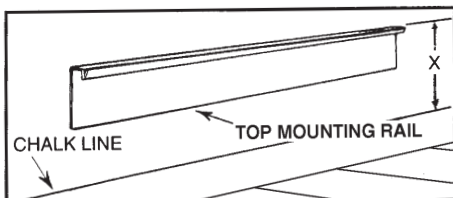

- a) Mark chalk line.
- b) Install top mounting rail above chalk line using the following dimensions: for enclosures with 1-tier of element 10", 1-tier of element 14", 2-tier 21" and 3-tier 28".

**STEP 2:**

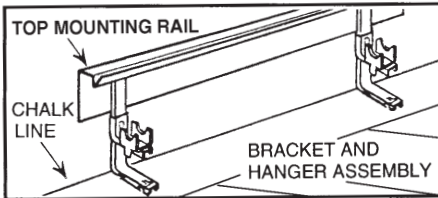

- a) Attach hanger to bracket with Sems screws furnished (1/4" x 20 x 1/4").
- b) Mount assembly to back panel.
- c) Align hanger for necessary pitch.

**STEP 3:**

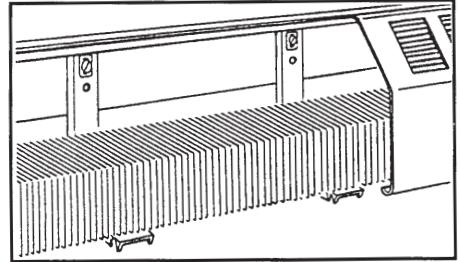

- a) Install elements, connect and test system
- b) Insert cover in the "V" channel in top mounting rail. Pull down and back until bottom lip snaps into slot on bracket.
- c) Follow through with accessories.

## DAMPERS

### DAMPER KNOB & LEAD SCREW ASSEMBLY INSTRUCTIONS

1. Screw LEAD SCREW into LEAD SCREW NUT about 10 turns clock wise in direction shown.
2. Line up LEAD SCREW with BUSHING hole by sliding DAMPER left or right.
3. Swing DAMPER toward COVER and guide LEAD SCREW through BUSHING hole until beginning of SCREW thread is against BUSHING and SCREW EXTENSION protrudes through front of COVER. Hold in place and proceed to step 4.
4. Place KNOB on to SCREW EXTENSION and line up allen head SET SCREW in KNOB with FLAT of SCREW EXTENSION and tighten set screw with an allen wrench.

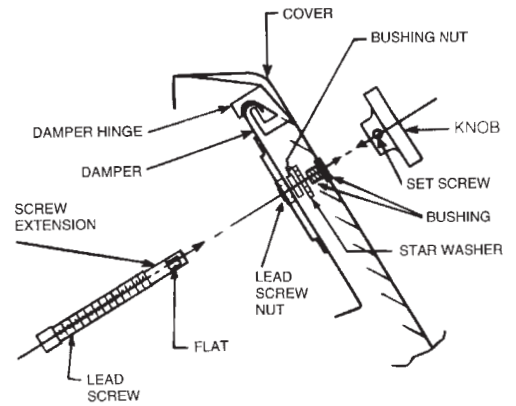

## SERIES EM, F AND BARE ELEMENT

### STEP 1:

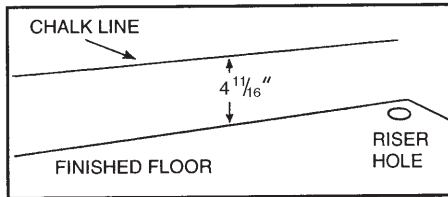

Mark chalk line.

### STEP 2:

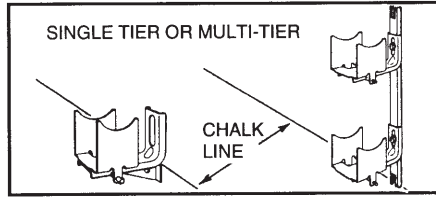

- a) Mount required hanger at chalk line.
- b) Align hanger for necessary pitch.

### STEP 3:

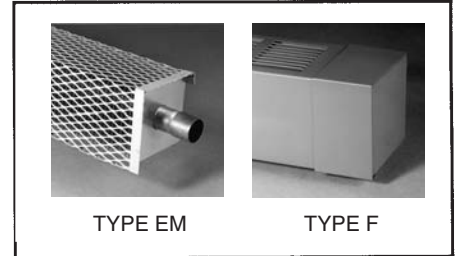

- a) Install elements, connect and test system
- b) Slip on cover, insert top flange of cover between wall and fins, cover rests on fins.

## ACCESSORIES

### FIT BOTH EM & F COVERS:

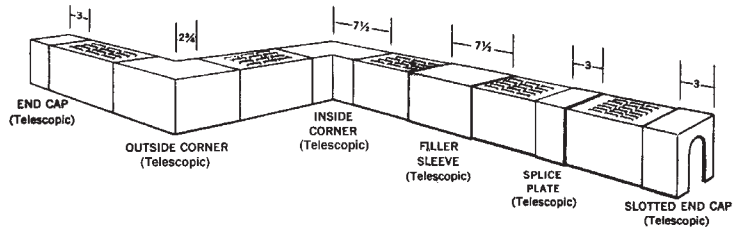

## TYPICAL ARRANGEMENTS OF ENCLOSURES FOR SERIES J OR R

### Enclosure same length as element.

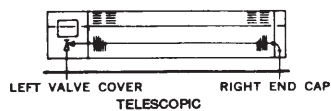
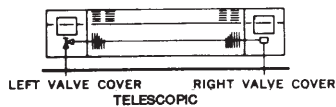

To allow adequate space for fittings, use enclosure one foot longer than element.



When room partition will be installed after enclosure.



When partition is installed later, remove filler sleeve and replace with 2 slotted end caps.

### Wall-to-wall installations.

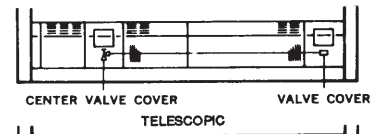
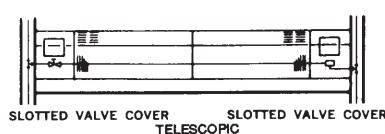

Filler sleeves, telescopic, 7 1/2" wide. For filling gaps at center or ends.

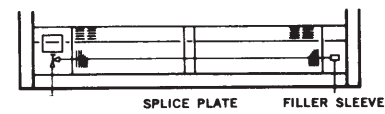

Splice plates, 3" wide, are used for narrower gaps.

## SERIES EM OR F

(Since cover rests on element, cover will be pitched on steam installations.)

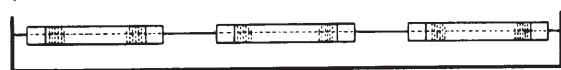

Individual covers with series-loop system, using slotted end caps.



Continuous Flat-top covers, using PC Hangers to support intermediate sections of cover.

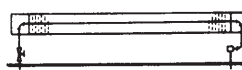

Individual type F cover with bottom steam connections.



Individual type F cover with hot-water monoflow system.

## INTERNAL SPLICE PLATE INSTALLATION INSTRUCTIONS

Cover sections may be tightly joined with internal splice plates for a neat, trim fit. They may be used instead of external splice plates.



### Step 1:

After installing support brackets on the wall at the desired height, place the cover over the brackets and snap in place.

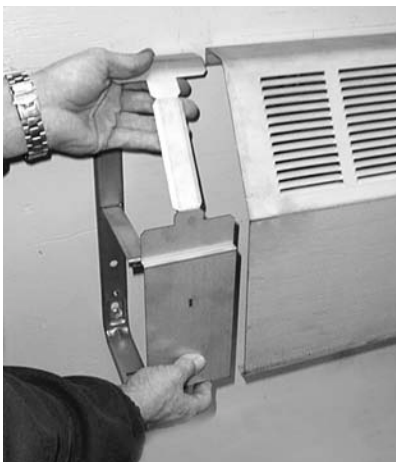

### Step 2:

Insert the internal splice plate just shy of the halfway slots. Slots must remain visible and not slide under cover.



### Step 3:

Insert screws, nails or slotted screw drivers into the 2 halfway slots of the internal splice plate to hold it in the correct location and prevent the halfway slots from sliding under cover.

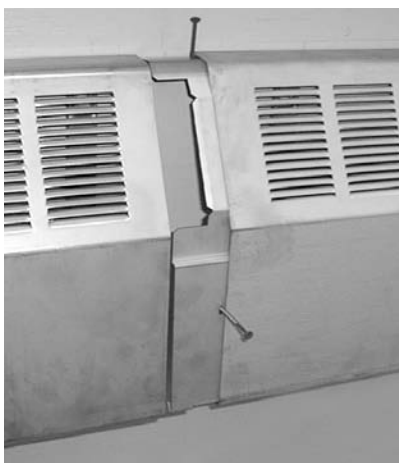

### Step 4:

Place the next cover in place on support brackets.



### Step 5:

Slide the next cover over the internal splice plate up to the screws, nails or slotted screw drivers.



### Step 6:

Remove the 2 screws, nails or screw drivers.



### Step 7:

Continue sliding cover sections together until a snug fit is obtained.

**Note:** Product shown is unpainted and does not represent finished installation.