

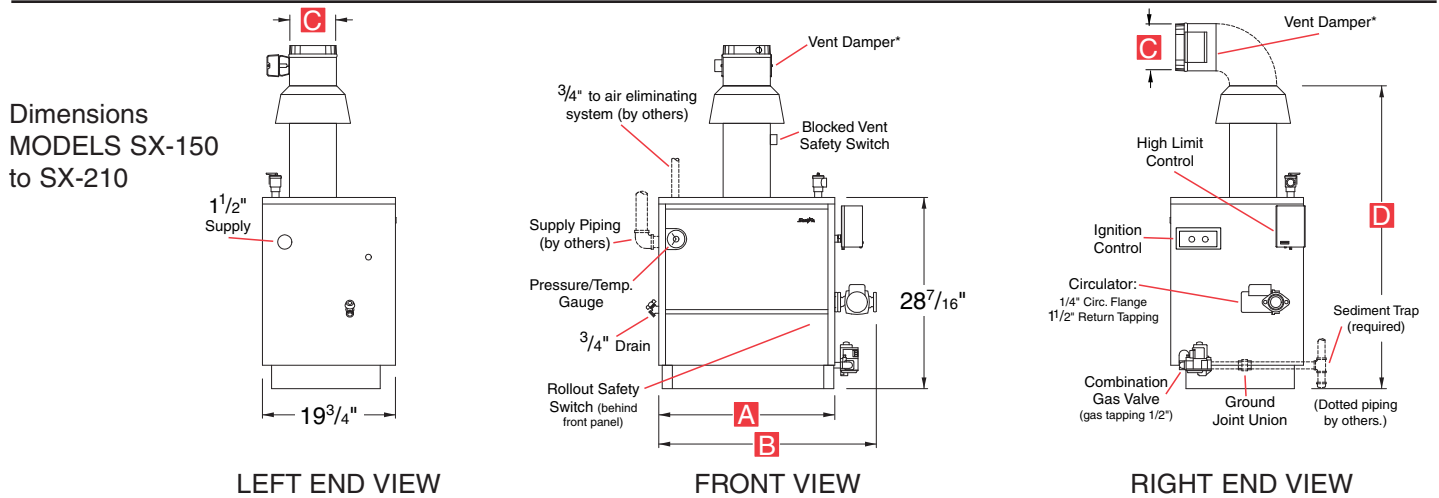

DIMENSIONS – GAS BOILERS

SENTRY

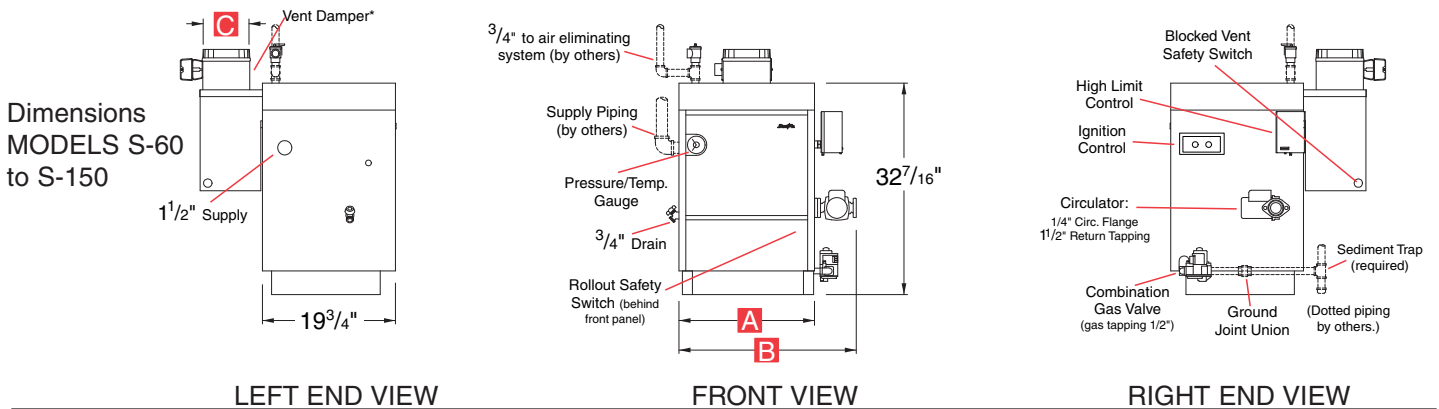
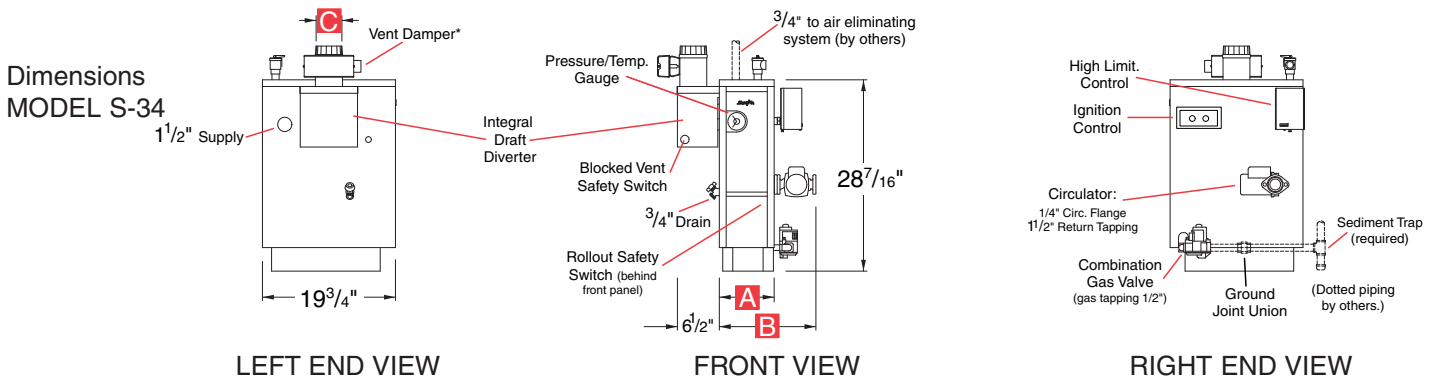

*Vent damper may be installed horizontally on all models with use of a common vent elbow.



MODEL NUMBER	DIMENSIONS-Inches				
	A	B	C-VENT DIAMETER		
			INTEGRAL DRAFT DIVERTER	EXTERNAL DRAFT HOOD	
D					
S-34	8 1/8"	14 5/8"	4	—	—
S-60	11 1/8"	17 5/8"	4	—	—
S-90	14 1/8"	20 5/8"	5	—	—
S-120	17 1/8"	23 5/8"	6	—	—
S-150	20 1/8"	26 5/8"	7	—	—
SX-150	20 1/8"	26 5/8"	—	6	47
SX-180	23 1/8"	29 5/8"	—	7	48 3/16"
SX-210	26 1/8"	32 5/8"	—	7	48 3/16"