

VHS SERIES

**Slant/Fin**



Look for our  
Hydronic Explorer app on  
iTunes and Google Play!  
(Works on iPad, iPhone & Android devices)

# VICTORY II

High Performance, Cast-iron, Power Vent Gas Boiler

The perfect boiler for new construction or replacement boiler for older homes.



- Thermal targeting technology to conserve fuel
- Near zero CO emissions
- LWCO function
- 30,000 to 180,000 Btuh CSA input
- Thermal pre-purge option
- LED display for operational info

## Contractor-friendly features speed installation and reduce service time.

Design innovations developed with the installer in mind make the Victory II easier to install and service. Boilers are fully packaged and ready to install. We even include additional flue system components, assembled with the boiler at the factory, saving field purchase cost and installation time.

**Horizontal flue discharge components** are factory installed to save field assembly.

**3-inch flue connector** with integral adapter for easy connection to stainless steel venting.

**Drain tube for condensate** is factory installed and pre-configured with water trap.

**Intermittant pilot "spark" ignition** saves energy.

**Ignition control, Hydrostat temperature control and gas valve** are included for reliability.

**Junction box** for line voltage facilitates placement and wiring of shut-off switch.

**Pressure switch** is the same for all boiler sizes and all altitudes.

**Controls**, circulator pump and other "trim" are top quality brand names that are widely available to heating professionals and easy to service.

## Flexibility in venting.

A wide variety of options permit you to select the most practical and economical venting method. Consult the Victory II boiler installation instructions for complete details and restrictions on these venting options:

**For side wall or through the roof power (pressure) venting** -- Easy, economical horizontal or vertical power venting with 3" diameter AL29-4C stainless steel pipe. Several brands of venting material are approved. Some restrictions apply.

**Chimney or type "B" venting** -- with galvanized or stainless steel pipe. Natural draft venting for VHS-90 through VHS-180 boilers

Since 1949  
**Slant/Fin**  
BOILERS & BASEBOARD  
We Build Trust and Comfort



[www.slantfin.com](http://www.slantfin.com)

# VICTORY II VHS

## Features

1. Insulated jacket
2. Cast iron heat exchanger
3. Thermal pins
4. Metal push nipples (Avoids leaks)
5. Insulated base
6. Long life stainless steel burners
7. Rollout safety switch
8. Gas valve
9. Junction box
10. Brand name controls
11. Power vent
12. Horizontal flue discharge

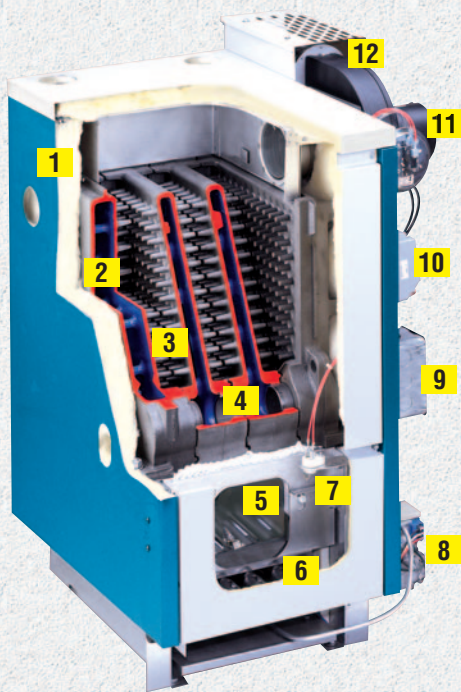

**PACKAGED WATER BOILER** includes: Pre-assembled cast-iron heat exchanger with built-in air eliminator, Insulated Base, Pre-assembled insulated flush jacket, Gas burners, Gas orifices and manifold assembly, Combination gas valve - including manual shut-off, pressure regulator and pilot adjustment, Intermittent pilot ignition system, Pressure and temperature gauge, LWCO function, Control w/LED and display, Pressure relief valve (ASME)\*\* , Circulator 1-1/4", Circulator 1-1/4", Drain cock, Inducer assembly, Air flow proving switch, Built-in condensate drain, Trap and stainless steel vent pipe adapter, and Rollout safety switch. *For propane, specify when ordering.*

**OPTIONAL EQUIPMENT:** Air package consisting of diaphragm expansion tank, fill and pressure reducing valve, and automatic air vent. Combustible floor kit. AL 29-4C<sup>▲</sup> stainless steel venting material, outdoor reset kit.

\*\* Boilers are factory equipped with 30 psi A.S.M.E. relief valves. Boilers are rated for 50 psi working pressure.

## RATINGS FOR NATURAL AND L.P. GAS

MODEL No.	RATINGS FOR WATER		NET AHRI WATER (Btuh)†	NET WATER (Sq. ft)‡	EFFICIENCY (A.F.U.E.)
	CSA INPUT (Btuh)	D.O.E. CAPACITY (Btuh)			
VHS-30	30,000	26,000	23,000	153	84.5
VHS-60	60,000	50,000	43,000	287	83.4
VHS-90	90,000	75,000	65,000	433	82.8
VHS-120	120,000	100,000	87,000	580	82.2
VHS-150	150,000	125,000	109,000	727	82.1
VHS-180	180,000	149,000	130,000	867	82.0

† Ratings must be reduced by 4% at 2,000 feet elevation and an additional 4% for every additional 1,000 feet elevation over 2,000 feet. Net ratings shown include allowance from normal piping loss and pick-up load. For installations having unusual piping and pick-up requirements, additional allowances should be made before selecting the size of boiler required. Ratings are based on a piping and pick-up factor 1.15.

‡ Based on heat emission rate of 150 Btu per square foot.

Note: All boilers under 300,000 Btu/h input are tested and rated for capacity under the U.S. Dept. of Energy (D.O.E.) Test Procedure for Boilers.

## Victory VHS boiler minimum clearances for combustible construction

(See installation instructions for further details.)

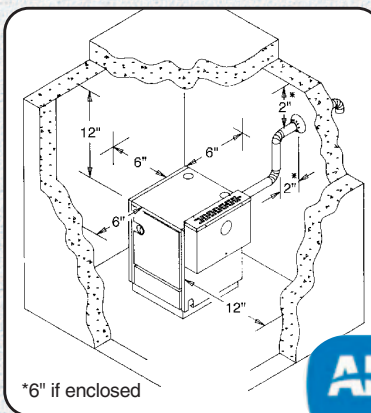

### MAX EQUIVALENT FLUE LENGTH

40 ft. for all models. May differ for certain vent system manufacturers and altitudes. See installation instructions, Pub. VHS-40.



## DIMENSIONS

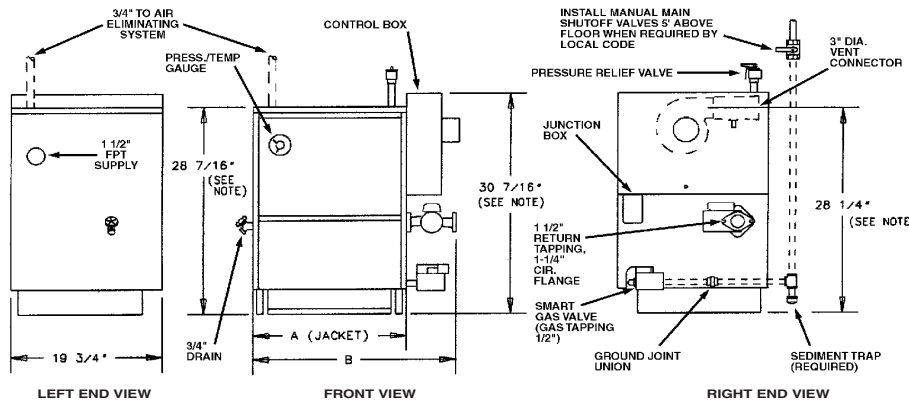

NOTE: Height dimensions increase by 1 1/4" and depth increases to 22 1/4" when combustible floor kit is used.

Supply water tapping	1 1/2"
Circulator return flange*	1 1/4"
Gas tapping, natural or propane	1/2"

\* When not equipped with circulator, boiler 1-1/2" return tapping. Crate dimensions: 34-5/8" length, 22-1/2" width, 33-1/2" height.

▲ AL 29-4C is a registered trademark of Allegheny Ludlum Corp.

Dimensions	VHS-30	VHS-60	VHS-90
"A"	8 1/2"	11 1/2"	14 1/2"
"B"	14 5/8"	17 5/8"	20 5/8"

Dimensions	VHS-120	VHS-150	VHS-180
"A"	17 1/2"	20 1/2"	23 1/2"
"B"	23 3/4"	26 3/4"	29 3/4"



**U.S.A.**  
Slant/Fin Corporation • 100 Forest Drive  
Greenvale, NY 11548 • 516-484-2600  
www.slantfin.com

**Canada**  
Slant/Fin LTD/LTEE • 400 Ambassador Drive,  
Mississauga, Ontario L5T 2 J3 • 905-677-8400  
www.slantfin.ca