

10 - INSTALLATION - Vent and combustion air

2. insert the clamp "D" into convertor "A" in the "C" side.
3. insert the adapter "E" into connection "C" of the convertor "A";
4. use the precedent clamp "D" to mechanically secure the adapter "E" to the adapter "A". To do this tighten the half clamp on the adapter "A" and half clamp on the adapter "E".
5. insert the clamp "F" into convertor "E".
6. insert the air inlet PVC/CPVC pipe, for 2" into the adapter "E";
7. use the precedent clamp "F" to mechanically secure the pipe to

the adapter "E". To do this tighten the half clamp on the pipe and half clamp to the adapter "E". Tight the clamps with a tork of 1.5 - 2 lbf ft (2-3 Nm).

Vent connection (see Figure 10-8 Item "B").

This connection is used to provide a passageway for conveying combustion gas to the outside. Vent piping must be supported per the National Building Code, Section 305, Table 305.4 or as local codes dictate.

To connect a PVC/CPVC pipe to the vent connection proceed as follow while referring to Figure 10-8:

1. install boiler adapter "A" above boiler. Rotate boiler adapter "A" so as air intake and vent connections are in the desired left or right side. Check stamped arrow to understand which is the vent and air intake connection.

! WARNING!!! Check stamped arrow on boiler adapter for the correct side of vent. Failure to follow this warning could result in excessive levels of carbon monoxide or a fire, which can result in severe personal injury or death!

2. Insert one side of clamp "D" onto the air intake of boiler adapter "A" (side C).
3. Insert adapter "E" into side "C" of boiler adapter "A";
4. Use clamp "D" to mechanically secure adapter "E" to boiler adapter "A". To do this, tighten one side of clamp "D" onto boiler adapter "A" and the other half of clamp "D" onto adapter "E". Tight the clamps with a tork of 1.5 - 2 lbf ft (2-3 Nm).
5. Insert clamp "F" into adapter "E".
6. Insert the PVC/CPVC pipe "G", into adapter "E" for at least 2";
7. Use clamp "F" to mechanically secure pipe "G" to adapter "E". To do this, tighten one side of clamp "F" onto pipe "G" and the other side of clamp "F" to the adapter "E". Tight the clamps with a tork of 1.5 - 2 lbf ft (2-3 Nm).

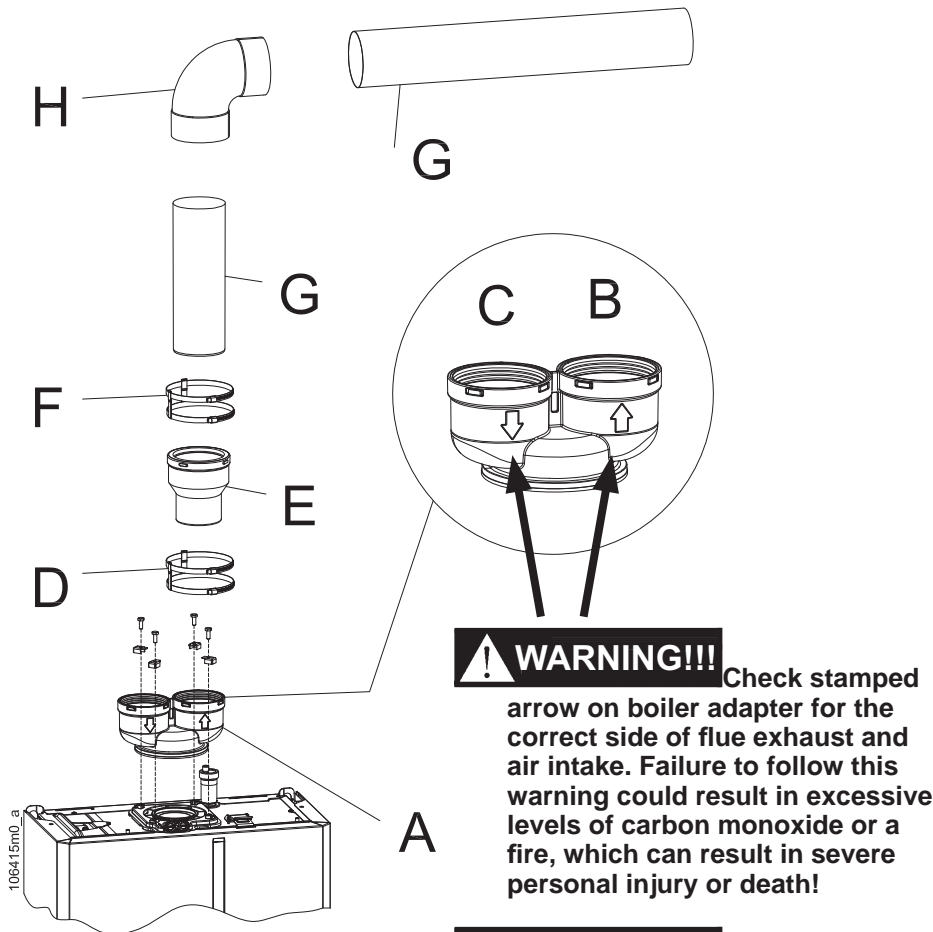

- A = Two pipes boiler adapter
- B = Flue exhaust connection
- C = Air intake connection
- D = Fixing clamp
- E = PVC/CPVC adapter
- F = Fixing clamp
- G = PVC/CPVC pipe
- H = 90° elbow

Figure 10-8 PVC/CPVC Venting connection

10 - INSTALLATION - Vent and combustion air

10.8 - Stainless steel vent piping materials

! WARNING!!! Use only the materials, vent systems, and terminations listed in Tables 10-1 and 10-2. DO NOT mix vent systems of different types or manufacturers, unless listed in this manual. Failure to comply could result in severe personal injury, death, or substantial property damage.

! WARNING!!! This appliance requires a special venting system. The field provided vent fittings must be connected to the boiler following Section 10.8.1. Failure to follow this warning could result in fire, personal injury, or death.

! WARNING!!! Improper installation of Stainless steel systems may result in injury or death.

! WARNING!!! Use only water-based lubricants on joints. Never use hydrocarbons-based lubricants because they would destroy gaskets. Failure to follow this warning could result in excessive levels of carbon monoxide, which can result in severe personal injury or death!

NOTICE Installation must comply with local requirements and with the National Fuel Gas Code, ANSI Z223.1 for U.S. installations or CSA B149.1 for Canadian installations.

For installation in Canada, vent pipe system must be certified to ULC-S636 (see Table 10-1).

NOTICE All vent pipes connections must be secured following manufacturer instruction, properly supported, and the exhaust must be pitched a minimum of a 1/4 inch per foot back to the boiler (to allow drainage of condensate).

NOTICE Installation of a stainless steel vent system should adhere to the stainless steel vent manufacturer's installation instructions supplied with the vent system.

NOTICE The installer must use a specific vent starter adapter at the flue collar connection, supplied by the vent manufacturer to adapt to its vent system. See Table 10-2 for approved vent adapters.

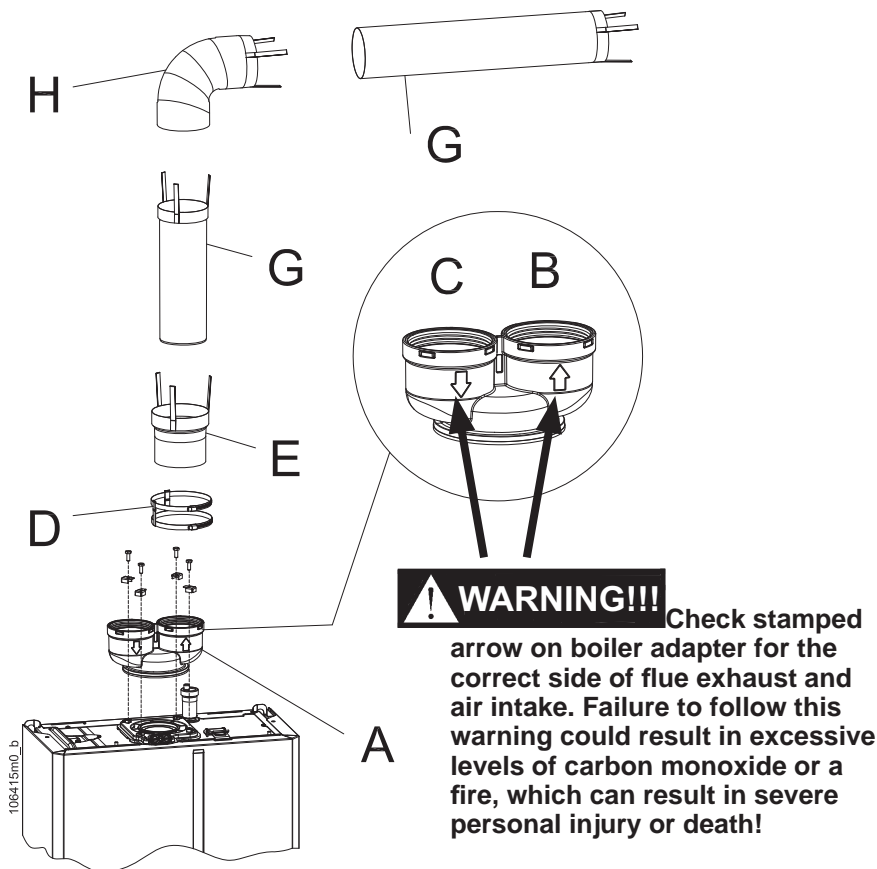

- A = Flue exhaust connection
- B = Combustion air intake connection
- C = Fixing clamp
- D = Stainless steel elbow
- E = Stainless steel adaptor
- F = Stainless steel extension
- G = Air intake pipe

Figure 10-9 Stainless Steel Venting connection

10 - INSTALLATION - Vent and combustion air

10.8.1 - Stainless steel air intake/vent connections

Combustion Air Intake connection (see Figure 10-9 Item "C"). This connection is used to provide combustion air directly to the boiler from outdoors. Combustion air piping must be supported per guidelines listed in the National Mechanical Code, Section 305, Table 305.4 or as local codes dictate. To connect a PVC/CPVC pipe to the air intake connection follow section 10.7.2.

Vent connection (Figure 10-9 item "A") is used to provide a passageway for conveying combustion gases to the outside. Vent piping must be supported per the National Building Code, Section 305, Table 305.4 or as local codes dictate.

To connect a stainless steel pipe to the vent connection proceed as follow: while referring to Figure 10-9:

1. install boiler adapter "A" above boiler. Rotate boiler adapter "A" so as air intake and vent connections are in the desired left or right side. Check stamped arrow to understand which is the vent and air intake connection.



WARNING!!!

Check stamped arrow on boiler adapter for the correct side of vent. Failure to follow this warning could result in excessive levels of carbon monoxide or a fire, which can result in severe personal injury or death!

2. Insert clamp "D" onto side "B" of boiler adapter "A" .
3. Insert adapter "E" into side "B" of boiler adapter "A";
4. Use clamp "D" to mechanically secure adapter "E" to boiler adapter "A". To do this tighten one side of clamp "D" onto boiler adapter "A" and the other half of clamp "D" onto adapter "E". Tight the clamps with a tork of 1.5 - 2 lbf ft (2-3 Nm).
5. Insert vent pipe "G", into adapter "E", following instruction of stainless steel pipe manufacturer.

10 - INSTALLATION - Vent and combustion air

10.9 - Polypropylene vent piping materials

! WARNING!!! Use only the materials listed in Tables 10-1 and 10-2 for vent pipe, and fittings. **DO NOT** mix vent systems of different types or manufacturers, unless listed in this manual. Failure to comply could result in severe personal injury, death, or substantial property damage.

! WARNING!!! This appliance requires a special venting system. The field provided vent fittings must be connected to the boiler following Section 10.9.1. Failure to follow this warning could result in fire, personal injury, or death.

! WARNING!!! Improper installation of Polypropylene systems may result in injury or death.

! WARNING!!! Use only water-based lubricants on joints. Never use hydrocarbons-based lubricants because they would destroy gaskets. Failure to follow this warning could result in excessive levels of carbon monoxide, which can result in severe personal injury or death!

NOTICE Installation must comply with local requirements and with the National Fuel Gas Code, ANSI Z223.1 for U.S. installations or CSA B149.1 for Canadian installations.

For installation in Canada, vent pipe system must be certified to ULC-S636 (see Table 10-1).

NOTICE All vent pipes connections must be secured following manufacturer instruction, properly supported, and the exhaust must be pitched a minimum of a 1/4 inch per foot back to the boiler (to allow drainage of condensate).

NOTICE Installation of a Polypropylene vent system should adhere to the polypropylene vent manufacturer's installation instructions supplied with the vent system.

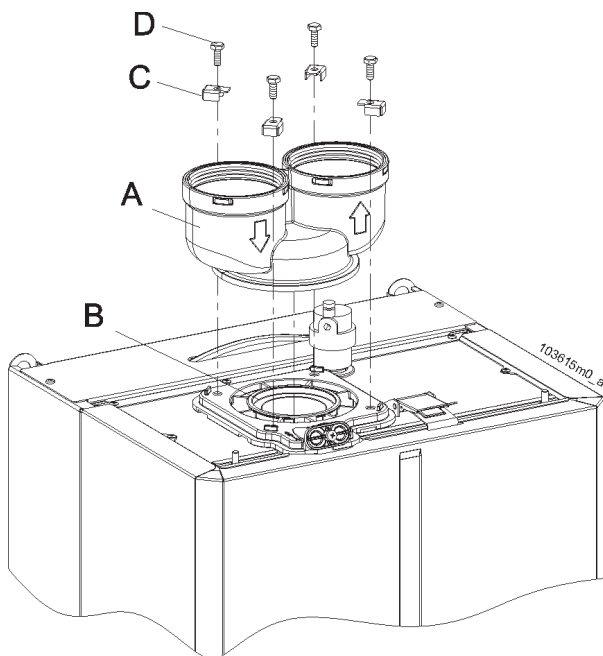

Figure 10-10 Polypropylene boiler adaptor

10 - INSTALLATION - Vent and combustion air

10.9.1 - Polypropylene two pipes air intake/vent connections

Combustion air piping and vent piping must be supported per guidelines listed in the National Mechanical Code, Section 305, Table 305.4 or as local codes dictate.

The boiler is not supplied with the fittings needed for separate vent and combustion air systems. A special kit must be ordered to connect the boiler to separate vent and combustion air

systems. Figure 10-10 shows fitting "A" that can freely turn 360 degrees for optimum installation versatility (see section 10.9.2 for P/N of "A" fitting).
Tork screws "D" at 2 lbf ft (3 Nm).

Pipes or elbows connected directly to the boiler, must be mechanically secure. Follow these instructions to connect pipes to the boiler (make reference to Figure 10-11):

1. Prepare the two collars "G" with Band Clamps "E" and "F";
2. Insert the end of Band Clamp "L"

3. Insert vent pipe "N" into boiler adapter "A"
4. Tight the two Band Clamps "O" to mechanically secure vent pipe "N" to boiler adapter "A". Tight band clamps with a tork of 1.5 - 2 lbf ft (2-3 Nm).

The vent system must be both gas tight and watertight. All seams and joints must be joined and sealed in accordance with the vent system manufacturer's instructions.

! WARNING!!! Carefully follow the installation steps below for the assembling the two pipes venting system (elbows and extensions), as illustrated in Figure 10-12. It is necessary to properly insert the male side onto the female side and mechanically secure them by using the proper clamps. Improper venting can result in excessive levels of carbon monoxide or a fire, which can result in severe personal injury or death!

- ☞ Mechanically secure each joint with the supplied band clamps as shown in Figure 10-12. Follow this procedure:
 1. Insert the Male side ("B") of a vent pipe into the Female side "A" of another;
 2. Use Band Clamp "C" to keep the two pipes together;
 3. Use screws "E" to tighten the Band Clamp onto both pipes. Tight band clamps with a tork of 1.5 - 2 lbf ft (2-3 Nm).

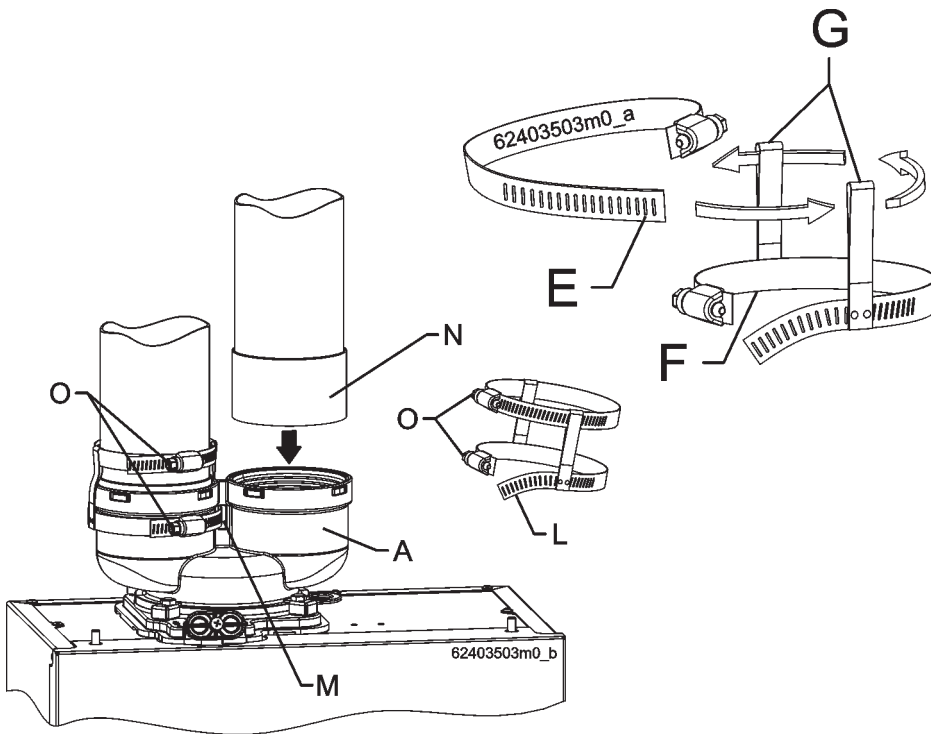

Figure 10-11 Polypropylene Venting connection

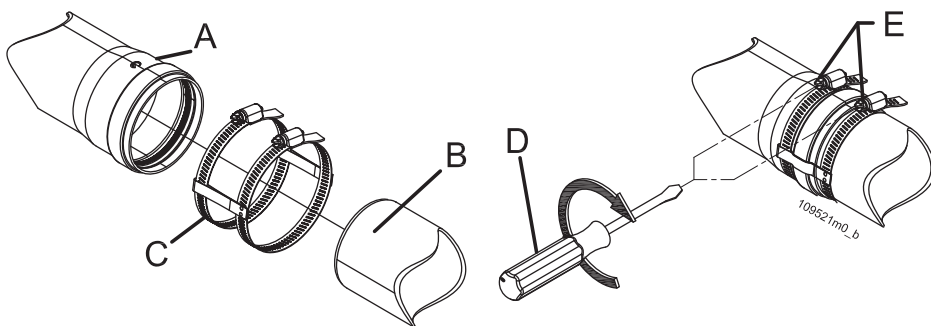
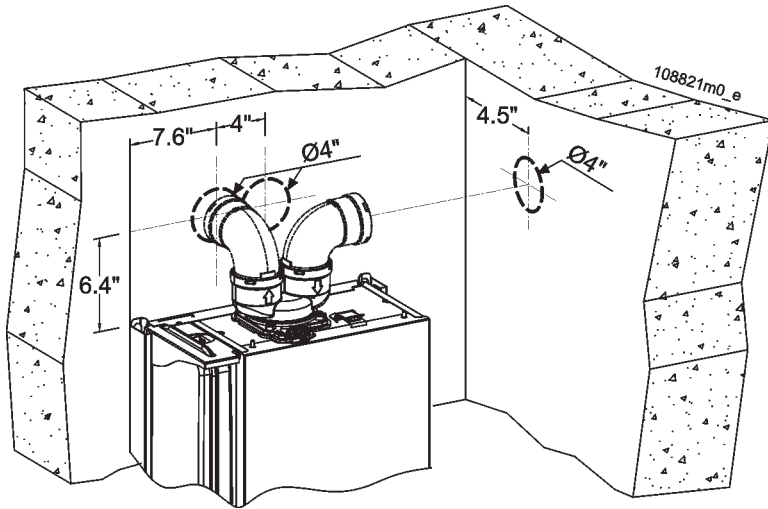

Figure 10-12 Connecting extensions and elbows

10 - INSTALLATION - Vent and combustion air



10.9.2 - Polypropylene two pipes system components

Some of the most commonly used components for installing the two pipes polypropylene vent and combustion air systems are listed below:

- P/N 81 9001 000 - Two pipes adaptor 80/80 PP
- P/N 81 9171 000 - 3ft PP M/F extension
- P/N 81 9772 000 - 60 ft PP flexible extension
- P/N 81 9173 000 - Spacer for PP flexible extension
- P/N 81 9003 000 - 90° PP M/F in line elbow
- P/N 81 9174 000 - 45° PP M/F in line elbow
- P/N 81 9175 000 - Secure clamp for PP extensions
- P/N 81 9177 000 - Split vertical terminal
- P/N 81 9181 000 - Air intake grid
- P/N 81 9182 000 - Flue exhaust grid

Figure 10-13 Dimensions of two pipes system

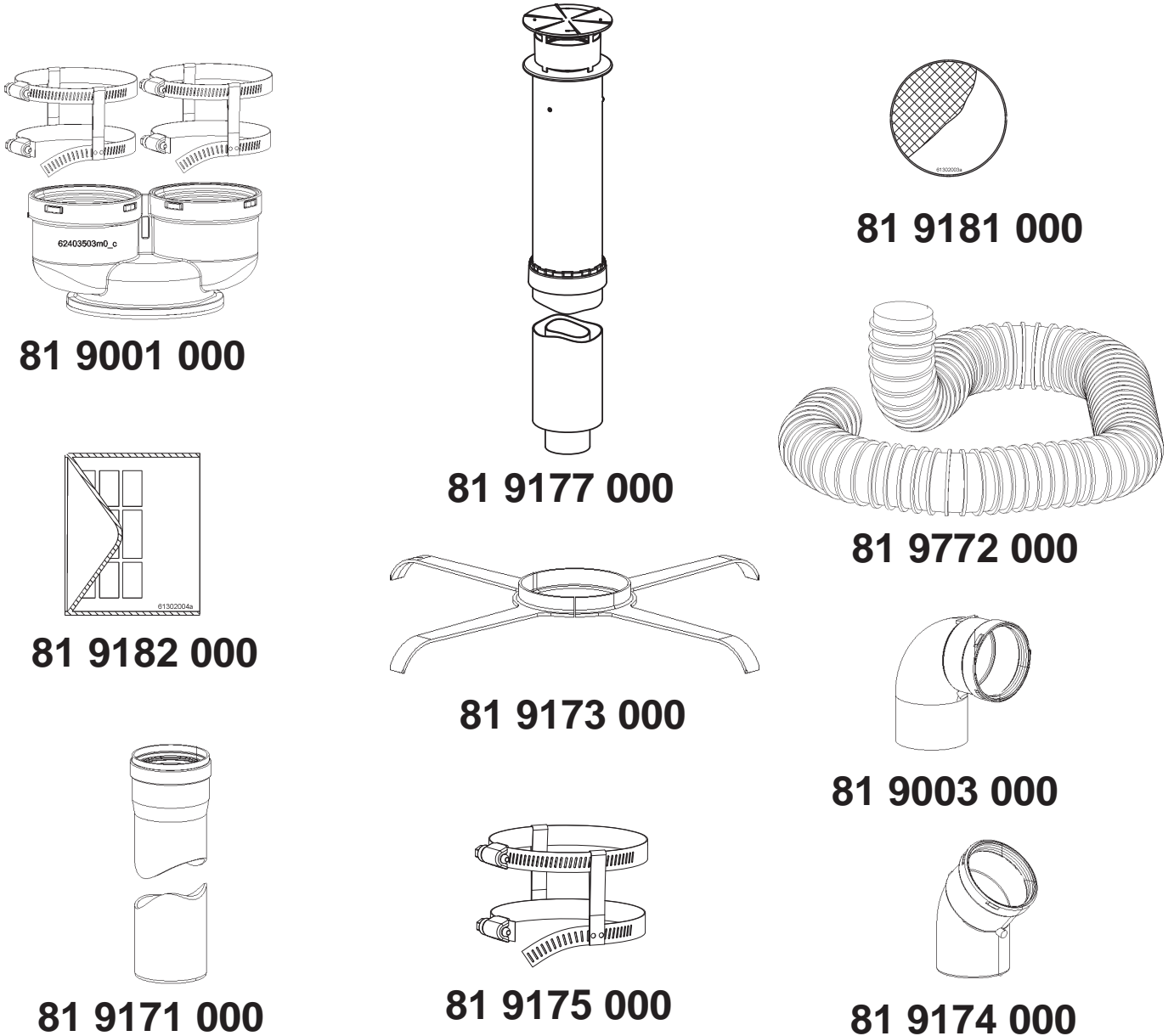

10 - INSTALLATION - Vent and combustion air

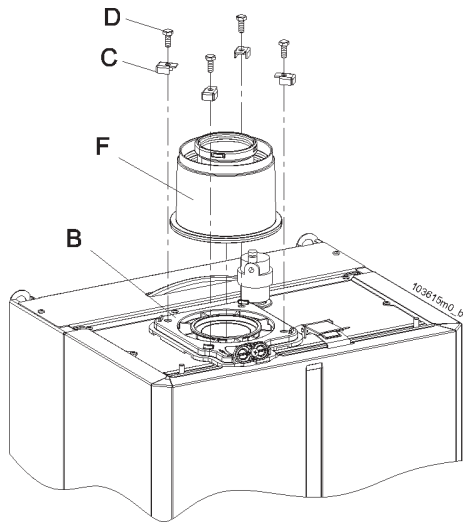

- B = Connection flange
- C = Fasten clip
- D = Fasten clip screw
- F = Coaxial vertical adaptor

Figure 10-14 Installation of the coaxial fitting

10.9.3 - Polypropylene concentric system

The boiler is not supplied with the fittings needed for connecting a coaxial vent/combustion air system. A special kit must be ordered to connect the boiler with the Coaxial polypropylene vent. Figure 10-14 shows how to install the Coaxial fitting above the boiler. Tight the screws "D" of Figure 10-14 with a tork of 2 lbf ft (3 Nm)

! WARNING!!! Carefully follow installation steps below, for the coaxial pipe assembly (elbows and extensions), as illustrated in Figure 10-15. It is necessary to properly insert the internal and external pipe and mechanically secure them by using a stainless steel self tapping screw. Improper venting can result in excessive levels of carbon monoxide or a fire, which can result in severe personal injury or death!

In particular:

1. slip-fit the extension "1" and "2" (see Figure 10-15) together;
2. drill a suitable hole "3" with a drill "4" (see Figure 10-15) in a position where the two pipes "1" and "2" are overlapped;
3. insert a suitable stainless steel self tapping screw "5" and tight it with a screwdriver "6"

☞ It is recommended that wall sleeve be used when installing the coaxial system through an exterior wall. This will allow the system to be easily slipped out for access during routine maintenance.

☞ Horizontal coaxial systems must always be pitched by at least 1/4 in/ft, (21 mm/m) towards the boiler.

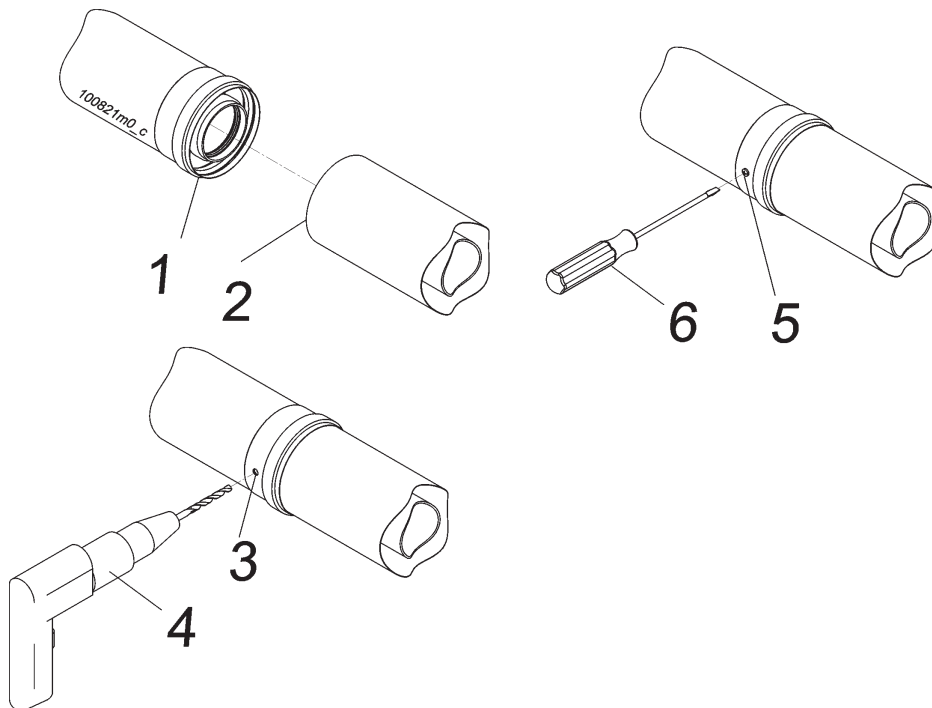
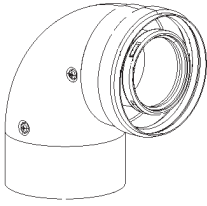

Figure 10-15 Securing extensions and elbows together

10 - INSTALLATION - Vent and combustion air



81 9183 000

10.9.4 - Polypropylene concentric system components

The following coaxial polypropylene vent and combustion air system components are available, on request, for installing the Coaxial system

- P/N 81 9183 000 - In line 90° PP coaxial M/F elbow
- P/N 81 9176 000 - In line 45° PP coaxial M/F elbow
- P/N 81 9170 000 - 3ft (1m) PP coaxial extension
- P/N 81 9005 000 - PP coaxial roof end piece
- P/N 81 9184 000 - PP Coaxial wall end piece
- P/N 81 9185 000 - PP straight coaxial adaptor

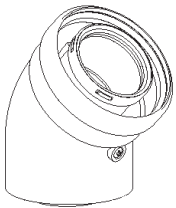

81 9176 000

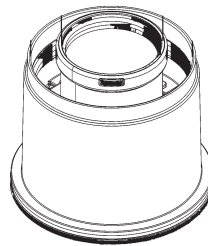

81 9185 000



81 9170 000

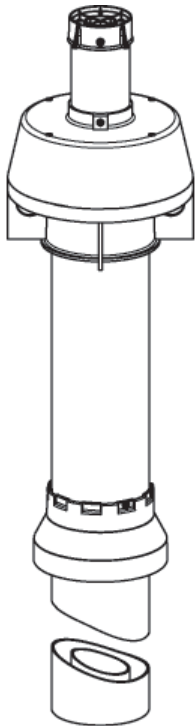

81 9005 000

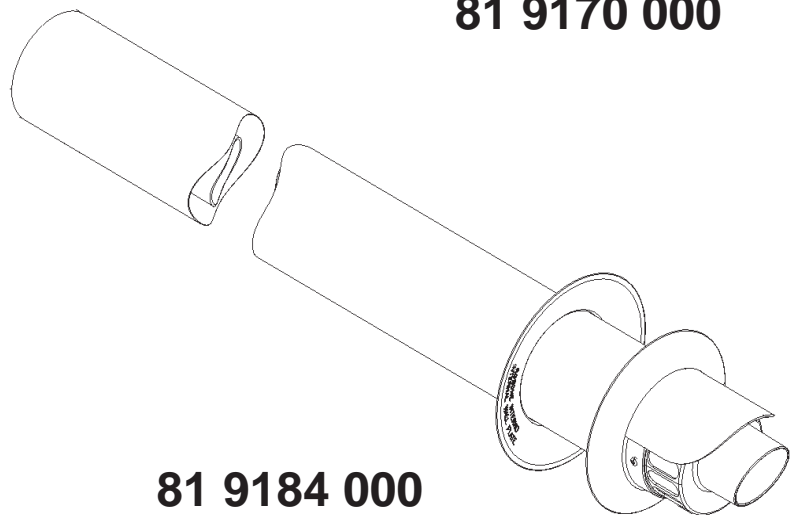

81 9184 000

10 - INSTALLATION - Vent and combustion air

10.10 - Single pipe vent (not sealed combustion)

! WARNING!!! When utilizing the single pipe method, provisions for combustion and ventilation air must be in accordance with Air for Combustion and Ventilation, of the latest edition of the National Fuel Gas Code, ANSI Z223.1, in Canada, the latest edition of CGA Standard B149 Installation Code for Gas Burning Appliances and Equipment, or applicable provisions of the local building codes.

Commercial applications utilizing this boiler may be installed with a single pipe carrying the flue products to the outside while using combustion air from the equipment room. In this case the following conditions and considerations must be followed.

! WARNING!!! The equipment room **MUST** be provided with properly sized openings to assure adequate combustion air from outside. Failure to comply could result in severe personal injury, death, or substantial property damage.

- There will be a noticeable increase in the noise level during normal operation from the inlet air opening.
- Vent system and terminations must comply with the venting instructions set forth in sections 10.1, 10.2, 10.3, 10.4, 10.5, 10.7, 10.8 and 10.9.

! WARNING!!! Use only the materials, vent systems, and terminations listed in Tables 10-1 and 10-2. **DO NOT** mix vent systems of different types or manufacturers, unless listed in this manual. Failure to comply could result in severe personal injury, death, or substantial property damage.

! WARNING!!! Fire danger due to flammable materials or liquids. Do not store flammable materials and liquids in the immediate vicinity of the boiler.

! WARNING!!! Boiler must be clear and free from combustible materials, gasoline and other flammable vapors and liquids, and corrosive liquids and vapors. Never use chlorine and hydrocarbon containing chemicals (such as spray chemicals, solution and cleaning agents, paints, glues etc.) in the vicinity of the boiler. Do not store and use these chemicals in the boiler room. Avoid excessive dust formation and build-up.

! WARNING!!! Where exhaust fans, clothes dryers, and kitchen ventilation systems interfere with the operation of appliances, makeup air shall be provided.

NOTICE Installation must comply with local requirements and with the National Fuel Gas Code, ANSI Z223.1 for U.S. installations or CSA B149.1 for Canadian installations.

For installation in Canada, vent pipe system must be certified to ULC-S636 (see Table 10-1).

NOTICE All vent pipes connections must be secured following manufacturer instruction, properly supported, and the exhaust must be pitched a minimum of a 1/4 inch per foot back to the boiler (to allow drainage of condensate).

10.10.1 - Combustion Air and Ventilation openings

! WARNING!!! Make sure that combustion air and ventilation openings are sufficiently sized and no reduction or closure of openings takes place. Please note these restrictions and its dangers to the operator of the boiler and to the homeowner. Failure to comply could result in severe personal injury, death, or substantial property damage.

Outdoor combustion air shall be provided through opening(s) to the outdoors. The minimum dimension of air openings shall not be less than 3 in. (80 mm) diameter.

Two Permanent Openings Method.

Two permanent openings, one commencing within 12 in. (300 mm) of the top and one commencing within 12 in. (300 mm) of the bottom, of the room shall be provided. The openings shall communicate directly, or by ducts, with the outdoors or spaces that freely communicate with the outdoors, as follows:

1. Where directly communicating with the outdoors or where communicating to the outdoors through vertical ducts, each opening shall have a minimum free area of 1 in² each 4000 Btu/hr (550 mm²/kW) of total input rating of all appliances located in the room.
2. Where communicating with the outdoors through horizontal ducts, each opening shall have a minimum free area of 1 in² each 2000 Btu/hr (1100 mm²/kW) of total input rating of all appliances located in the room.

One Permanent Opening Method.

One permanent opening, commencing within 12 in. (300 mm) of the top of the room, shall be provided. The appliances shall have clearances of at least 1 in. (25 mm) from the sides and back and 6 in. (150 mm) from the front of the appliance. The opening shall directly communicate with the outdoors or shall communicate through a vertical or horizontal duct to the outdoors or spaces that freely communicate with the outdoors and shall have a minimum free area of 1 in² each 3000 Btu/hr (700 mm²/kW) of the total input rating of all appliances located in the room.

10 - INSTALLATION - Vent and combustion air

10.10.2 - Determine location

Locate the vent termination using the following guidelines:

1. The total length of piping for vent must not exceed the limits given in the Section 10.4.
2. You must consider the surroundings when terminating the vent:
 - a. Position the vent termination where vapors will not damage nearby shrubs, plants or air conditioning equipment or be objectionable.
 - b. The flue products will form a noticeable plume as they condense in cold air. Avoid areas where the plume could obstruct window views.
 - c. Prevailing winds could cause freezing of condensate and water/ice buildup where flue products impinge on building surfaces or plants.
 - d. Avoid possibility of accidental contact of flue products with people or animals.

- e. Do not locate the terminations where wind eddies could affect performance or cause recirculation, such as inside building corners, near adjacent buildings or surfaces, window wells, stairwells, alcoves, courtyards, or other recessed areas.
- f. Do not terminate above any door or window. Condensate can freeze, causing ice formations.
- g. Locate or guard vent to prevent condensate damage to exterior finishes.
4. The vent piping must terminate in an elbow pointed outward as shown in Figure 10-12 or 10.13.



WARNING!!! Do not exceed the maximum lengths of the outside vent piping shown in Figures 10-12 or 10-13. Excessive length exposed to the outside could cause freezing of condensate in the vent pipe, resulting in potential boiler shutdown.

5. Maintain clearances as shown in Figure 10-11 (get references to "Mechanical draft vent terminal" only). Also maintain the following:
 - a. Vent must terminate:
 - At least 6 feet from adjacent walls.
 - No closer than 12 inches below roof overhang.
 - At least 7 feet above any public walkway.
 - At least 3 feet above any forced air intake within 10 feet.
 - No closer than 4 feet below or horizontally from any door or window or any other gravity air inlet.
 - b. Do not terminate closer than 4 feet horizontally from any electric meter, gas meter, regulator, relief valve, or other equipment. Never terminate above or below any of these within 4 feet horizontally. **Item unique to CANADA: vent system shall terminate at least 6 ft from electrical and gas meters.**
6. Locate termination so it is not likely to be damaged by foreign objects, such as stones or balls, or subject to buildup of leaves or sediment.

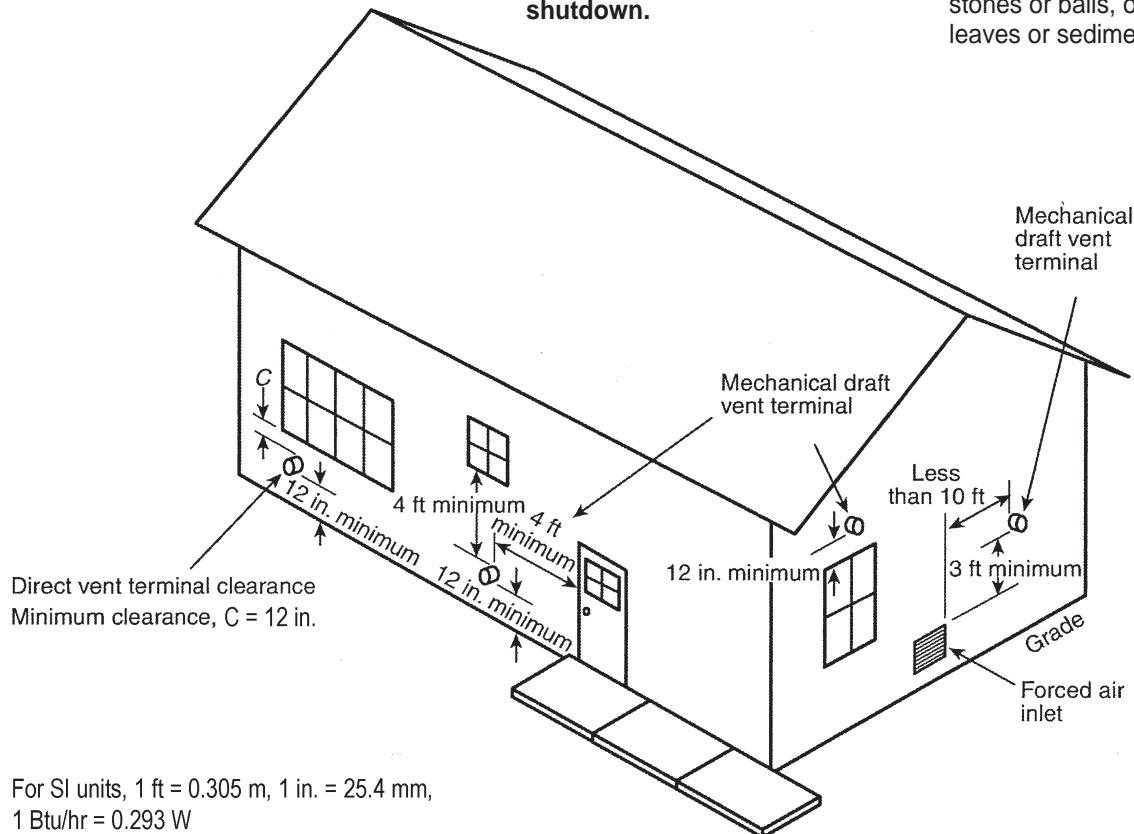

For SI units, 1 ft = 0.305 m, 1 in. = 25.4 mm,
1 Btu/hr = 0.293 W

NFPA54FIG-A12.9

CAUTION!!! Increase the grade clearances of the snow line quote

Figure 10-16 Vent position of a Direct vent boiler and of a Mechanical draft boiler (not sealed)

10 - INSTALLATION - Vent and combustion air

10.11 - Sidewall termination - Two pipes

10.11.1 - Vent/air termination

 **WARNING!!!** A gas vent extending through an exterior wall shall not terminate adjacent to a wall or below building extensions such as eaves, parapets, balconies, or decks. Failure to comply could result in severe personal injury, death, or substantial property damage.

 **WARNING!!!** Do not connect any other appliance to the vent pipe or multiple boilers to a common vent pipe. Failure to comply could result in severe personal injury, death, or substantial property damage.

NOTICE Installation must comply with local requirements and with the National Fuel Gas Code, ANSI Z223.1 for U.S. installations or CSA B149.1 for Canadian installations.

10.11.2 - Determine location

Locate the vent/air terminations using the following guidelines:

1. The total length of piping for vent or air must not exceed the limits given in the Section 10.4.
2. You must consider the surroundings when terminating the vent and air:
 - a. Position the vent termination where vapors will not damage nearby shrubs, plants or air conditioning equipment or be objectionable.
 - b. The flue products will form a noticeable plume as they condense in cold air. Avoid areas where the plume could obstruct window views.
 - c. Prevailing winds could cause freezing of condensate and water/ice buildup where flue products impinge on building surfaces or plants.
 - d. Avoid possibility of accidental contact of flue products with people or animals.
 - e. Do not locate the terminations where wind eddies could affect performance or cause recirculation, such as inside building corners, near adjacent buildings or surfaces, window wells, stairwells, alcoves, courtyards, or other recessed areas.
 - f. Do not terminate above any door or window. Condensate can freeze, causing ice formations.
 - g. Locate or guard vent to prevent condensate damage to exterior finishes.

10 - INSTALLATION - Vent and combustion air

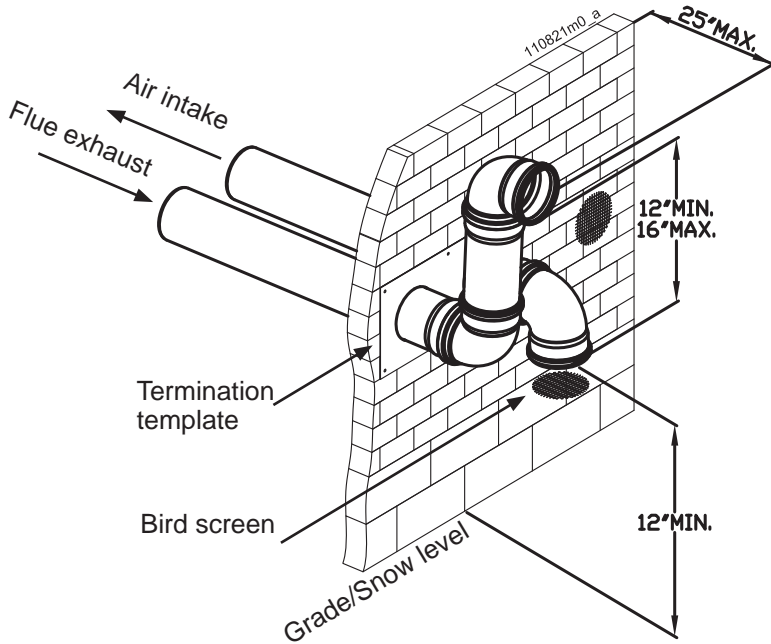

Figure 10-17 Two pipes sidewall termination of air and vent

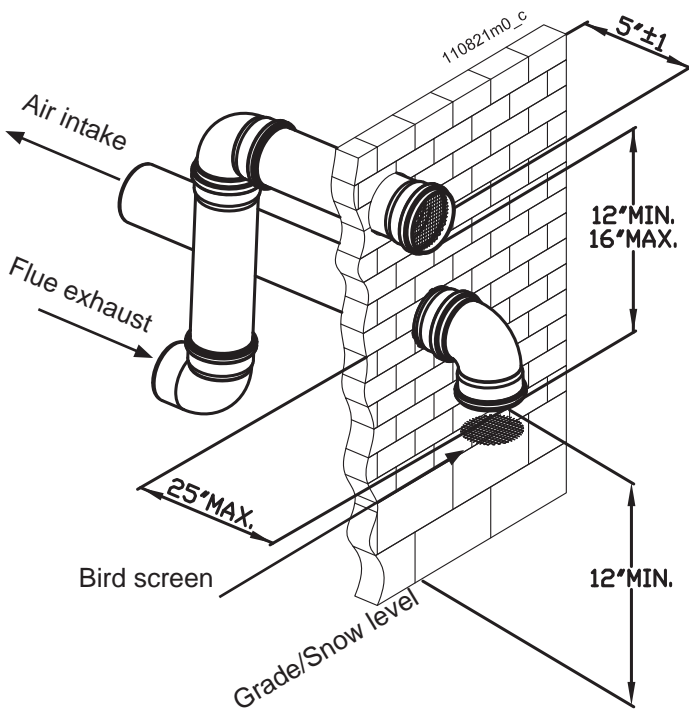

Figure 10-18 Two pipes sidewall termination of air and vent (if space permits)

3. The air piping must terminate in a down-turned elbow as shown in Figures 10-17 and 10-18. This arrangement avoids recirculation of flue products into the combustion air stream.
4. The vent piping must terminate in an elbow pointed outward or away from the air inlet, as shown in Figures 10-17 and 10-18.

! WARNING!!! Do not exceed the maximum lengths of the outside vent piping shown in Figures 10-17 and 10-18. Excessive length exposed to the outside could cause freezing of condensate in the vent pipe, resulting in potential boiler shutdown.

5. Maintain clearances as shown in Figures 10-17 and 10-18. Also maintain the following:
 - a. Vent must terminate:
 - At least 6 feet from adjacent walls.
 - No closer than 12 inches below roof overhang.
 - At least 7 feet above any public walkway.
 - At least 3 feet above any forced air intake within 10 feet.
 - No closer than 12 inches below or horizontally from any door or window or any other gravity air inlet.
 - b. Air inlet must terminate at least 12 inches above grade or snow line; at least 12 inches below the vent termination;
 - c. Do not terminate closer than 6 feet horizontally from any electric meter, gas meter, regulator, relief valve, or other equipment. Never terminate above or below any of these within 6 feet horizontally.
6. Locate terminations so they are not likely to be damaged by foreign objects, such as stones or balls, or subject to buildup of leaves or sediment.

10 - INSTALLATION - Vent and combustion air

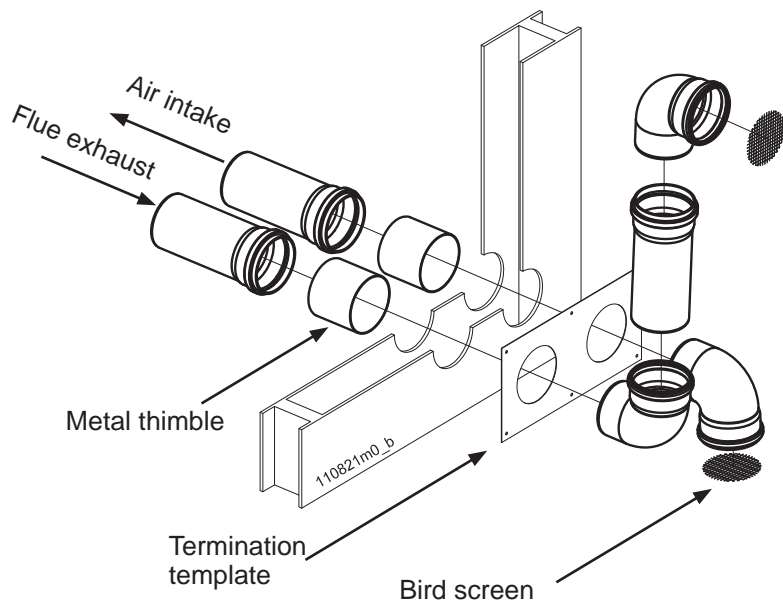
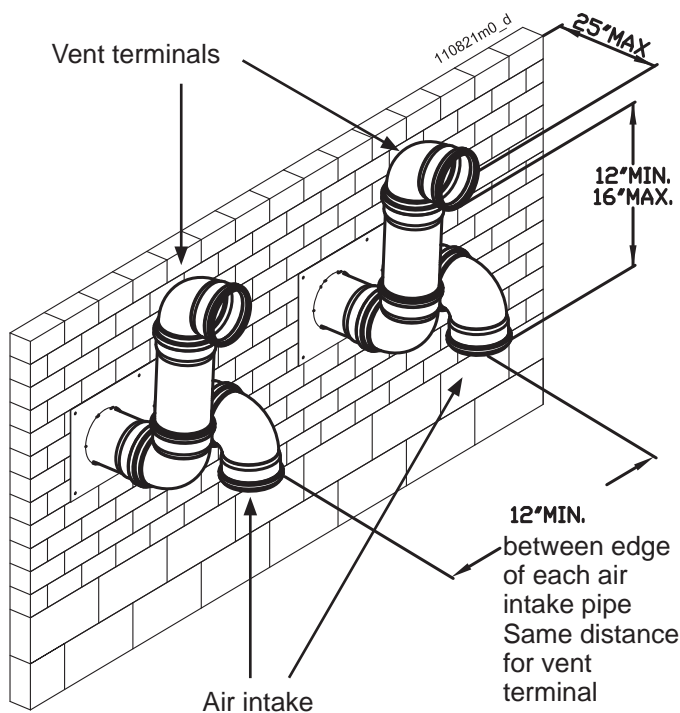

Figure 10-19 Two pipes sidewall termination assembly



NOTE: keep the air intake at min. 12" from grade or snow line. Provide vent and air intake with bird screen

Figure 10-20 Two pipes multiple boilers vent terminations

10.11.3 - Prepare wall penetrations

1. Air pipe penetration:
 - a. Cut a hole for the air pipe. Size the air pipe hole as close as desired to the air pipe outside diameter.
2. Vent pipe penetration:
 - a. Cut a hole for the vent pipe. For either combustible or noncombustible construction, size the vent pipe hole with at least a 1/2 inch clearance around the vent pipe outer diameter (4½ inch hole for 3 inch vent pipe)
 - b. Insert a galvanized metal thimble in the vent pipe hole as shown in Figure 10-19.
3. Use a sidewall termination plate as a template for correct location of hole centers.
4. Follow all local codes for isolation of vent pipe when passing through floors or walls.
5. Seal exterior openings thoroughly with exterior caulk.

10.11.4 - Termination and fittings

1. The air termination coupling must be oriented at least 12 inches above grade or snow line as shown in Figures 10-17 and 10-18.
2. Maintain the required dimensions of the finished termination piping as shown in Figures 10-17 and 10-18.
3. Do not extend exposed vent pipe outside of the building more than what is shown in Figures 10-17 and 10-18. Condensate could freeze and block vent pipe.

10.11.5 - Multiple vent/air terminations

1. When terminating multiple boilers terminate each vent/air connection as shown in Figure 10-20.

! WARNING!!!

All vent pipes and air inlets must terminate at the same height to avoid possibility of severe personal injury, death, or substantial property damage.

2. Place wall penetrations to obtain minimum clearance of 12 inches between edge of air inlet and adjacent vent outlet, as shown in Figure 10-20 for U.S. installations. For Canadian installations, provide clearances required by CSA B149.1 Installation Code.
3. The air inlet is part of a direct vent connection. It is not classified as a forced air intake with regard to spacing from adjacent boiler vents.

10 - INSTALLATION - Vent and combustion air

10.12 - Sidewall termination – Concentric vent

10.12.1 - Description and usage

The termination kit must terminate outside the structure and must be installed as shown in Figure 10-21. The required concentric termination kit as well as combustion air and vent pipe materials are listed in Tables 10-1 and 10-2.

10.12.2 - Sidewall termination installation

1. Determine the best location for the termination kit (see Figure 10-21).
2. The total length of piping for vent or air must not exceed the limits given in Section 10-4.
3. You must consider the surroundings when terminating the vent and air:
 - a. Position the vent termination where vapors will not damage nearby shrubs, plants or air conditioning equipment or be objectionable.
 - b. The flue products will form a noticeable plume as they condense in cold air. Avoid areas where the plume could obstruct window views.
 - c. Prevailing winds could cause freezing of condensate and water/ice buildup where flue products impinge on building surfaces or plants.
 - d. Avoid possibility of accidental contact of flue products with people or animals
 - e. Do not terminate above any door or window. Condensate can freeze, causing ice formations.
 - f. Locate or guard vent to prevent condensate damage to exterior finishes.
4. Cut one (1) hole 5 inch diameter into the structure to install the termination kit.
5. Install the Concentric vent kit following the concentric kit manufacturer's instruction.

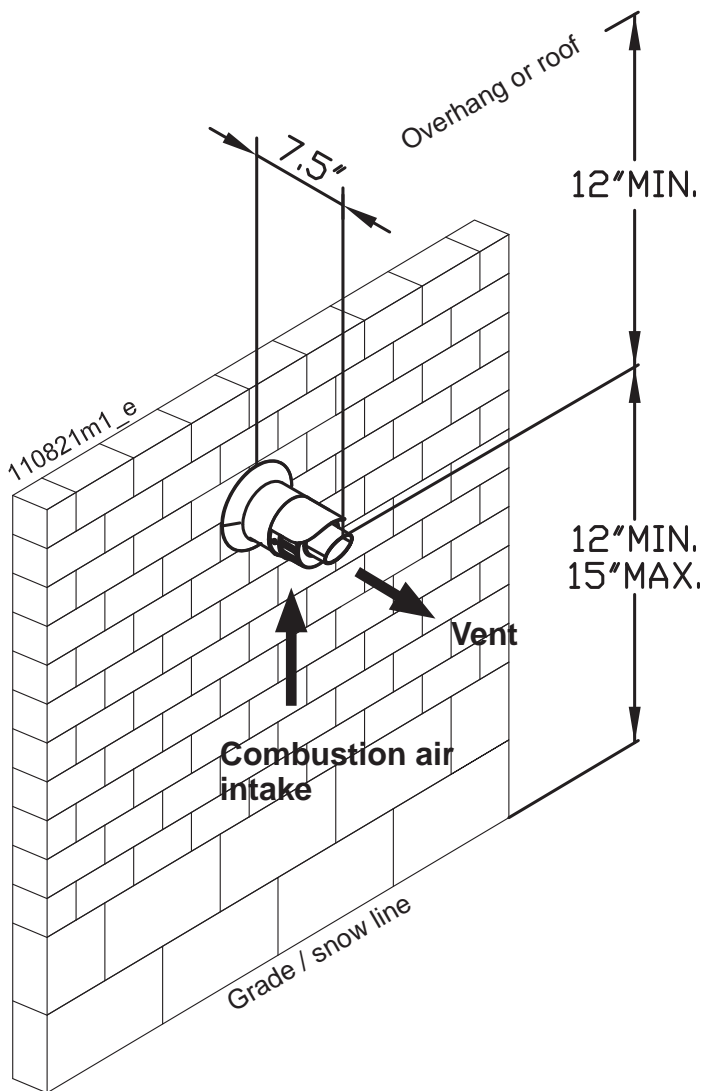

Figure 10-21 Concentric sidewall termination clearances

NOTICE Ensure termination location clearance dimensions are as shown in Figure 10-21.

10 - INSTALLATION - Vent and combustion air

CAUTION!!! DO NOT use field-supplied couplings to extend pipes. Airflow restriction will occur and may cause intermittent operation.

6. Operate the appliance one (1) heat cycle to ensure combustion air and vent pipes are properly connected to the concentric vent termination connections.

10.12.3 - Multiventing sidewall terminations

When two or more direct vent appliances are vented near each other, each appliance must be individually vented and vent terminations may be installed as shown in Figure 10-22. It is important that vent terminations be made as shown to avoid recirculation of flue gas.

WARNING!!! Do not connect any other appliance to the vent pipe or multiple boilers to a common vent pipe. Failure to comply could result in severe personal injury, death, or substantial property damage.

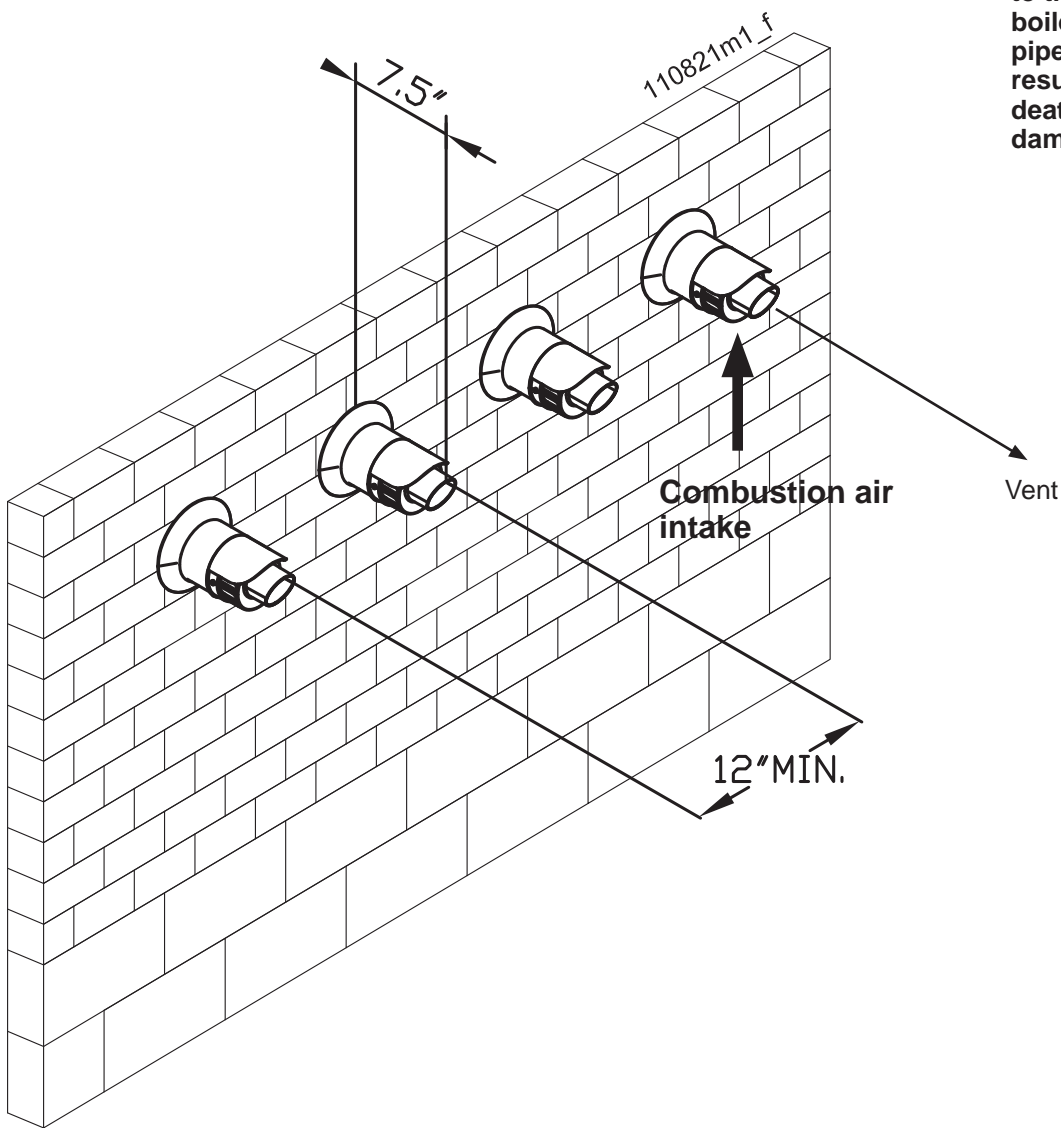

NOTE: keep the terminals horizontally in the same line and at min. 12" from grade or snow line.

Figure 10-22 Concentric sidewall multiple boilers terminations

10 - INSTALLATION - Vent and combustion air

10.13 - Vertical termination - Two pipes

! WARNING!!! Follow instructions below when determining vent location to avoid possibility of severe personal injury, death or substantial property damage.

! WARNING!!! Do not connect any other appliance to the vent pipe or multiple boilers to a common vent pipe. Failure to comply could result in severe personal injury, death, or substantial property damage.

Installation must comply with local requirements and with the National Fuel Gas Code, ANSI Z223.1 for U.S. installations or CSA B149.1 for Canadian installations.

10.13.1 - Determine location

Locate the vent/air terminations using the following guidelines:

1. The total length of piping for vent or air must not exceed the limits given in the Section 10-4.
2. The vent must terminate at least 3 feet above the highest place in which the vent penetrates the roof and at least 2 feet above any part of a building within 10 horizontal feet.
3. The air piping must terminate in a down-turned 180° return pipe no further than 2 feet from the center of the vent pipe. This placement avoids recirculation of flue products into the combustion air stream.
4. The vent piping must terminate at least 1 foot above the air intake. The air inlet pipe and vent pipe can be located in any desired position on the roof, but must always be no further than 2 feet apart and with the vent termination at least 1 foot above the air intake.
5. Locate terminations so they are not likely to be damaged by foreign objects, such as stones or balls, or subject to buildup of leaves or sediment.

10.13.2 - Prepare roof penetrations

1. Air pipe penetration: cut a hole for the air pipe. Size the air pipe hole as close as desired to the air pipe outside diameter.
2. Vent pipe penetration:
 - a. Cut a hole for the vent pipe. For either combustible or noncombustible construction, size the vent pipe hole with at least a 1/2 inch clearance around the vent pipe outer diameter: 4 inch hole for 3 inch vent pipe
 - b. Insert a galvanized metal thimble in the vent pipe hole.
3. Space the air and vent holes to provide the minimum spacing shown in Figure 10-23 and listed in section 10.13.1.
4. Follow all local codes for isolation of vent pipe when passing through floors, ceilings, and roofs.
5. Provide flashing and sealing boots sized for the vent pipe and air pipe.

10.13.3 - Termination and fittings

1. Prepare the vent termination and the air termination elbow (Figure 10-23) by inserting bird screens.
2. The air piping must terminate in a down-turned 180° return bend as shown in Figure 10-23. Locate the air inlet pipe no further than 2 feet from the center of the vent pipe. This placement avoids recirculation of flue products into the combustion air stream.
3. Maintain the required dimensions of the finished termination piping as shown in Figure 10-23.
4. Do not extend exposed vent pipe outside of building more than shown in Figure 10-23. Condensate could freeze and block vent pipe.

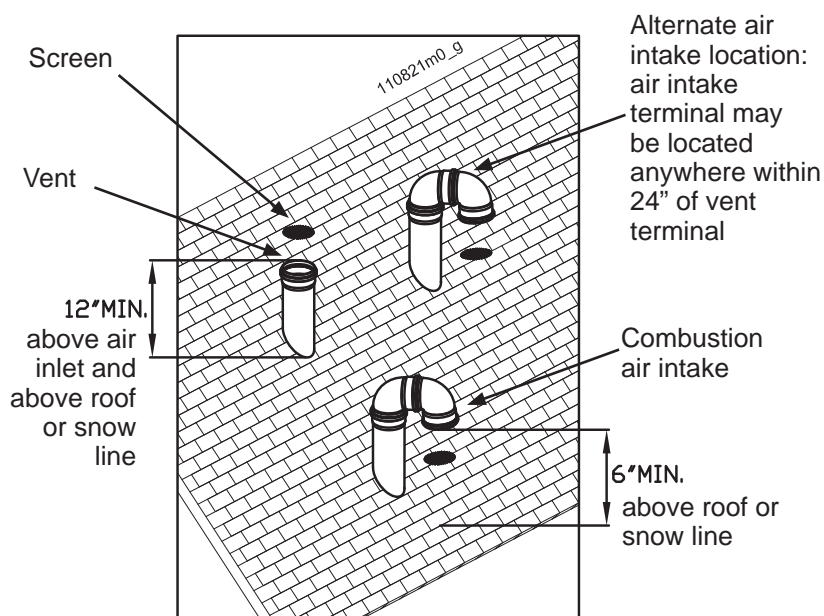

Figure 10-23 Two pipes vertical terminations of air and vent

10 - INSTALLATION - Vent and combustion air

10.13.4 - Multiple vent/air terminations

1. When terminating multiple boilers, terminate each vent/air connection as shown in Figures 10-24 and 10-25.

! WARNING!!! Terminate all vent pipes at the same height and all air pipes at the same height to avoid possibility of severe personal injury, death, or substantial property damage.

2. Place roof penetrations to obtain minimum clearance of 12 inches between edge of air intake elbow and adjacent vent pipe of another boiler for U.S. installations (see Figure 10-24). For Canadian installations, provide clearances required by CSA B149.1 Installation Code.
3. The air inlet is part of a direct vent connection. It is not classified as a forced air intake with regard to spacing from adjacent boiler vents.

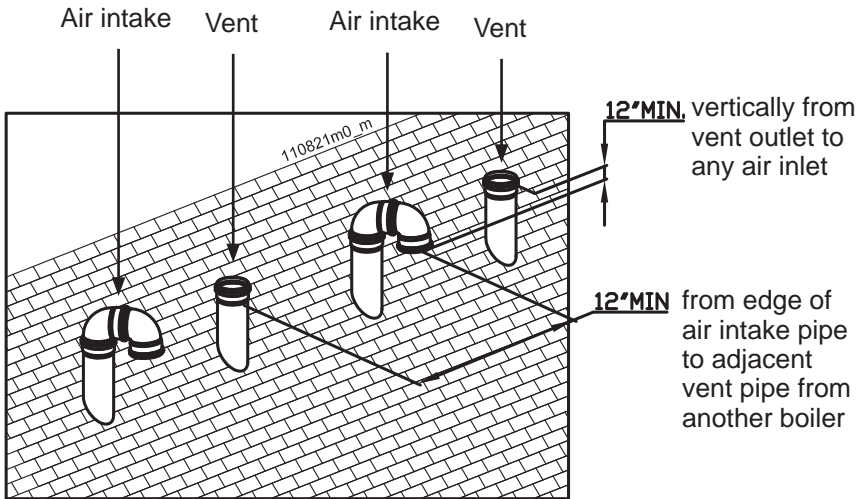

NOTE: keep the terminals at min. 12" from grade or snow line. Provide vent and air intake with bird screen.

Figure 10-24 Two pipes Multiple boilers vertical terminations

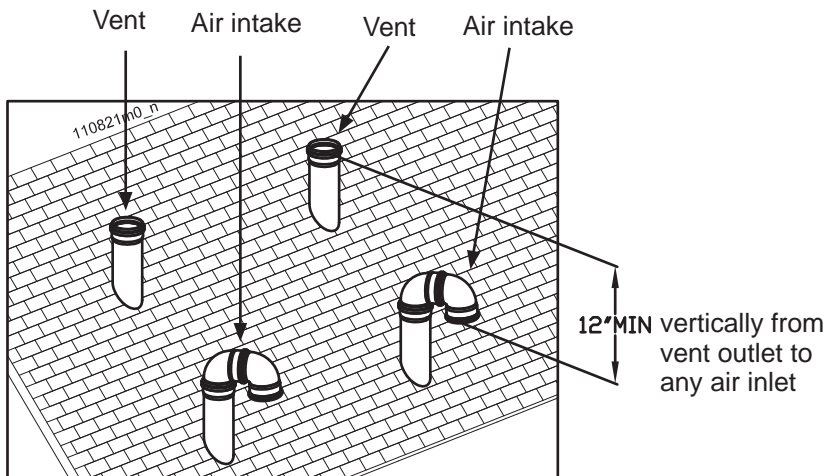

NOTE: keep the terminals at min. 12" from grade or snow line. Provide vent and air intake with bird screen.

Figure 10-25 Alternate vertical terminations with multiple boilers

10 - INSTALLATION - Vent and combustion air

10.14 - Vertical termination – Concentric vent

10.14.1 - Description and usage

Both combustion air and vent pipes must attach to the termination kit. The termination kit must terminate outside the structure and must be installed as shown in Figure 10-26.

10.14.2 - Determine location

Locate the vent/air terminations using the following guidelines:

1. The total length of piping for vent or air must not exceed the limits given in Section 10-4.
2. The concentric terminal must terminate at least 3 feet above the highest place in which the vent penetrates the roof and at least 2 feet above any part of a building within 10 horizontal feet.
3. Locate termination so it is not likely to be damaged by foreign objects, such as stones or balls, or subject to buildup of leaves or sediment.

10.14.3 - Vertical termination installation

1. Determine the best location for the termination kit (see Figure 10-26).
2. The total length of piping for vent or air must not exceed the limits given in Section 10-4.
3. You must consider the surroundings when terminating the vent and air:
 - a. Position the vent termination where vapors will not damage nearby shrubs, plants or air conditioning equipment or be objectionable.
 - b. The flue products will form a noticeable plume as they condense in cold air. Avoid areas where the plume could obstruct window views.
 - c. Prevailing winds could cause freezing of condensate and water/ice buildup where flue products impinge on building surfaces or plants.
 - d. Avoid possibility of accidental contact of flue products with people or animals
 - e. Do not terminate above any door or window. Condensate can freeze, causing ice formations.
 - f. Locate or guard vent to prevent condensate damage to exterior finishes.

4. Cut one (1) hole 6 inch diameter into the structure to install the termination kit.
5. Install the Concentric vent kit following the concentric vent kit manufacturer's instruction.

NOTICE Ensure termination location clearance dimensions are as shown in Figure 10-26.

NOTICE Ensure termination height is above the roof surface or anticipated snow level (12 inches in U.S.A. or 18 inches in Canada) as shown in Figures 10-26.

CAUTION!!! DO NOT use field-supplied couplings to extend pipes. Airflow restriction will occur and may cause intermittent operation.

6. Operate the appliance one (1) heat cycle to ensure combustion air and vent pipes are properly connected to the concentric vent termination connections.

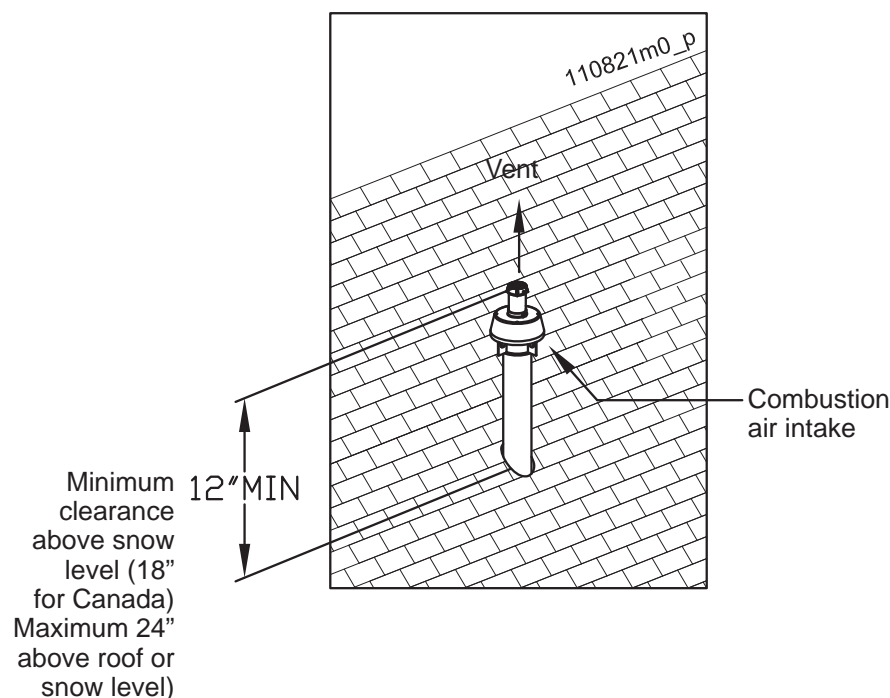

Figure 10-26 Concentric vertical termination

10 - INSTALLATION - Vent and combustion air

10.14.4 - Multiventing vertical terminations

When two (2) or more direct vent appliances are vented near each other, each appliance must be individually vented (see Figure 10-27).

! WARNING!!! NEVER common vent or breach vent this appliance to avoid possibility of severe personal injury, death, or substantial property damage.

When two or more direct vent appliances are vented near each other, two vent terminations may be installed as shown in Figure 10-27. It is important that vent terminations be made as shown to avoid recirculation of flue gases.

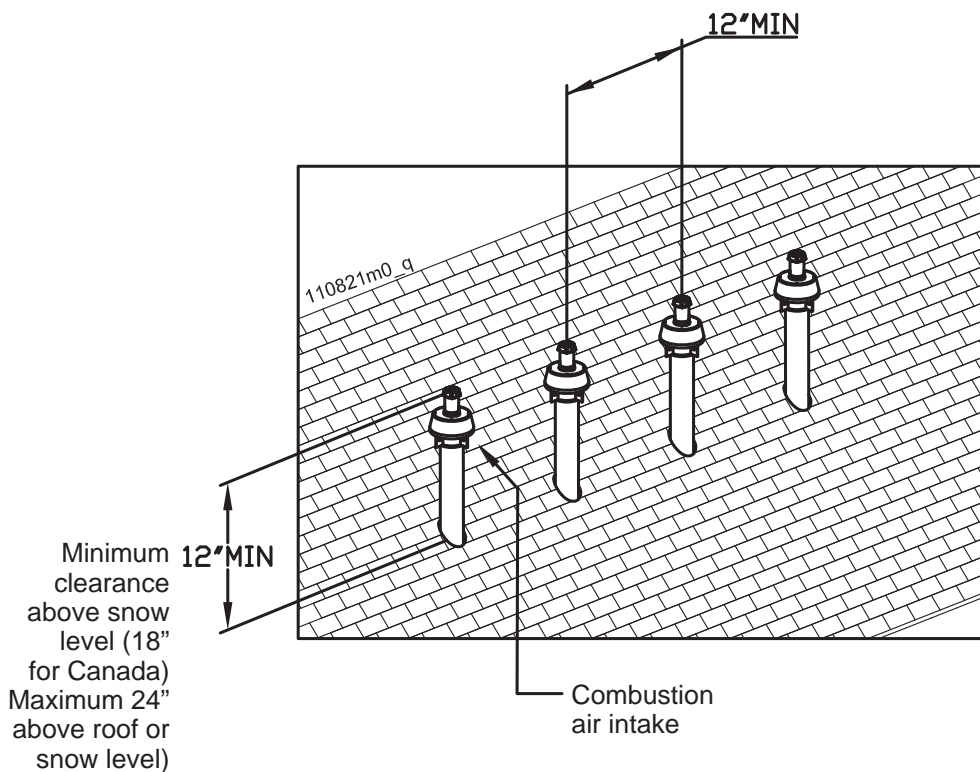

Figure 10-27 Concentric multiple boilers vertical terminations

10 - INSTALLATION - Vent and combustion air

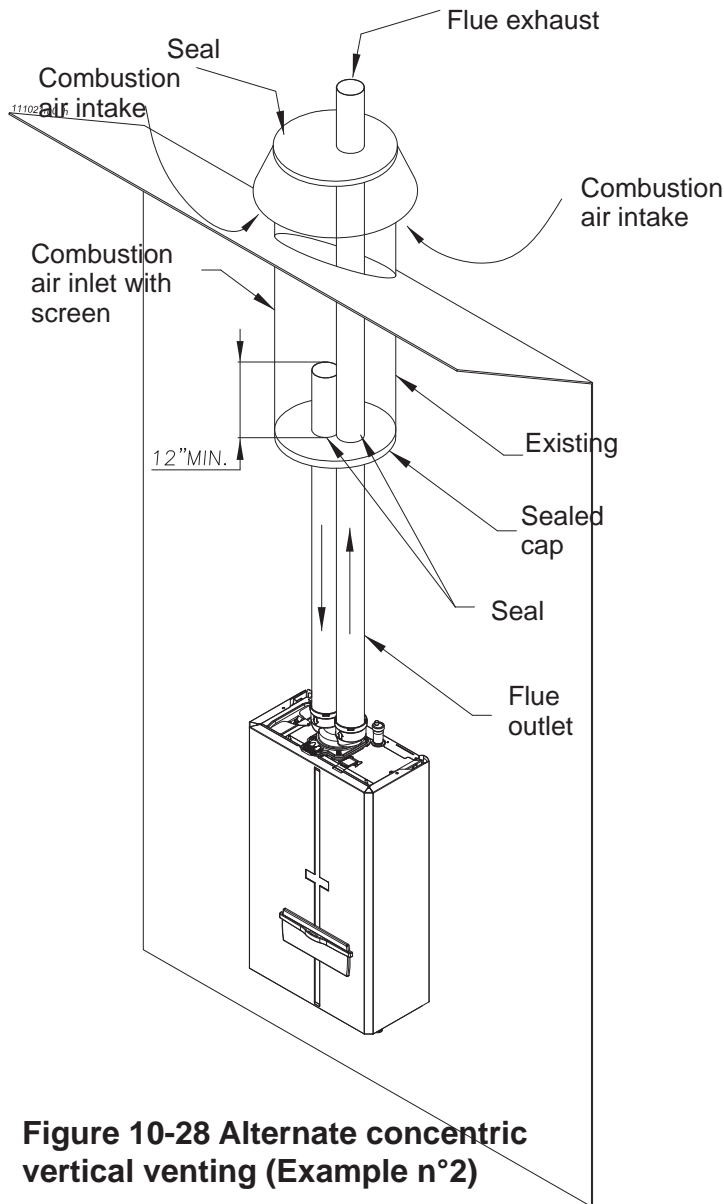

Figure 10-28 Alternate concentric vertical venting (Example n°2)

Approved venting materials must be used as specified in Tables 10-1 and 10-2. Follow all vent / air termination and clearance requirements per this section to the appropriate example. Installation must comply with local requirements and with the National Fuel Gas Code. The maximum allowable equivalent vent and air intake lengths for this venting arrangement are to be determined from Section 10-4. If an existing unused venting system is converted for use with this method of concentric venting, the installer must ensure that the existing venting system is clean and free from particulate contamination that will harm this appliance and cause increased nuisance calls or maintenance. See Section 10.2 for a list of corrosive contaminants and sources. Two example scenarios of a concentric venting arrangement are shown for illustrative purposes in Figures 10-28 and 10-29.

10.14.5 - Alternate vertical concentric venting

This appliance may be installed with a concentric vent arrangement where the vent pipe is routed through an existing unused venting system; or by using the existing unused venting system as a chase for vent and combustion air routing.

Concentric Venting Arrangement

The venting is to be vertical through the roof. The annular space between the O.D. of the vent pipe and the I.D. of the existing unused venting system is utilized for the combustion air source. The minimum size of the existing vent system required to achieve enough annular space for combustion air is 7 inches. The upper and lower termination as well as any other unsealed joints in the existing vent system must be sealed to ensure that all combustion air is drawn from under the vent cap as shown in Figures 10-28 and 10-29.

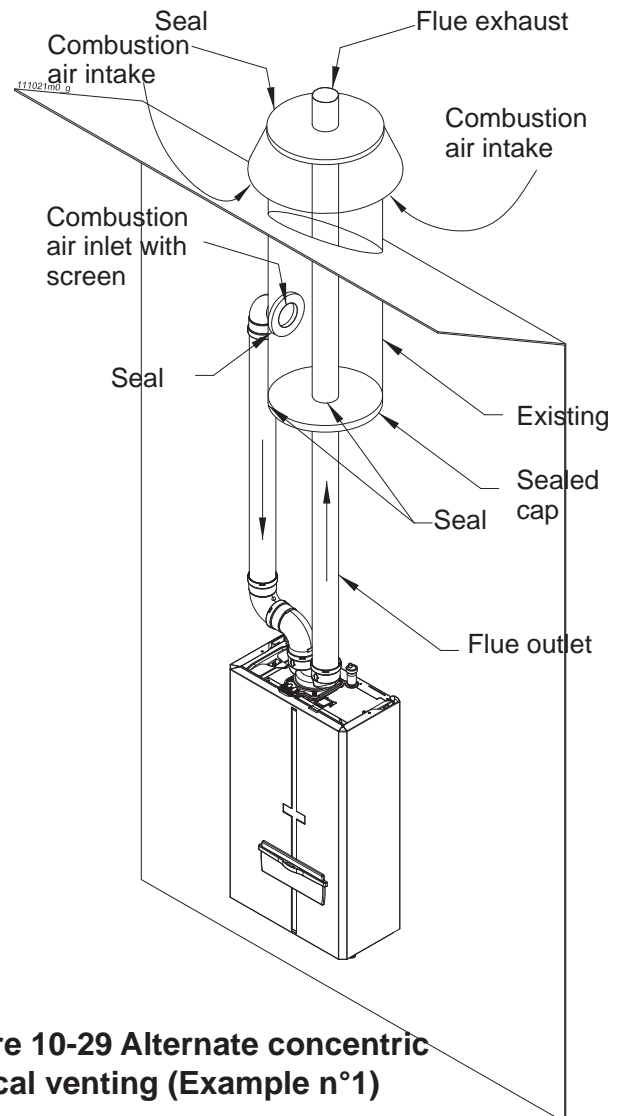

Figure 10-29 Alternate concentric vertical venting (Example n°1)

10 - INSTALLATION - Vent and combustion air

10.15 - Existing vent as a chase

Follow all existing termination and clearance requirements of section 10-13.

The maximum allowable equivalent vent and air intake lengths for this venting arrangement are to be determined from Section 10-4.

Use only approved venting materials listed in Tables 10-1 and 10-2.

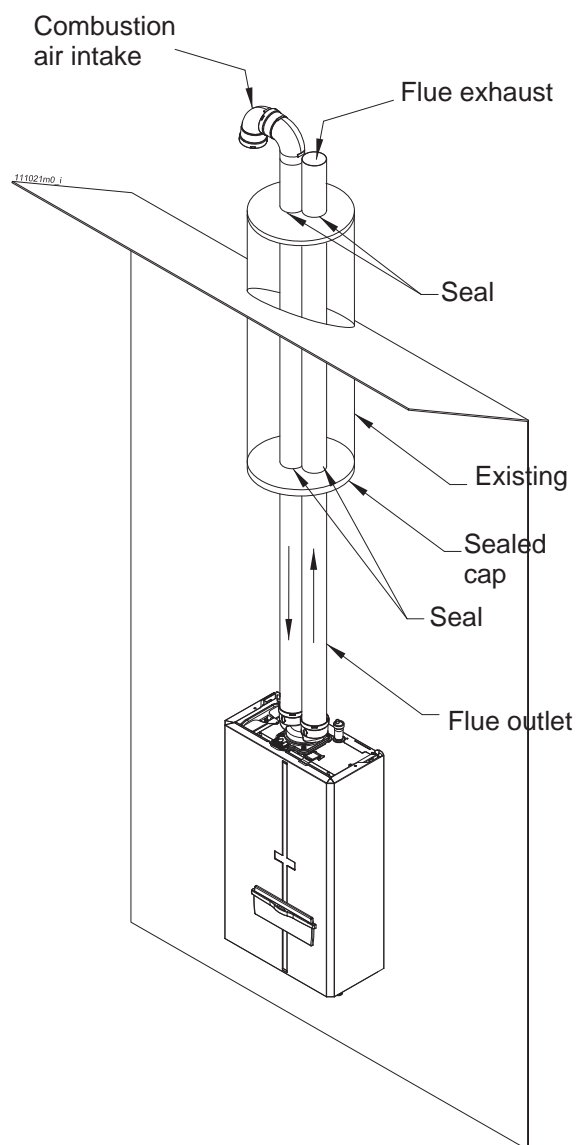

Figure 10-30 Alternate concentric vertical venting (Example n°3)

11 - INSTALLATION - Gas supply

11.1 - Gas supply piping

! WARNING!!! Check that the type and the pressure of the gas supplied correspond with those required for the boiler as stated on the rating plate. Never use a gas different than that stated on the boiler rating plate. Failure to comply with this warning can result in a fire or explosion causing extensive property damage, severe personal injury or death!

Connecting gas supply piping:

1. Refer to Figure 11-1 to pipe gas to the boiler.
 - a. Install ground joint union for servicing, when required.
 - b. Install a manual shutoff valve in the gas supply piping, outside boiler jacket
 - c. Manual main shutoff valves, must be identified by the installer.
2. Install sediment trap / drip leg. (see Figure 11-1).
3. Support piping with hangers, not by the boiler or its accessories.

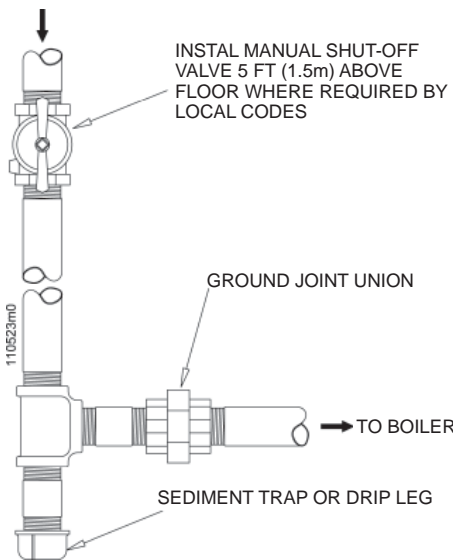

Figure 11-1 Gas supply piping

! WARNING!!! Do not attempt to support the weight of the piping with the boiler or its accessories. Failure to comply could result in severe personal injury, death, or substantial property damage.

4. Purge all air from the gas supply piping.
5. Before placing the boiler in operation, check the boiler and its gas connection for leaks.
 - a. The appliance must be disconnected from the gas

supply piping system during any pressure testing of that system at a test pressure in excess of 1/2 PSIG (3.5 kPa).

- b. The appliance must be isolated from the gas supply piping system by closing a manual shutoff valve during any pressure testing of the gas supply piping system at test pressures equal to or less than 1/2 PSIG (3.5 kPa).
- c. The appliance and its gas connection must be leak tested before placing it in operation.

! WARNING!!! Never use an open flame to test for gas leaks. Always use an approved leak detection method. Failure to comply with this WARNING could result in an explosion!

6. Use pipe sealing compound compatible with propane gas. Apply sparingly only to male threads of the pipe joints so that pipe dope does not block gas flow.

! WARNING!!! Failure to apply pipe sealing compound can result in severe personal injury, death, or substantial property damage.

! WARNING!!! This boiler is typically shipped ready to fire on natural gas. Check boiler rating plate to determine which fuel the boiler is set for. If set to natural gas, it may be converted to LP following instruction on Section 11.6. Failure to comply could result in severe personal injury, death, or substantial property damage.

TABLE 11-1 GAS PIPE CAPACITY

Nominal Iron Pipe Size	Pipe length								
	10'	20'	30'	40'	50'	60'	80'	100'	150'
	Gas Pipe Capacity (ft ³ /hr)								
3/4"	278	190	152	130	115	105	90	79	64
1"	520	350	285	245	215	195	170	150	120
1 1/4"	1050	730	590	500	440	400	350	305	250
1 1/2"	1600	1100	890	760	670	610	530	460	380

Note: Maximum pipe capacity in ft³/hr is based on a 0.60 specific gravity gas at a pressure of 0.5 psig and a 0.3"WC pressure drop

TABLE 11-2 EQUIVALENT PIPE LENGTH CHART

Nominal Iron Pipe Size	Type of Pipe Fitting			
	90°	Tee (branch flow)	Gas Valve (full port)	Gas Cocks
	Equivalent length of pipe fittings in feet			
3/4"	2.06	4.12	0.48	1.25
1"	2.62	5.24	0.61	1.60
1 1/4"	3.45	6.90	0.81	2.15
1 1/2"	4.02	8.04	0.94	2.50

103422m0

11 - INSTALLATION - Gas supply

11.2 - Pipe sizing for natural gas

Refer to Tables 11-1 and 11-2 for pipe length and diameter. Based on rated boiler input (divide by 1,000 to obtain ft³/hr). For additional gas pipe sizing information, refer to ANSI Z223.1 (or B149.1 for Canadian installations).

Natural gas supply pressure requirements

1. Pressure required at the gas valve inlet pressure port:
 - Maximum 13"W.C. with no flow (lockup) or with boiler on.
 - Minimum 3"W.C. with gas flowing (verify during high fire).
2. Install 100% lockup gas pressure regulator in supply line if inlet pressure can exceed 13"W.C. at any time. Adjust lockup regulator for 13"W.C. maximum.

11.3 - Propane Gas

! WARNING!!! These boilers are typically shipped ready to fire on natural gas. Check boiler rating plate to determine which fuel the boiler is set for. If set to natural gas, it may be converted to LP by following instruction on Section 11-6. Failure to comply could result in severe personal injury, death, or substantial property damage.

Pipe sizing for propane gas

Contact gas supplier to size pipes, tanks, and 100% lockup gas pressure regulator.

Propane supply pressure requirements:

1. Adjust propane supply regulator provided by the gas supplier for 13"W.C. maximum pressure.
2. Pressure required at gas valve inlet pressure port:
 - Maximum 13"W.C. with no flow (lockup) or with boiler on.
 - Minimum 3"W.C. with gas flowing (verify during high fire).

! WARNING!!! Ensure that the high gas pressure regulator is at least 6 - 10 ft upstream of the appliance.

11.4 - Check inlet gas supply

! WARNING!!! DO NOT adjust or attempt to measure gas valve outlet pressure. The gas valve is factory-set for the correct outlet pressure. This setting is suitable for natural gas and propane, requiring no field adjustment. Attempting to alter or measure the gas valve outlet pressure could result in damage to the valve, causing potential severe personal injury, death, or substantial property damage.

The gas piping must be sized for the proper flow and length of pipe, to avoid excessive pressure drop. Both the gas meter and the gas regulator must be properly sized for the total gas load. If you experience a pressure drop greater than 1"W.C., the meter, regulator, or gas line is undersized or in need of service.

1. Follow Section 12.7 to check the inlet gas supply pressure.
2. If gas supply pressure is within normal range and no adjustments are needed, proceed on to step 4.
3. If the gas pressure is out of range, contact the gas utility, gas supplier, qualified installer or service agency to determine the necessary steps to provide proper gas pressure to the boiler.
4. Turn the power switch to the "OFF" position.
5. Shut off the gas supply at the manual gas valve in the gas piping to the appliance.
6. After verifying the correct gas pressures disconnect the manometer, turn the screw in pressure connection "D" in Figure 12-3, clockwise until snug and check for any gas leaks.

CAUTION!!! Never force the pressure connection screw or the gas valve will be damaged!

! WARNING!!! Never use an open flame to check for gas leaks, a fire or an explosion could result causing severe personal injury or death!

11.5 - Operating at high altitudes

For installations in the United States, the boiler is rated for operation at altitudes up to 2,000 ft (609 m). For installations at higher altitudes in the United States, follow local codes or, in the absence of local codes, follow ANSI Z223.1/NFPA No. 54, *The National Fuel Gas Code*, and check and adjust the CO₂ level following Section 12-9.

For installations in Canada, the boiler is rated for installations up to 2,000 ft (609 m).

11 - INSTALLATION - Gas supply

11.6 - Convert the boiler from Natural Gas to Propane gas or viceversa

! WARNING!!! The gas conversion shall be performed by a qualified service agency in accordance with this instructions and all applicable codes and requirements of the authority having jurisdiction. The information in these instructions must be followed to minimize the risk of fire or explosion or to prevent property damage, personal injury or death. The qualified service agency is responsible for the proper conversion of the boiler. The installation is not proper and complete until the operation of the converted appliance is checked as specified in this instructions.

! WARNING!!! The conversion shall be carried out in accordance with the requirements of the provincial authorities having jurisdiction and in accordance with the requirements of the CAN-B149.1 and CAN1-B149.2 installation code.

Contents:
The conversion kit (supplied with the boiler) is composed of the following elements, which are necessary for the gas change:
- a label rating the new gas setting;

- an instruction sheet;
- an orifice;

Installing:
in order to make the gas change please follow the instructions below:

- 1 - turn off power to the boiler;
- 2 - open the boiler's casing (Follow Section 14.2);
- 3 - open the instrument panel (Follow Section 9.2);
- 4 - Move switch #7 (see Figure 9-2) from OFF position to ON position;
- 5 - turn on power to the boiler;
- 6 - on the boiler's display you'll see **TY** followed by a number;
- 7 - using the push buttons **+** and **-** set the input **TY** to:

- **61** to convert the boiler from **LP GAS to NATURAL GAS**
- or
- **62** to convert the boiler from **NATURAL GAS to LP GAS**,

- 8 - push **Reset** button to save the new value;
- 9 - turn off power to the boiler;
- 10 - Move switch #7 (see Figure 9-2) from ON position to OFF position;
- 11 - Replace the orifice item "C" of Figure 11-2 for the correct one for the type of gas used. Verify that the

stamping on the orifice matches the gas type (See Table 11-3).

- 11 - turn on power to the boiler;
- 12 - Turn completely counter clockwise the screw E of Figure 11-2;
- 13 - Checking gas supply pressure following Section 12.7. The Gas supply pressure must be between the maximum and minimum value as stated in Table 11-3.
- 14 - Verifying the CO₂ rate and its eventual adjustment following Section 12-9: The boiler during its normal operation, within a maximum altitude of 2000 ft, has a CO₂ exhaust rate as shown in Table 11-3. If not within range of value shown, malfunctions will occur.

! WARNING!!! The CO (carbon monoxide) level should not exceed values given in Table 11-3, when combustion is correct. Failure to comply with this requirement could result in severe personal injury, death or substantial property damage.

! WARNING!!! All combustion measurements must be performed with calibrated equipment to ensure proper reading and accuracy. Failure to comply with this requirement could result in severe personal injury, death or substantial property damage.

Gas Type	TY value setting	Min. supply pressure	Max. supply pressure	Orifice	CO ₂ content at high fire	CO ₂ content at low fire	O ₂ content at high fire	O ₂ content at low fire	CO content at high and low fire
/	/	in.W.C.	in.W.C.	Stamping	%	%	%	%	ppm
Natural gas	61	3	13	9.1	9.2 ± 0.1	8.7 ± 0.3	4.5 ± 0.1	5.4 ± 0.3	less than 150
LP gas	62	3	13	5.7	9.5 ± 0.2	9.5 ± 0.3	6.4 ± 0.2	6.4 ± 0.3	less than 250

Table 11-3 Settings of the boiler for NATURAL GAS and LP GAS

11 - INSTALLATION - Gas supply

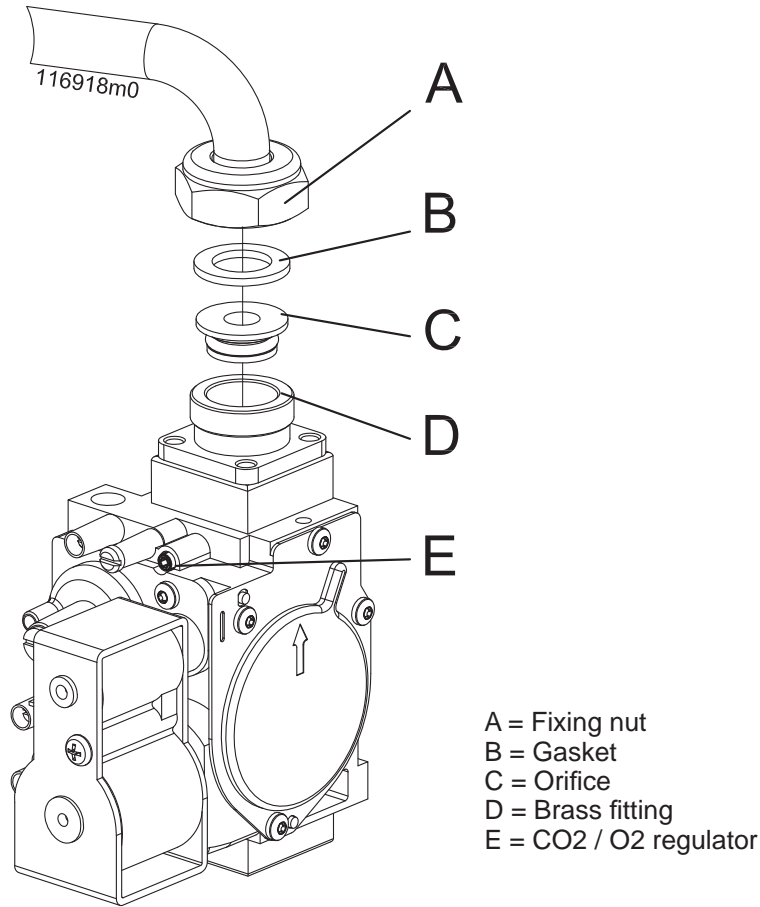

- A = Fixing nut
- B = Gasket
- C = Orifice
- D = Brass fitting
- E = CO₂ / O₂ regulator

Figure 11-2 Gas valve

! WARNING!!! If the combustion levels are not within the range given in Table 11-3 for the firing rate, shut the boiler down and contact your distributor or the boiler manufacturer (see reference in the last cover page). Failure to comply with this requirement could result in severe personal injury, death or substantial property damage.

15 - Attach to the front of the boiler the appropriate conversion label, found in the conversion kit (see Figure 11-3 or Figure 11-4), stating the new type of gas adjustment of the boiler.

- a - Apply the label in Figure 11-4 if the boiler has been converted to **LP GAS**;
- b - Apply the label in Figure 11-3 if the boiler has been converted to **NATURAL GAS**.

ATTENTION!!!

This heater has been converted for use with **NATURAL GAS**

- Maximum inlet gas pressure: 13 In.W.C.
- Minimum inlet gas pressure: 3 In.W.C.
- Manifold pressure: (see rating plate)
- Input rating: (see rating plate)

This water heater was converted on (day-month-year) _____ to _____ gas with kit n° _____ by _____

(name and address of organization making this conversion, who accepts the responsibility for the correctness of this conversion).

62408125.r01

Figure 11-3 Label for Natural gas boiler

ATTENTION!!!

This heater has been converted for use with **LP GAS**

- Maximum inlet gas pressure: 13 In.W.C.
- Minimum inlet gas pressure: 3 In.W.C.
- Manifold pressure: (see rating plate)
- Input rating: (see rating plate)

This water heater was converted on (day-month-year) _____ to _____ gas with kit n° _____ by _____

(name and address of organization making this conversion, who accepts the responsibility for the correctness of this conversion).

62408139.r01

Figure 11-4 Label for LP gas boiler

12 - START-UP

12.1 - Operating

Before starting the boiler, the following must be done.

12.1.1 - User instructions

The user must be correctly instructed by the installer, on how to operate the boiler, in particular:

- ☞ Make sure that the user understands that combustion air and ventilation openings must not be restricted/closed/ or modified in any way.
- ☞ Make sure that the user is informed of all the special measures to be taken for combustion air inlet and discharging flue gases, and that these must not be modified in any way.
- ☞ Make sure that the user keeps this manual and all other documentation included with the boiler.

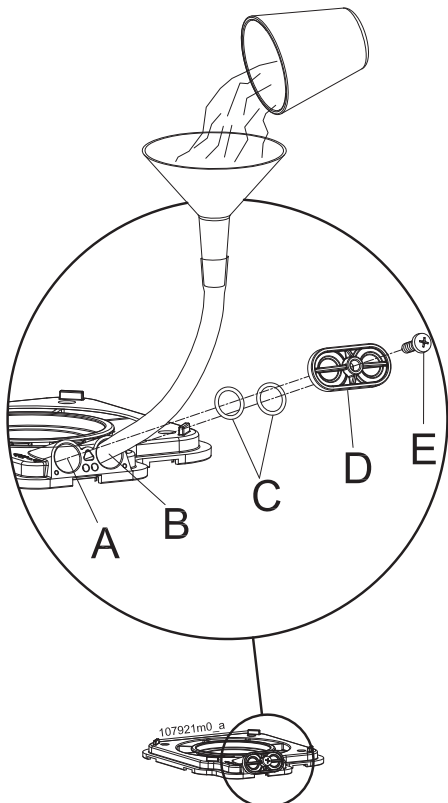

- A = Combustion air probe
- B = Flue exhaust probe
- C = Gaskets
- D = Probe cap
- E = Screw

Figure 12-1 Filling the condensate trap

☞ Make sure that the user understands never to tamper with gas control settings and the risk of CO poisoning should an unauthorized individual do so.

☞ Make sure that the user knows how to adjust temperatures, controls and the room thermostats for maximum efficiency.

12.1.2 - Filling the condensate trap

The condensate trap is positioned inside the boiler as shown in Figure 3-1, item "46". It must be filled with water to prevent the leakage of flue gases from the condensate drainpipe, item "41" in Figure 3-1. To fill the condensate trap proceed as follows:

1. unscrew "E" screw (Figure 12-1);
2. remove flange "D" and O-Rings "C" (Figure 12-1);

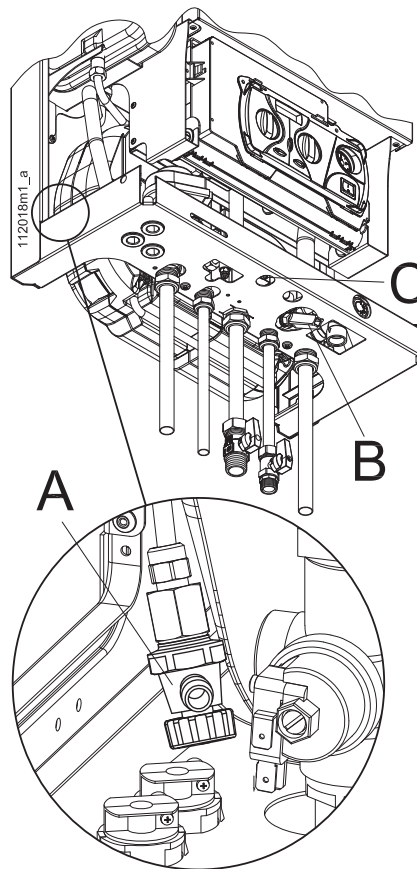

- A = Purging valve for the domestic hot water heat exchanger

Figure 12-2 Domestic heat exchanger

3. With a rubber tube and a funnel, slowly pour approximately 4 oz. (100 ml), of water into the "B" opening - DO NOT put water into the "A" opening (Figure 12-1);
4. re-install flange "D" and O-Rings "C" and reinstall screw "E" (Figure 12-1);

! WARNING!!! If boiler stays off for more than 3 months, repeat the above operation to again fill the condensate trap. Failure to comply with this requirement could result in severe personal injury, death or substantial property damage.

12.1.3 - Filling the heating system

! WARNING!!! Never use non-approved additives or toxic boiler treatment chemicals in the heating system as they can cause serious health problems or possibly death. Any additives introduced into the heating system must be recognized as safe by the United States Food and Drug Administration.

CAUTION!!! The heating system must be filled with clean water from the domestic water system. Contaminated water can damage the boiler voiding its warranty.

CAUTION!!! The addition of any chemical substances, such as anti-freeze, must be carried out according to the product instructions.

To fill the heating system, proceed as follows:

1. open the automatic air vent, shown as item "1" in Figure 3-1, two turns;
2. open the fill valve located under the boiler and proceed to fill the heating system and boiler until the pressure gauge, item "13" in Figure 13-1, reads 20 psi (1.5 bar) and "FILL" disappears from the display;
3. check that there is no water leaking from the fittings. If there is, the leaks must be eliminated;
4. close the fill valve;
5. check the pressure gauge during the purging process. If the pressure has dropped, re-open the fill valve to bring the pressure back up to 20 psi (1.5 bar).

12.1.4 - Filling the domestic hot water heat exchanger (160-C model only)

Once the heating system has been filled and purged, the domestic hot water heat exchanger must be filled as follows:

1. connect a rubber tube to the air purging cock "A" shown in Figure 12-2 and place the end in an empty bucket or sink;
2. open the cock "A" shown in Figure 12-2 until air can be heard escaping;
3. once the water runs clear of air bubbles close the cock "A" shown in Figure 12-2;
4. remove the tube and check that there are no water leaks.

12.1.5 – Auto-purging the heating system

Each time the on/off power switch, item "12" in Figure 13-1, is switched on, an auto-purging cycle lasting 3 minutes begins. The auto-purging process involves the turning the pump on and off in order to remove any air trapped in the heating system. Before starting the auto-purging cycle the automatic air vent, item "1" shown in Figure 3-1 must be opened.

12.1.6 – Delay to light-on

Each time the on/off power switch, item "12" in Figure 13-1, is switched on, a delay timing sequence of 3 minutes begin.

12 - START-UP

12.2 - General warnings concerning gas supply

When starting up the boiler for the first time the following must be checked:

- ☞ That the boiler is supplied with the type of fuel that it is configured to use. Read Sections 11.
- ☞ That the gas supply system is provided with all the safety devices and controls required under current national and local codes.
- ☞ That the vent and combustion air terminals are free from any blockages.
- ☞ That the condensate drain tube is properly connected.

WARNING!!!

If you smell gas:

- Do not try to light any appliance.
- Do not touch any electrical switch. Do not use any phone in your building.
- Immediately call your gas supplier from a neighbor's phone. Follow the gas supplier's instructions.
- If you cannot reach your gas supplier, call the fire department.

Failure to follow the above steps can result in a fire or explosion causing property damage, personal injury or loss of life!

12.3 - Confirming the boiler's gas type

The type of gas and the gas supply pressure that the boiler is set up for is listed on the rating label.

The boiler can operate using one of the following two gases:

NATURAL GAS

Maximum supply pressure = 13 in.W.C. (33.0 mbar).
Minimum supply pressure = 3 in.W.C. (7.6 mbar).

LP Gas



Maximum supply pressure = 13 in.W.C. (33.0 mbar).
Minimum supply pressure = 3 in.W.C. (7.6 mbar).

12.4 - Gas type conversion

If the gas available at the installation site is not the type the boiler is configured to use, the boiler must be converted. Special conversion kits are available for this purpose inside the boiler. Follow instruction on Section 11.6.

 **WARNING!!!** Conversion of the boiler to use another type of gas must be carried out by a qualified technician. Improper conversion of the boiler could result in a fire or an explosion causing severe personal injury or death!

12.5 - Start-up of the boiler

1. Open the manual gas shut off valve (Figure 11-1).
2. Switch the on/off power switch, item "12" in Figure 13-1, to "on".
3. Upon start-up, an **F** is shown for 3 minutes while the boiler goes through its heating system purge cycle. To by-pass this stage, press the  and  keys together until a blinking **F** appears. Then press the  button.
4. Rotate knobs "7" and "11" shown in Figure 13-1 to the desired temperature.
5. The boiler will fire only when the room thermostat calls for heat. If an external temperature sensor is connected, check that the temperature calculated is higher than the minimum running temperature as explained in Section 13.10.
6. If the pump indicator is illuminated, item "6" in Figure 13-1, but the pump is not running, it may be stuck. If this is the case, shut-off the boiler and release the pump.

7. If the pump indicator is illuminated but the heating system does not heat up, repeat the air purging operations on both the boiler and the heating system.

12.6 - Ignition control testing

After placing the boiler in operation, the ignition control's safety shutoff function must be tested as follow:

1. turn the power switch (item "12" in Figure 13-1) to on;
2. close the room thermostat to create a call for heat;
3. turn knobs "7" and "11" in Figure 13-1 to their maximum position;
4. wait a few minutes for the burner to light-up as indicated when light "3" shown in Figure 13-1 stays illuminated.
5. close the manual gas shutoff valve, see Figure 11-1;
6. after 2 minutes, the display must show L01;
7. open the manual gas shutoff valve, see Figure 11-1;
8. verify your gas meter, gas flow must be zero.

 **WARNING!!!** If gas flow occurs, close the manual gas shutoff valve and troubleshoot the system to determine why there is gas flow when the gas valve should be deenergized. Do not operate the boiler until the problem is resolved or a fire or explosion causing property damage, personal injury or loss of life may occur!

12.7 - Gas supply pressure checking

! WARNING!!! DO NOT

adjust or attempt to measure gas valve outlet pressure. The gas valve is factory-set for the correct outlet pressure. This setting is suitable for natural gas and propane, requiring no field adjustment. Attempting to alter or measure the gas valve outlet pressure could result in damage to the valve, causing potential severe personal injury, death, or substantial property damage.

! WARNING!!! DO NOT

adjust the screws "E" and/or "F" (Figure 12-3). These screws are factory-set for the correct gas flow and outlet pressure. Attempting to alter the gas valve setting could result in damage to the valve, causing potential severe personal injury, death, or substantial property damage.

After verifying the correct gas pressures:

1. close the manual gas shut-off valve, Figure 11-1;
2. disconnect the manometer;
3. turn the screw in pressure connection "D" in Figure 12-3, clockwise until snug;
4. check for any gas leaks.

CAUTION!!! Never force the pressure connection screw or the gas valve will be damaged!

! WARNING!!! Never use an open flame to check for gas leaks, a fire or an explosion could result causing severe personal injury or death!

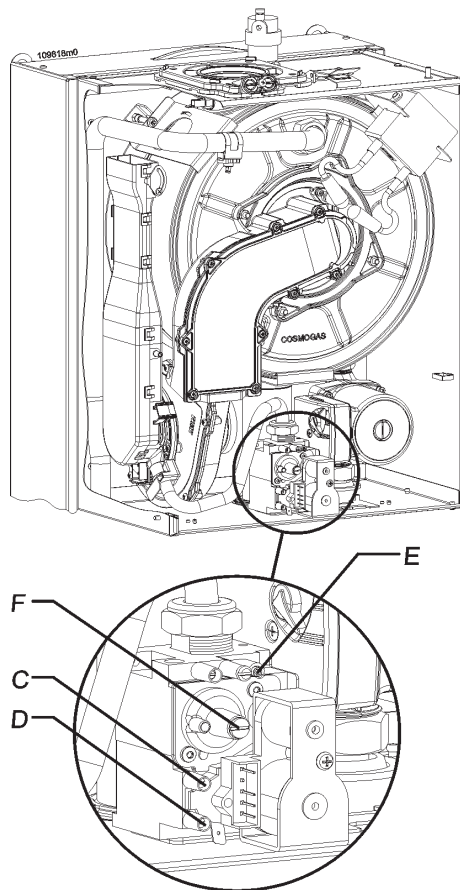

- C - Service pressure probe
- D - Inlet gas pressure probe
- E - CO2 adjusting screw
- F - Factory adjusted regulator (Should never be touched)

Figure 12-3 Gas valve

Check the gas supply pressure by following the steps below:

1. close the manual gas shut-off valve, Figure 11-1;
2. follow the steps in Section 14.2 to remove the front cover;
3. turn the screw in pressure port "D" shown in Figure 12-3 three turns counterclockwise;
4. connect a manometer with graduations of at least 0.1 in.W.C. (0.25 mbar) to the inlet gas port "D" shown in Figure 12-3;
5. open the manual gas shut off valve, Figure 11-1;
6. check that the gas supply pressure does not exceed 13 in.W.C.;
7. turn the power switch to on and generate a heat demand by turning knob "7" shown in Figure 13-1 to its maximum setting. Also ensure that the room thermostat is calling for heat;

8. press the **+** and **-** keys at the same time for more than 10 seconds, the display will show **F⁻** ;

9. press the **+** key until the display shows **t** . Now the boiler will run for 10 minutes at maximum input;
10. check the manometer to make sure the gas supply pressure does not drop below 3 in.W.C. (7.6 mbar).

If the gas supply pressure does not fall within 3 and 13 in.W.C. adjust the

12 - START-UP

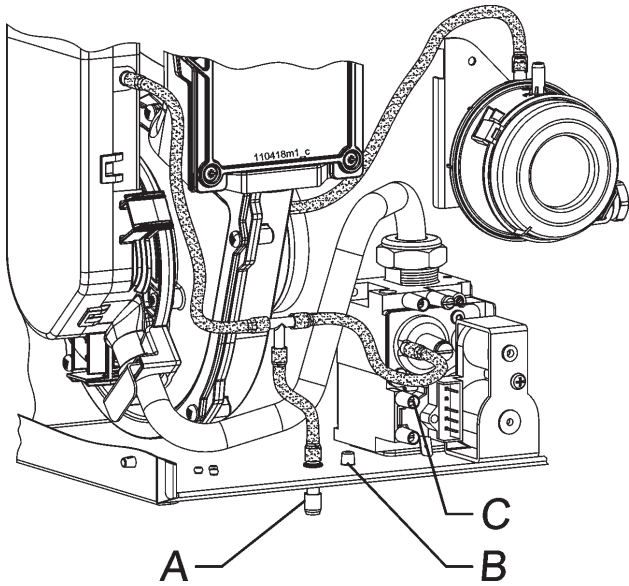

Figure 12-4 Combustion air pressure probes

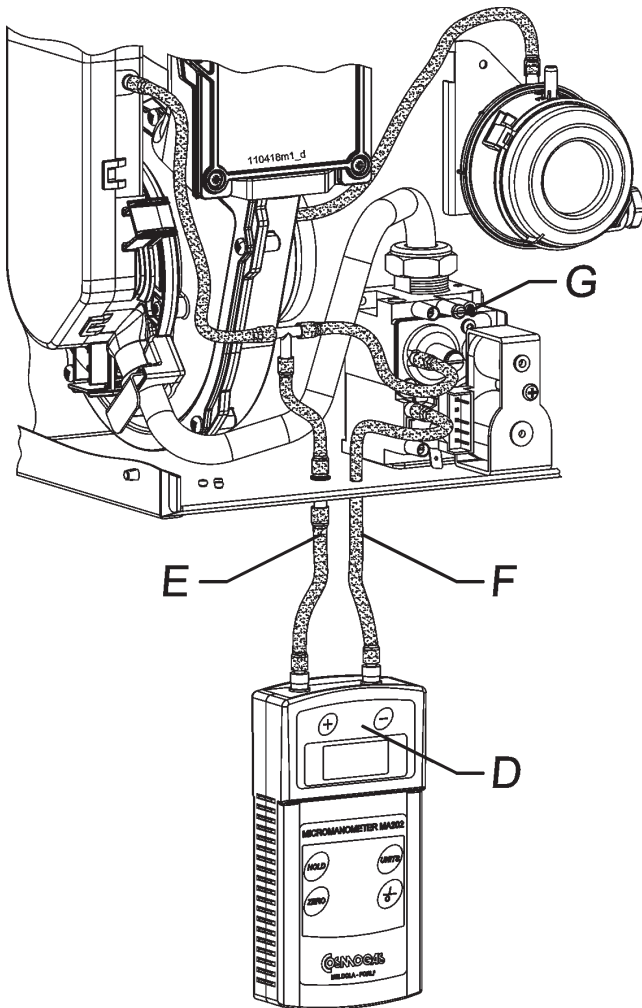

Figure 12-5 Differential pressure gauge connections to checking the combustion air pressure

12.8 - Check the combustion air pressure

The boiler has a factory-set air/gas ratio. The pressure of the gas at the burner is indirectly controlled by the blower. The combustion air pressure must be checked as follows while referring to Figures 12-4 and 12-5:

1. use a differential manometer with a precision of at least 0.1 in.W.C. (0.25 mbar);
2. close the manual gas shut off valve, Figure 11-1;
4. open the boiler casing following Section 14.2;
5. remove plug "B";
6. turn pressure probe screw "C" one turn counterclockwise;
7. insert tube "F", from the negative side of the manometer, through the opening of plug "B", and connect it to pressure probe "C" as shown in Figure 12-5;
8. remove plug "A" from the pressure probe and connect the differential positive side of the manometer to it;
9. the manometer connections must be made as shown in Figure 12-5, to get the correct pressure reading;
10. replace panel "H" of Figure 14-1 and latch it closed. If panel "H" is not properly in place the manometer reading will not be accurate;
11. turn the power switch to on, item "12" in Figure 13-1;
12. press the **+** and **-** keys together for more than 10 seconds, until a blinking **F⁻** is displayed;
13. the combustion blower will run at maximum speed for 10 minutes. During this time the burner will not light;
14. compare the pressure on the manometer with the table in Section 15, row "Combustion air pressure".
15. if the combustion air pressure is too low, check that there are no obstructions in the combustion air and vent systems and check that the flue and air intake length meet with the rules of Section 10.4.;
16. if the combustion air pressure is within tolerance press the **Reset** button to return the boiler to its normal running mode;
17. once the combustion air pressure check has been performed, disconnect the manometer, close pressure probe screw "C", re-install everything like on Figure 12-4. Close the boiler casing and turn the manual gas shut off valve on.

12.9 - Checking and adjusting CO2 levels

Table 11-3 lists the correct CO2 ranges for a boiler running at normal operating conditions at an altitude below 2000 ft (600m). CO2 values outside of the ranges given in Table 11-3 may lead to malfunctioning of the boiler and cause it to prematurely fail. To check the CO2 value, carry out a combustion analysis as follows while referencing Figure 12-6:

! WARNING!!! During this procedure compare also CO (carbon monoxide) reading, with the value given in Table 11-3. If this is higher, STOP the boiler and call the Factory service department (see phone number on the last cover page). Failure to comply with this requirement could result in severe personal injury, death or substantial property damage.

NOTE: During the 10 minutes override mode, if the demand on the boiler is low causing the flue gas temperature to increase rapidly, boiler will go into lock out code L06.

To reactivate it, press **Reset** button.

- carefully remove items "E", "D" and "C" from the combustion air/ vent fitting;
- generate a call for heat; and wait up the boiler is light-on;
- press the **+** and **-** keys for more than 10 seconds, the display will show a blinking **F** ;
- press the **+** key until the display shows **t** if a call for heat has been generated or until **S** is displayed if a domestic hot water demand has been generated. The boiler will now run for 10 minutes at high fire input;
- wait 2 to 3 minutes for the CO2 to stabilize;
- insert the probe of a calibrated combustion analyzer into port "B" and take a flue gas sample;
- compare the CO2 reading with the high fire range given in Table 11-3,

making sure to use the range for the gas type in use. If the CO2 reading is outside the specified range, it must be adjusted operating on the "E" screw of Figure 12-3. Use a 2.5mm Allen Wrench to turn the screw (clockwise to reduce the CO2 level, counter-clockwise to increase the CO2 level) in small increments and wait for the CO2 to stabilize to prevent overshooting the desired value;

- When CO2 level match the value of Table 11-3, seal screw "E" with red paint or nail polish to discourage tampering.
- press the **-** key until the display shows **t** if a call for heat has been generated or until **S** is displayed if a domestic hot water demand has been generated. The boiler will now run for 10 minutes at low fire input;
- wait 2 to 3 minutes for the CO2 to stabilize;
- compare the CO2 reading with the low fire range given in Table 11-3, making sure to use the range for the gas type in use. The CO2 reading must be inside the specified range; If not, STOP the boiler and call the Factory service department (see phone number on the last cover page).
- press the **Reset** button to return the boiler to its normal operating mode.
- close flue and air probe "A" and "B" of Figure 12-6.
- turn knob "7" and "11" of Figure 13-1 to the OFF position.

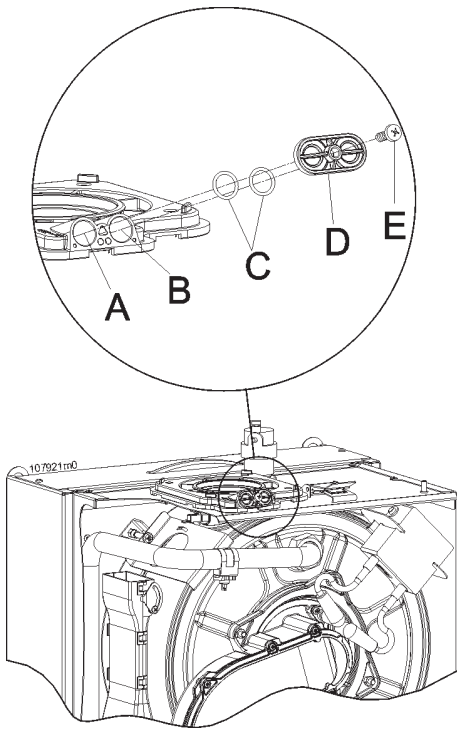

- A = air probe
- B = flue exhaust probe
- C = O-ring gaskets
- D = cap
- E = fixing screw

Figure 12-6 Combustion analysis probes

12.10 - Adjusting the heating capacity

This boiler has been engineered with an “intelligent” micro-processor control that will adjust the heating output to match the system demand. To maximize the effectiveness of

the system, the parameters **P** found in the “Installer’s menu”, in Section 13.17, can be adjusted set the maximum heating output to the effective maximum load necessary

for the system. The **P** parameter can be adjusted from 100 (factory set value), to 1. The correspondence

between **P** value and heating output is given by table in Figure 12-1.

NOTE: This setting, adjusts the heating input only. The domestic output is always 160,000 btu/hr for every **P** value.

12.11 - Domestic hot water flow rate adjustment (160-C model only)

The volume of domestic hot water that the boiler can produce, depends on the flow rate of the domestic water system. If the flow rate is too high, the water will move through the heat exchanger without being adequately heated. It is therefore advisable to carry out the following adjustments:

1. switch the on/off power switch, item “12” in figure 13-1, to “on”;
2. adjust control “11” as shown in Figure 13-1, to 130 °F (50 °C);
3. fully open a hot water faucet. If a mixing type faucet with single lever is opened, the position must be fully to HOT;
4. set the domestic hot water mixing valve (field installed), to its maximum value);
5. wait 5 minutes for the temperature to stabilize;
6. if the water temperature is too low, reduce the water flow using a flow restrictor (Field installed) until reaching the desired temperature (turn the flow restrictor in small increments and wait for the temperature to stabilize to prevent overshooting the desired value).

NOTE: Water flow should generally be regulated according to the values given in Section 15, under the heading “instantaneous d.h.w. production [rise 75 °F (42 °C)]”.

12.12 - Cold start boiler

The boiler has a “cold start” working mode. Any time the room thermostat opens (no call for heat), the burner stops immediately. However even with the room thermostat contact open, the boiler will run for freeze protection as described in Section 13.14.

“P” parameter value	Correspondent heat input (btu/hr)
100	160,000
92	150,000
85	140,000
77	130,000
69	120,000
62	110,000
54	100,000
46	90,000
38	80,000
31	70,000
23	60,000
15	50,000
8	40,000
1	30,000

103122m0_b

Table 12-1 - Correspondence table to set space heating input

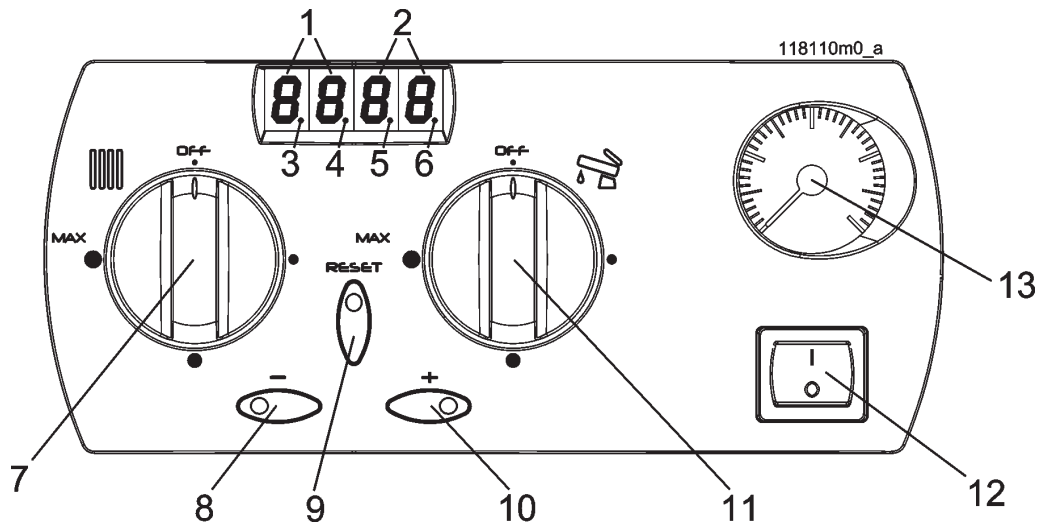

- 1 - Display of the parameters
- 2 - Display of the parameters value.
- 3 - Light indicates the burner state: Light-on = Burner ON; Blinking = Burner OFF.
- 4 - Light indicating DHW service: Light-on = DHW service ON; Light-off = DHW service OFF.
- 5 - Light indicates the decimal.
- 6 - Light indicates CH service: Light-on = CH service in function; Light-off = CH service out of function.
- 7 - Heating temperature control.
- 8 - Key for decreasing parameter values.
- 9 - Key for resetting shutdowns and for scrolling the list of parameters.
- 10 - Key for increasing parameter values.
- 11 - Domestic hot water temperature control.
- 12 - On/off power switch.
- 13 - Heating circuit pressure gauge.

Figure 13-1 Instrument panel

13.1 - Check heating system pressure

If the pressure inside the heating circuit falls below 7psi (0,5 bar), the appliance switches off and the display "1" as per Figure 13-1, shows **FILL** to indicate that it is necessary to restore the correct pressure. Open the filling cock and check the pressure on the pressure gauge "13" of Figure 13-1, it must reach a pressure of 20 psi (1,5 bar) and the indication **FILL** must disappear; close the filling cock.

CAUTION!!! During normal operations, the filling cock must always remain in the closed position.

If, with time, the pressure drops, restore the correct value. This operation may have to be repeated

several times during the first month of operations to remove any air bubbles present.

13.2 - Overview

The boiler is pre-set with standard parameters. However, it is possible to make a number of changes or consult the parameters by means of using the "Users' Menu" (see Section 13.16). During functioning display "1" of Figure 13-1, displays the status of the boiler and display "2" (see Figure 13-1) shows the value of the parameters. The various operating statuses are shown in Section 13.18. Within the "Users' Menu" (see Section 13.16) it is possible to check the last lock-out or error which have occurred. In addition to the operating modes, the instrument panel provides important information on the current functioning of the boiler, via the indicators "3", "4", "5" and "6" of Figure 13-1. In particular:

- the indicator "3" displays whether the burner is functioning (on) or whether it

is off (blinking);
 - the indicator "4" displays whether the domestic hot water service is on or off;
 - the indicator "6" displays whether a heating service request is active (on) or nor (off).

13.3 - Displays

During normal operations, the parameters' display "1" and the values' display "2" (see Figure 13-1) remain permanently on, if the "Energy Saving" mode has not been activated (See Section 13.15). The parameters which can be displayed are shown with their meaning in the table shown in Section 13.18.

13.4 - Start-up procedure

1. Open the manual shutoff gas valve;
2. switch on electric power to the boiler;
3. If the display shows code E21, it means that the polarity has not been observed between phase and neutral (Call service department, do not attempt to repair it);
4. on initial start-up, the appliance carries out a light-on delay lasting 3 minutes. This is indicated by the appearance of **F** on the display;
5. wait 3 minutes until the end of the **F**;
6. turn knob "7" of Figure 13-1 until it reaches the heating temperature desired. Turn knob "11" of Figure 13-1 until it reaches the domestic water temperature desired.

The flame control appliance will start-up the burner.

If the burner fails to ignite within 15 seconds, the boiler will automatically attempt ignition another two times, after which if it fails to start-up, it will shut down and the display will show **L** 01.

Press the **Reset** button in order to re-set normal operating conditions. The boiler will automatically attempt another start-up.

CAUTION!!! If the appliance frequently shuts down, contact a qualified technician to restore normal running conditions.

Now the boiler will continue to operate in relation to the service requested and will indicate the following on display "1":

- **d** if a domestic water request is active (Load of an indirect water heater);
- **C** if a heating request is active;
- **0** if there is no domestic water or heating request active.

13.5 - Summer mode

To disable the heating functions for a prolonged period, leaving only the domestic hot water function, switch OFF the heating temperature, until the wording OFF appears, by turning knob "7" of Figure 13-1 to the minimum.

13.6 - Winter mode

In Winter mode, by means of the pump, the boiler sends the water to the system at the temperature set using knob "7" of Figure 13-1. When the temperature inside the boiler reaches the temperature set, the burner starts to modulate the flame so as to reduce the output to a minimum. If the temperature rises further, the burner shuts down. Simultaneously, the pump which sends the water to the system is switched on and off by the room thermostat. This can be noted, because indicator "6" of Figure 13-1 switches on and off in correspondence with the on and off of the pump. At first the pump may make a noise. This is due to the presence of residual air in the hydraulic system which will soon disappear on its own. We recommend keeping the temperature set using knob "7" at the point shown by the symbols on the panel for a rational use of the boiler. If it is a particularly cold Winter and it is difficult to maintain the desired room temperature, turn knob "7" to gradually higher values.

CAUTION!!! do not demandate the antifreeze protection of your house to the boiler. Because the boiler's function depends from the electrical supply and from the gas supply and because a trouble can stops the boiler, if you live your house, it is mandatory install a safety device that alarm the user in a case the house will reach a temperature near 50°F (10°C).

13 - USE

13.7 - Adjusting the domestic hot water temperature

The domestic hot water temperature is adjusted by turning knob “11” shown in Figure 13-1. When the knob is turned, the display, item “1” in Figure

13-1, shows a flashing **d** and the temperature being selected. The range within which the domestic hot water can be set is 104°F (40°C) to 140°F (60°C) or from 104°F (40°C) to 158°F (70°C) when an indirect storage tank is used.

13.8 - Heating system temperature adjustment

The boiler provides hot water to the heating system at the temperature set by adjusting knob “7” as shown in Figure 13-1. The room thermostat turns the boiler’s circulator pump on in order to satisfy the heat demand of the rooms controlled by the thermostat. To maximize the boilers’ performance, temperature knob “7”, should be set at a value that is just sufficient to maintain the desired temperature of the rooms. As the weather gets colder, progressively increase the water temperature by adjusting knob “7”. When the weather gets milder turn the water temperature down. This extremely simple method is suitable for the following types of systems:

- A - small systems with radiators where the thermostat is installed in a room whose temperature is characteristic of all the other rooms;
- B - large systems with radiators, where each zone is controlled by its own room thermostat. Where zone valves are used the boiler pump is shutdown only when all the room thermostats are satisfied.
- C - large systems with low temperature radiant panels, where each zone is controlled by its own room thermostat. Where zone valves are used the boiler pump is shutdown only when all the room thermostats are satisfied.

13.9 - Heating system type selection

The boiler is factory set for wall stat control as per Section 13.8.

The heating system type can be changed by going to the “Installers’ Menu” in Section 13.17 and changing the **CH** parameter. One of the three following heating modes can be selected:

- CH = 00 “Wall stat control”: follow Section 13.8;
- CH = 01 “Outdoor reset control”: follow Section 13.10 (an outdoor temperature sensor is required);
- CH = 02 “Outdoor reset control with room compensation control”: follow Section 13.10.1 to 13.10.6 (an outdoor temperature sensor is required):

13.10 - Outdoor reset adjustment

While in the “Installers’ Menu”, set the **CH** parameter to 01. In this mode the heating supply water temperature, calculated temperature in Figures 13-2 and 13-3, will be adjusted automatically based on the input from the outdoor temperature sensor. The relationship between the outdoor temperature and the supply water temperature, corresponds with the graphs shown in Figures 13-2 and 13-3. In order to change the relationship between the supply water temperature and the outdoor temperature, all the parameters listed in the sections below must be set.

13.10.1 - Outdoor reset applications

Outdoor reset is a sophisticated way to maximize comfort and boiler efficiency. It is suitable for the following system types:

- A - small systems, with radiators where the thermostat is installed in a room whose temperature is characteristic of all the other rooms. The room thermostat is used to turn the boiler

on and off.

- B - large systems, with radiators, where each zone is controlled by its own room thermostat. Where zone valves are used the boiler pump is shutdown only when all the room thermostats are satisfied (see to an appropriate electrical system).
- C - small systems, with low temperature radiant panels where the thermostat is installed in a room whose temperature is characteristic of all the other rooms. The room thermostat is used to turn the boiler on and off. In this type of system it is necessary to consider that the radiant panel systems sometimes have long lag times.
- D - large systems with low temperature radiant where each zone is controlled by its own room thermostat. Where zone valves are used the boiler pump is shutdown only when all the room thermostats are satisfied.

13.10.2 - Outdoor reset adjustment precautions

When making adjustments to change the supply temperature, it is advisable to first set the suggested default values for the desired curves shown in figures 13-2 and 13-3. If these default values do not produce a satisfactory result, then proceed to make the appropriate adjustments bearing in mind that:

- A - each parameter must be very gradually;
- B - after each parameter change, wait at least 24 hours in order to see the result;
- C - the closer the adjustment curve matches the actual load of the building, the greater the comfort and the energy savings will be;
- D - knob “7” in Figure 13-1 can be used to make the small line shifts, “b”, shown in Figure 13-3. These shifts will change the supply water temperature up to 18 °F (10 °C).

13.10.3 - Outdoor reset: setting parameters

Refer to Section 13.16 and set:

- **0A** = "The angle of the curve", which can be adjusted between 0.1 and 5.0. Suggested starting values are: 0.6 for "low temperature" systems; 1.6 for "high temperature" systems;
- **0b** = "Minimum heating temperature". When the calculated temperature drops below this value the heating service stops. The range of adjustment is between 68 °F (20 °C) and 140 °F (60 °C). The suggested starting values are: 86 °F (30 °C) for "low temperature" systems; 104 °F (40 °C) for "high temperature" systems;
- **0c** = "Maximum heating temperature". This parameter is the high limit of the supply heating temperature. Its range of adjustment is between 86 °F (30 °C) and 194 °F (90 °C). The suggested starting values are: 113 °F (45 °C) for "low temperature" systems or 176 °F (80 °C) for "high temperature" systems.

Refer to Section 13.17 and set:

- **cn** = This parameter must always be at value of 1.
- **br** = "Fix point" is the heating calculated temperature, when the outdoor temperature is 68 °F (20 °C). It is called "Fix Point" because it is also the angle fulcrum of the curve. The suggested starting values are: 92 °F (33 °C) for "low temperature" systems 122 °F (50 °C) for "high temperature" systems.

13.10.4 - Outdoor reset: zone adjustments

The default values previously suggested are for boilers using an outdoor temperature sensor installed in dwellings with average heat loss in areas where the design outside winter temperature is 23 °F (-5°C). In the event that the climatic zone is different, adjust the parameter **0A**, to obtain a calculated temperature of 176 °F (80 °C) for the typical design outside winter temperature, see Figure 13-2.

13.10.5 - Outdoor reset activation

Once selected, reset adjustment is completely automatic and will switch off at the end of the heating season and switch back on at the beginning of the heating season. When the "Calculated temperature" is lower than the "Minimum heating temperature", (parameter **0b**), the heating service switches off. When the "Calculated temperature" exceeds the "Minimum heating temperature" (parameter **0b**), the heating service switches back on. If for some reason the heating service doesn't match the load, use knob "7" in Figure 13-1, to raise or lower the calculated temperature and match the "Minimum heating temperature" on an advanced or delayed basis.