



Gas Conversion Field Assembly Kit

Natural Gas to Liquefied Petroleum (Propane) or
Liquefied Petroleum (Propane) Gas to Natural

Only for use with Slant/Fin boilers equipped with Honeywell VR8200, VR8204, VR8300 and VR8304 gas valves, either standing (continuous burning) pilots or intermittent ignition systems.

WARNING

This conversion kit shall be installed by a qualified service agency in accordance with the manufacturer's instructions and all applicable codes and requirements of the authority having jurisdiction. If the information in these instructions is not followed exactly, a fire, an explosion or production of carbon monoxide may result causing property damage, personal injury or loss of life. The qualified service agency is responsible for the proper installation of this kit. The installation is not proper and complete until the operation of the converted appliance is checked as specified in the manufacturer's instructions supplied with the kit.

WARNING-IMPORTANT

1. This conversion kit is supplied with the same parts normally provided on SLANT/FIN factory built boilers which are Design Certified by CSA International. However, because we have no way of applying our own quality control procedures to field alterations made by others on this boiler, these alterations are not the responsibility of SLANT/FIN. These alterations are the responsibility of the installer of this conversion kit. The instructions below must be carefully followed in order to duplicate factory installation.
2. The installation must conform to the requirements of the authority having jurisdiction or, in the absence of such requirements, to the National Fuel Gas Code ANSI Z223. 1-latest edition.

WARNING

SPECIAL ATTENTION FOR LIQUEFIED PETROLEUM (L.P.) PROPANE GAS-FIRED BOILER INSTALLATIONS

LPG appliances (boilers) shall be installed in accordance with applicable provisions of NFPA 58 (Liquefied Petroleum Gas Code) latest edition for installations in US and CAN/CGA B149.1 latest edition for installations in Canada.

Liquefied Petroleum (LP) propane gas is heavier than air, therefore, propane gas can accumulate at floor level. If you suspect a leak, do not attempt to operate boiler. A spark or flame from the appliance (boiler) or other sources may ignite the accumulated propane gas causing an explosion or fire. It is recommended that inspections for gas leaks be performed periodically by a licensed professional and that leak detection devices be installed as a further safety measure.

The boiler warranty is void unless this field assembly conversion kit has been properly installed, labels completed and applied to boiler and registration card completed and received by Slant/Fin within 10 days after kit has been installed in boiler.

SENTRY SERIES BOILER
 Location and identification of parts.

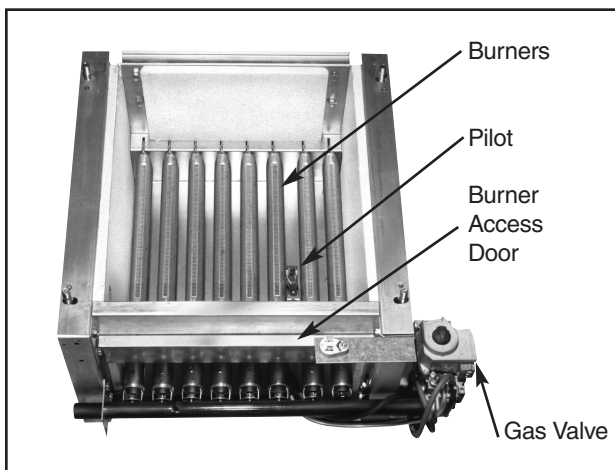
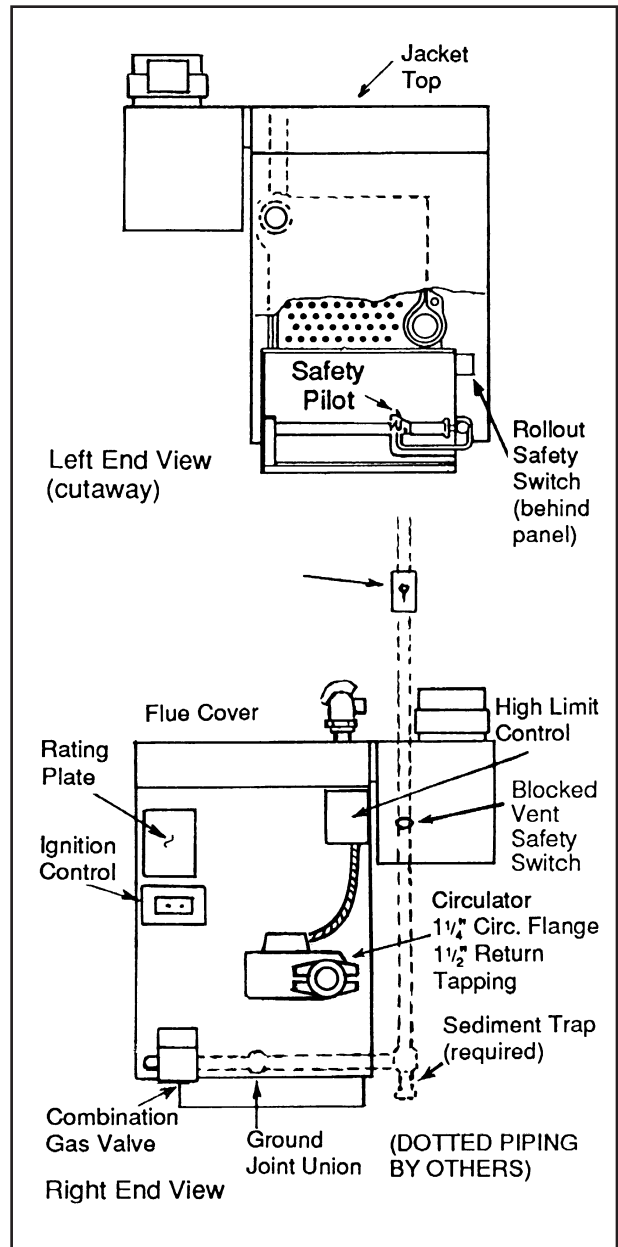
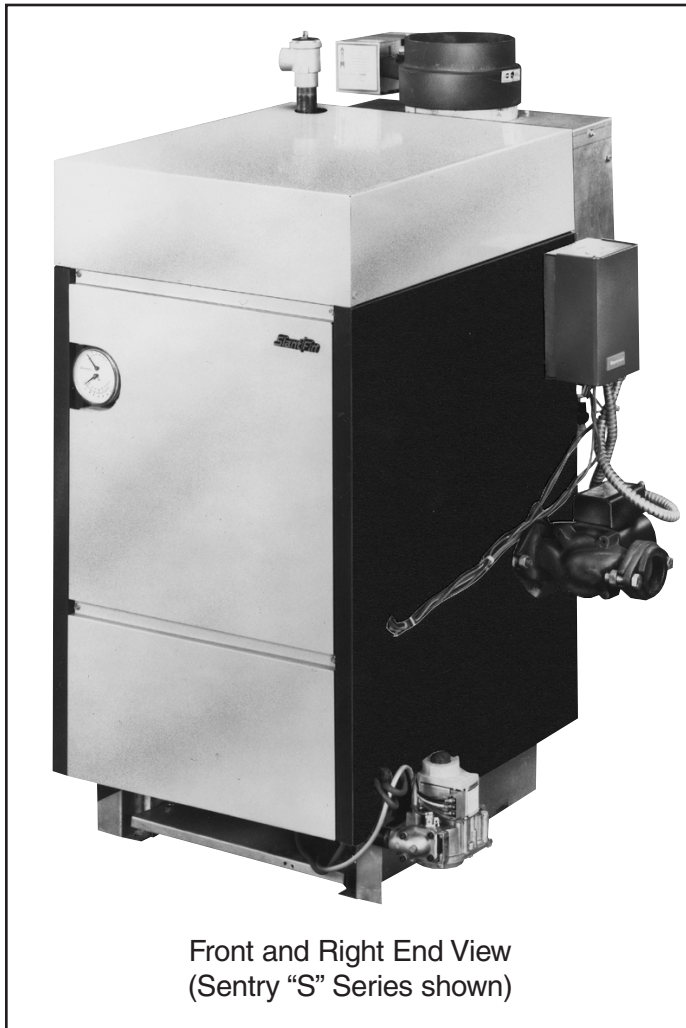

Base Assembly

VICTORY VSP AND VSPH SERIES BOILERS

Location and identification of parts.

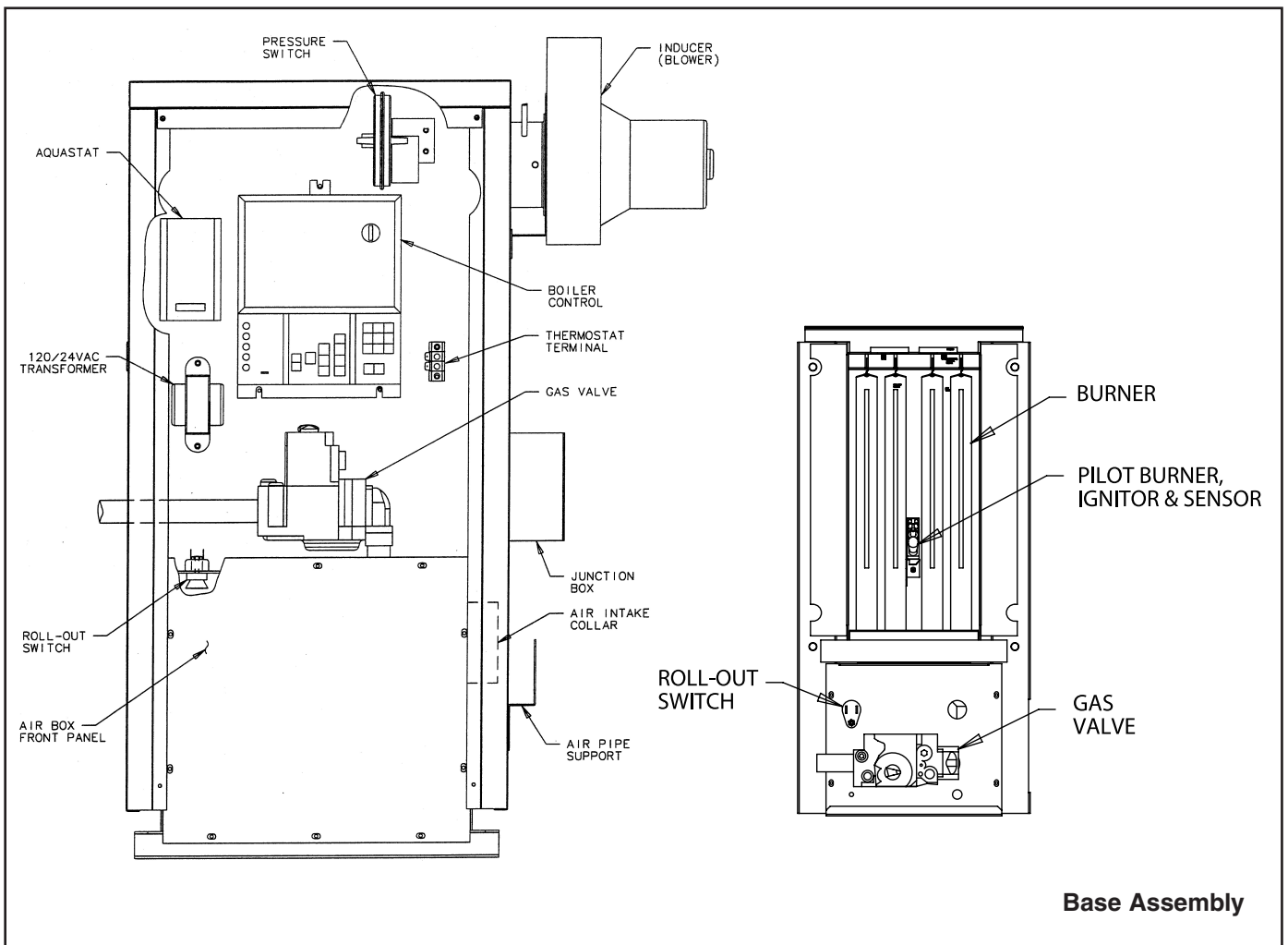

SENTINEL SERIES BOILER
 Location and identification of parts.

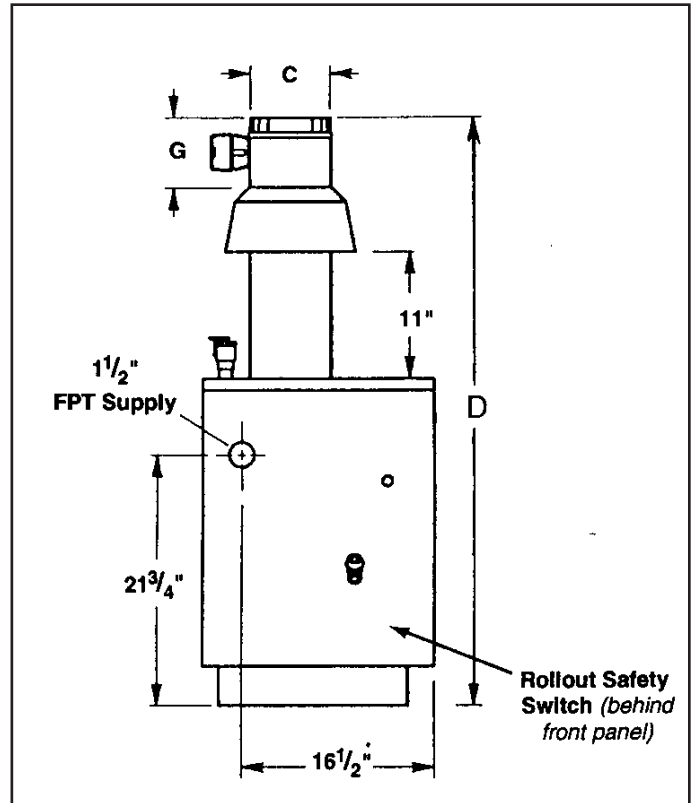

LEFT END VIEW

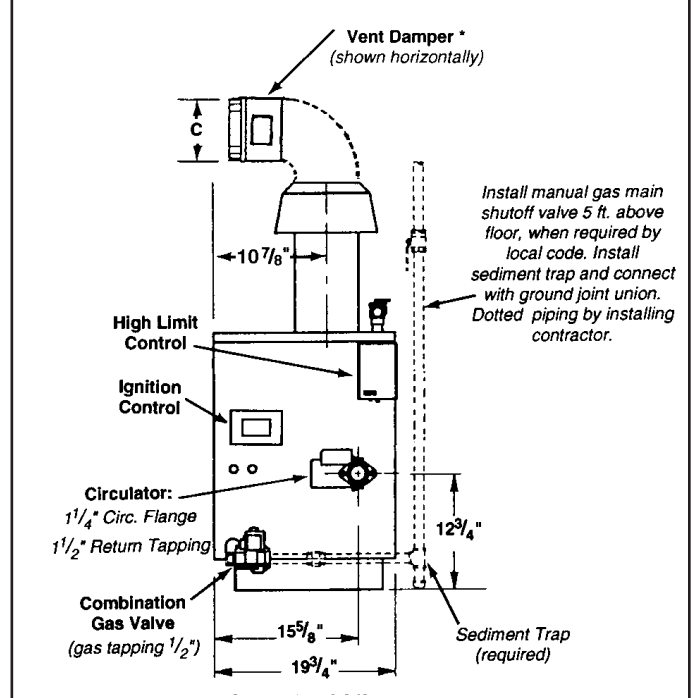
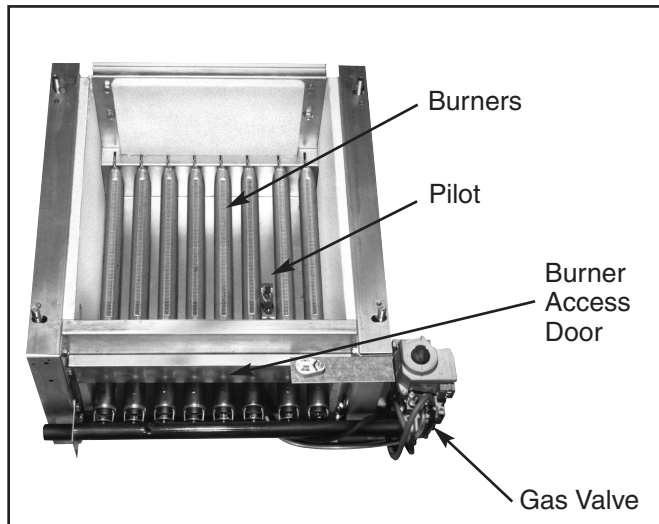

RIGHT END VIEW

VICTORY II SERIES BOILER

Location and identification of parts.

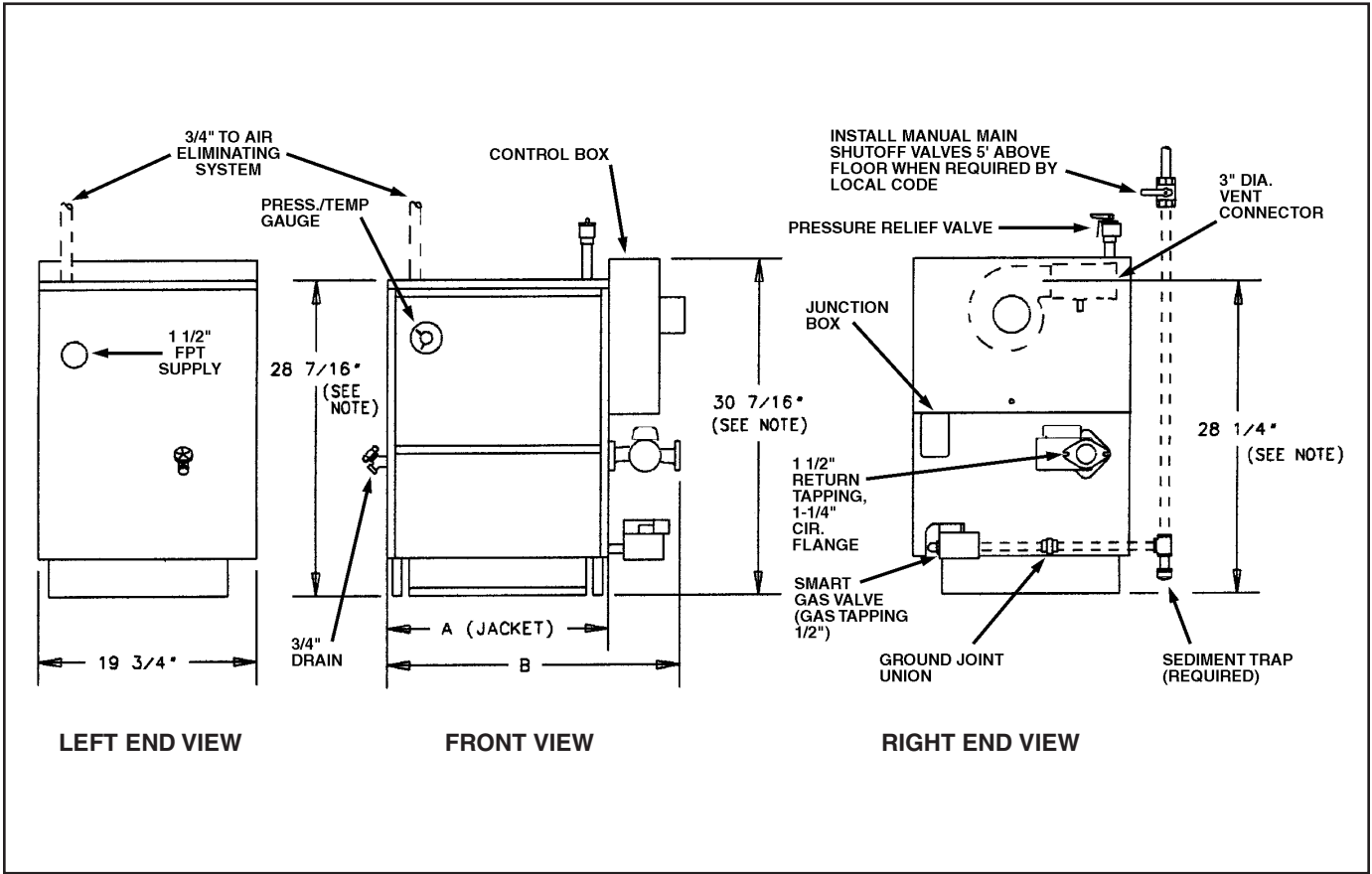

VICTORY II - VH, VHL BASE ASSEMBLY

Location and identification of parts.

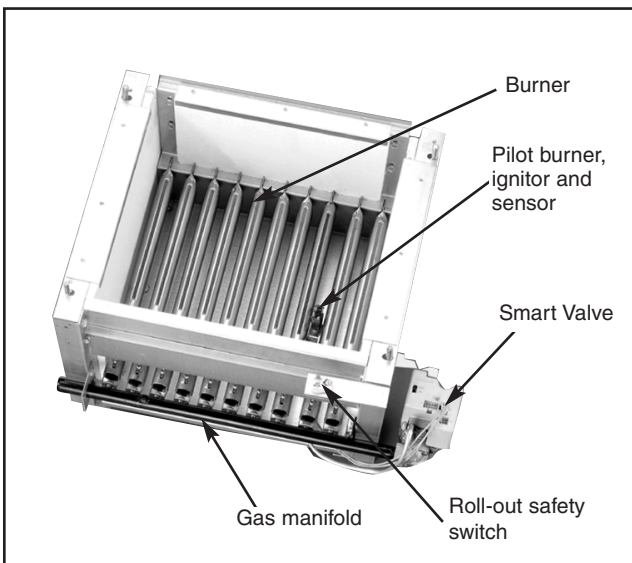

VICTORY II - VHS, VHLS BASE ASSEMBLY

Location and identification of parts.

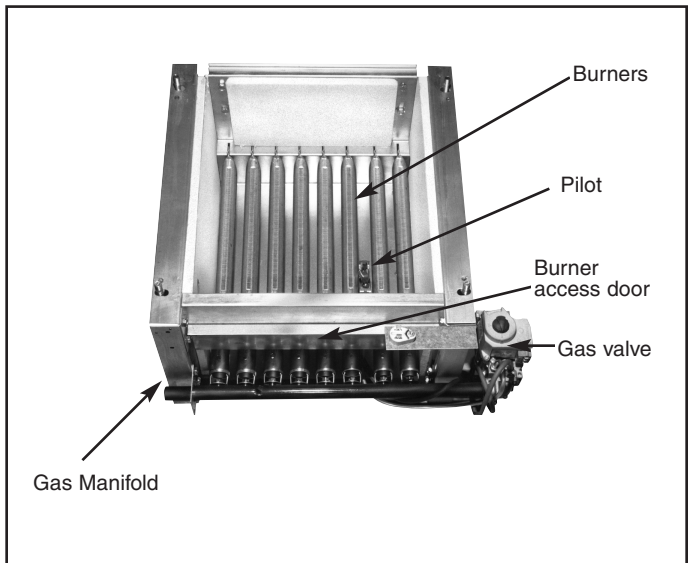

VICTORY V SERIES BOILER

Location and identification of parts.

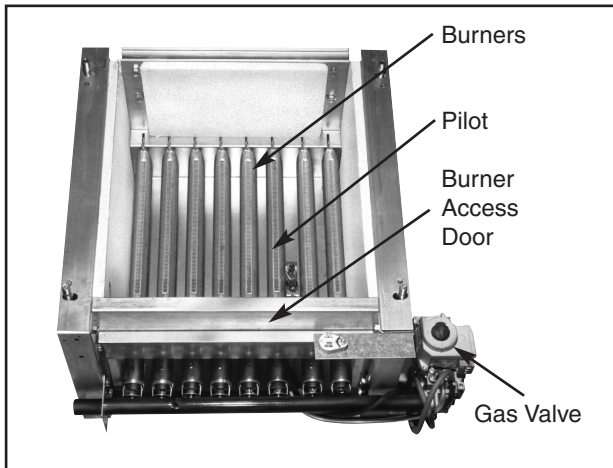
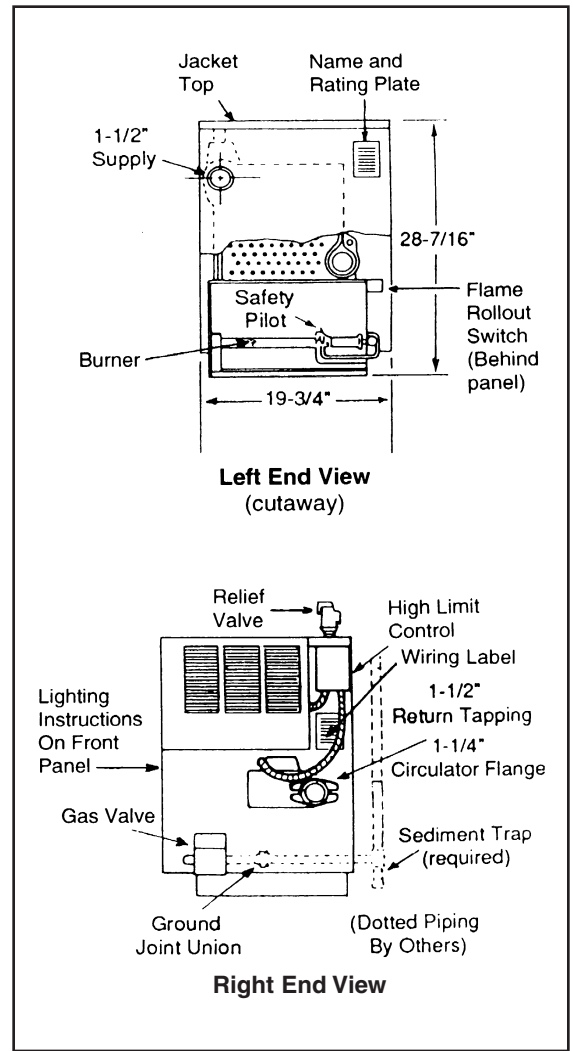
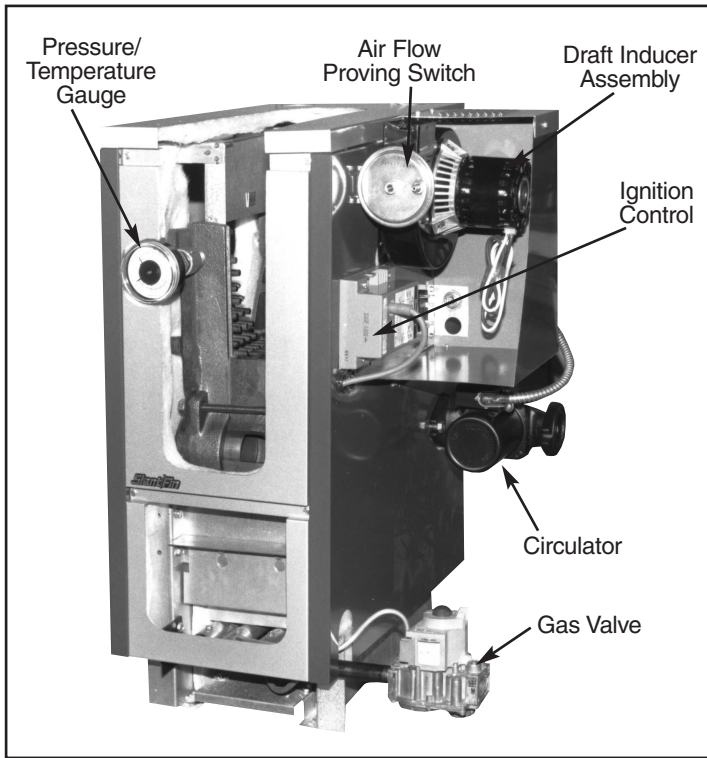

Base Assembly

GALAXY BOILER

Remove front panel (Figure 1) by pressing hand against panel and pushing up. Remove burner access door (Figure 2) by removing 2 wing nuts, slide panel forward and out.



Figure 1. Front Panel

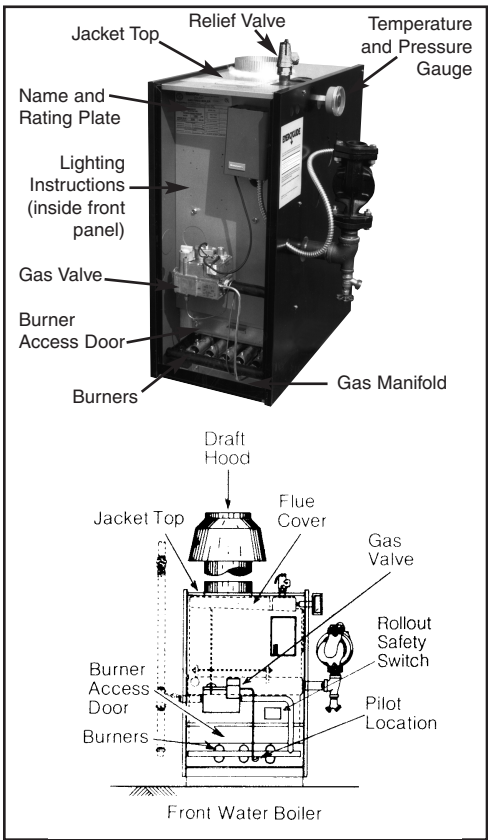

Figure 2.

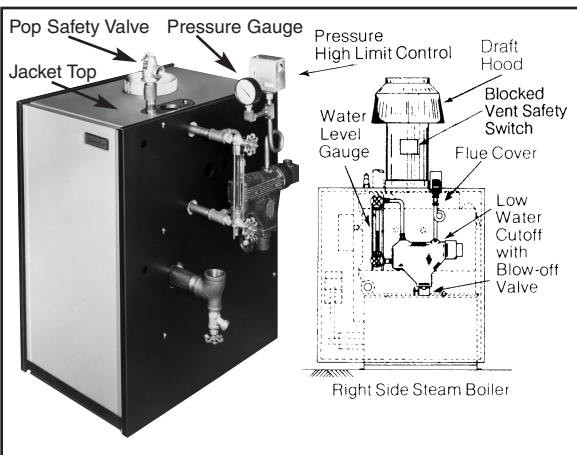

Figure 3.

BEFORE STARTING

Check contents for kit:

All components are either marked with a red stripe, a label with a model number or a stamped number on them.

1. Honeywell Conversion Kit:
 - a) Spring: propane = red; natural = stainless steel
 - b) Regulator adjusting screw
 - c) Cap screw: propane = black; natural = silver
 - d) Instructions
 - e) Label
2. Main Burner Orifices:

See Table 1 for the correct size orifice as it applies to this conversion.
3. Pilot Burner Assembly:
 - a) Pilot burner:

Standing pilot—Honeywell Q314A
Intermittent ignition—Honeywell Q345A
 - b) Pilot orifice:

Propane—Honeywell BBR-10
Natural—Honeywell BCR-18
4. Ignition Control (for IID only):

Honeywell S8600M (for Sentry, Sentinel or Victory V series boilers) or S8670E (for Galaxy boilers).
Required for conversion to propane only.
5. Three Labels: Boiler Conversion Label, Affidavit Label and Gas Valve Label.
6. Registration Card

Caution: The gas supply shall be shut off prior to disconnecting the electrical power, before proceeding with the conversion.

INSTALLATION

1. Turn Off Gas to Appliance
 - a) Set thermostat to lowest level.
 - b) Turn off all electric power to the appliance.
 - c) Turn the gas control knob clockwise to the off position.
 - d) Close all gas cocks.
 - e) CAUTION: LET BOILER COOL.
 - f) Remove front jacket panel.
 - g) Remove burner access door.
2. Gas Valve Conversion
 - a) Remove pressure regulator cap screw.
 - b) Remove pressure regulator adjusting screw.
 - c) Remove regulator spring.
 - d) Insert appropriate replacement spring (tapered end down).

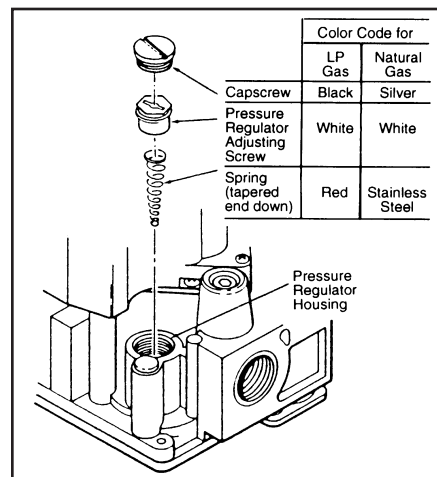

Figure 4. Conversion Kit Installation in Regulator

- e) Install new pressure regulator adjustment screw until it is flush with the top of the casting.
 - f) After e) above, turn adjustment screw clockwise as follows:
Propane Gas — 5-¾ full turns
Natural Gas — 6 full turns
 - g) Install the NEW cap screw.
 - h) Place the gas valve conversion label from the Honeywell kit over the gas valve model number.
3. Pilot Burner Conversion
- a) Disconnect pilot line from gas valve.
 - b) Disconnect flame sensor.
Standing pilot— disconnect thermocouple from gas valve.
Intermittent ignition — disconnect ignition wire from S8600 ignition control.
 - c) **BE SURE BURNERS ARE COOL BEFORE CONTINUING. NOTE LOCATION OF BURNER WITH PILOT. REMOVE THE BURNER RETAINER CLIP OF THE PILOT-BURNER. REMOVE THE BURNER. DISCONNECT THE PILOT TUBE AND EITHER THE THERMOCOUPLE FOR STANDING PILOT OR IGNITION WIRE FROM IGNITION CONTROL. (See figure 6).**
 - d) Remove pilot burner and replace with new pilot burner.
 - e) Replace pilot tubing on pilot burner. (It is best to cut off old ferrule and use new one to ensure a proper seal.)
 - f) Replace thermocouple or ignition wire on pilot assembly.
 - g) Remove existing main burner orifice from the manifold and replace with an orifice from the kit. (See figure 7).
 - h) Replace the pilot-burner into the boiler. Replace the burner retainer clip.
4. Orifice Replacement - Remove all other burner retainer clips and remove the rest of the burners.
- a) Remove existing main burner orifices from the manifold.
 - b) Install the orifices from the kit. (There may be more orifices than required.)
 - c) Reinstall the main burners making sure that the pilot burner is in the same position as above.
5. Ignition Control Replacement (for IID only)

IMPORTANT

FOR CONVERSION OF BOILERS EQUIPPED

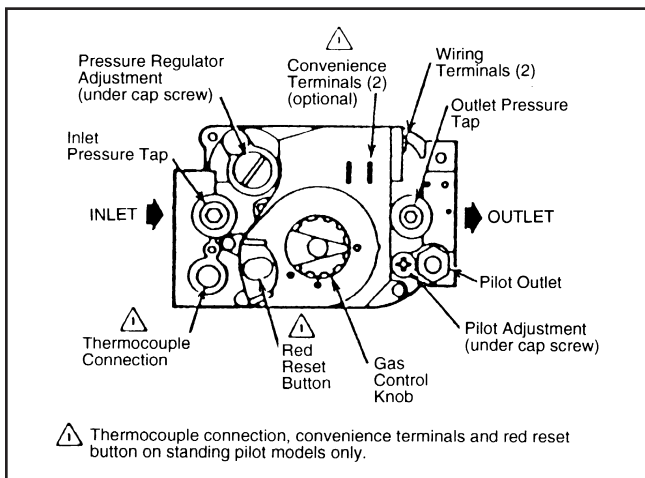

Figure 5. Gas Valve — top view

WITH AN INTERMITTENT IGNITION SYSTEM TO PROPANE, THE IGNITION CONTROL MUST BE CHANGED. FAILURE TO INSTALL THE CORRECT IGNITION CONTROL COULD CAUSE A HAZARDOUS CONDITION RESULTING IN AN EXPLOSION OR CARBON MONOXIDE POISONING AND WOULD VOID ANY WARRANTY.

- a) Remove the S8600F Control from the right side of the boiler. Note the location of the wires so that they may be installed on the proper terminals of the replacement control.
 - b) Install the NEW S8600M or S8670E control supplied in the kit. Reconnect the wires, including the ignition wire. Check applicable wiring diagram on pages 9 to 15 or the diagram on the boiler to make certain that the wiring is correct.
6. Registration Card and Labels:
- a) Fill out the Boiler Conversion Label, Affidavit Label and Gas Valve Label. Affix the Boiler Conversion Label adjacent to the rating plate on the boiler jacket. Affix the Affidavit Label to the front jacket panel adjacent to the Slant/Fin logo. Affix the Gas Valve label on the inside jacket panel above the gas valve.
 - b) Fill out the Registration Card. REMEMBER THAT THIS CARD MUST BE RECEIVED WITHIN 10 DAYS OR THE WARRANTY COULD BE VOIDED.

FINAL CHECKS:

1. Are the burners installed correctly (ports are up)?
2. Is the pilot in the correct position?
3. All of the wiring is correct?
4. All the labels have been filled out and affixed to the boiler?
5. Has the Registration Card been filled out?

GAS LEAK TESTS

Warning: DO NOT OMIT these tests. Open all gas cocks upstream of the boiler gas valve. Paint all pipe joints from the main gas cock to the gas valve with a rich soap and water solution. Bubbles indicate gas leakage. To stop the leak, tighten the joints and fittings. DO NOT USE AN OPEN FLAME FOR TESTING.

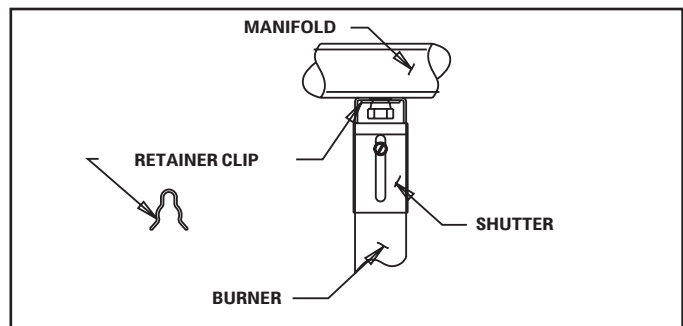

Figure 6. Burner/Manifold

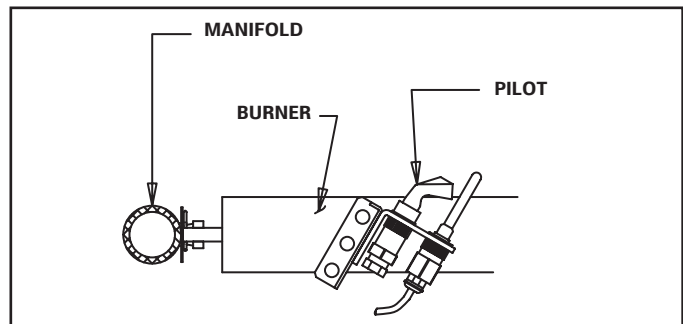

Figure 7. Pilot/Burner

**TABLE 1
ORIFICE SIZE TABLE**

SENTRY AND SENTINEL SERIES

Boiler Model	Gas Type	Orifice Size for Sea Level*	Orifice Sizes for High Altitudes Includes 4% Reduction for Each 1000 Feet								
			Elevation - Feet								
			2000	3000	4000	5000	6000	7000	8000	9000	10000
All Sentinel models and Sentry S-34	Natural	47	48	48	49	49	49	50	50	51	51
		56	56	56	57	57	57	58	59	59	60
Sentry S-60 thru S-150 & SX-150 thru SX-210	Natural	50	51	51	51	51	52	52	52	53	53
		57	58	59	59	60	60	61	62	63	63

VICTORY SERIES

Boiler Model	Gas Type	Orifice Size for Sea Level*	Orifice Sizes for High Altitudes Includes 4% Reduction for Each 1000 Feet								
			Elevation - Feet								
			2000	3000	4000	5000	6000	7000	8000	9000	10000
V-33	Natural	48	49	50	50	51	51	52	52	52	52
		56	56	56	57	57	58	59	59	6	6
V-60 thru V-180	Natural	50	51	51	51	52	52	52	52	53	53
		57	58	59	59	60	60	61	62	63	63
VSP, VSPH, VH & VHS	Natural	49	50	50	50	51	51	51	52	52	52
		57	58	59	59	60	60	61	62	63	63

GALAXY SERIES

Boiler Model	Gas Type	Orifice Size for Sea Level*	Orifice Sizes for High Altitudes Includes 4% Reduction for Each 1000 Feet								
			Elevation - Feet								
			2000	3000	4000	5000	6000	7000	8000	9000	10000
GG/GX Except GG-399H & GG-350H	Natural	42	43	43	43	43	44	44	45	46	47
		54	54	55	55	55	55	55	56	56	56
GG-399H	Natural	40	41	42	42	42	43	43	44	44	45
		53	54	54	54	54	54	54	55	55	55
GXH-105 through 275	Natural	44	45	45	45	46	47	47	48	48	49
		54	54	55	55	55	55	55	56	56	56
GXH-300	Natural	43	44	44	44	45	45	46	47	47	48
		54	54	55	55	55	55	55	56	56	56
GXH-300H	Natural **	42	43	43	43	43	44	45	45	46	47
		Gas Only	55	55	55	55	56	56	56	56	56
GXHA	Natural	45	46	47	47	47	48	48	49	49	50
		Gas Only	55	55	55	55	56	56	56	56	56

SENTINEL SERIES

Boiler Model	Gas Type	Orifice Size for Sea Level*	Orifice Sizes for High Altitudes Includes 4% Reduction for Each 1000 Feet								
			Elevation - Feet								
			2000	3000	4000	5000	6000	7000	8000	9000	10000
Sentinel	Natural	47	48	48	49	49	49	50	50	51	51
		56	56	56	57	57	57	58	59	59	60

VICTORY II - VHL, VHLS Series (Under 2000 Ft. Only)

Boiler Model	Gas Type	Orifice Size for Sea Level*
VHL, VHLS	Natural	49
	Propane	57

* Orifice indicated for sea level above are factory installed in boiler unless otherwise specified by the local authority.
See page 19 for burner input adjustment.

** For L.P. Propane consult factory.

**TABLE 2
INPUT RATING OF BOILERS**

		S-34	S-60	S-90	S-120	S-150	SX-150	SX-180	SX-210						
C.S.A. Input Rating (MBH)		34	60	90	120	150	150	180	210						
		GG-75	GG-100	GG-125	GG-150	GG-175	GG-200	GG-225	GG-250	GG-275	GG-300	GG-325	GG-350	GG-375	GG-399
C.S.A. Input Rating (MBH)		75	100	125	150	175	200	225	250	275	300	325	350	375	399
		GXH-105	GXH-125	GXH-150	GXH-170	GXH-190	GXH-210	GX-225	GXH-230	GX-250	GXH-250	GXH-275	GXH-300	GXHA-100	GXHA-160
C.S.A. Input Rating (MBH)		105	125	150	170	190	210	225	230	250	252	275	300	100	200
		VH-30	VH-60	VH-90	VH-120	VH-150	VH-180	VHS-30	VHS-60	VHS-90	VHS-120	VHS-150	VHS-180		
C.S.A. Input Rating (MBH)		30	60	90	120	150	180	30	60	90	120	150	180		
			VSP-60	VSP-90	VSP-120	VSP-150	VSP-180		VSPH-60	VSPH-90	VSPH-120	VSPH-150	VSPH-180		
C.S.A. Input Rating (MBH)			60	90	120	150	180		60	90	120	150	180		

Note: All models of the boilers will have the same input rating after converted.

LIGHTING INSTRUCTIONS

**Continuous Burning Pilot (24V).
FOR BOILERS EQUIPPED WITH GAS VALVES
VR8200 and VR8300.**

SAFETY INFORMATION

FOR YOUR SAFETY READ BEFORE LIGHTING

WARNING: If you do not follow these instructions exactly, a fire or explosion may result causing property damage, personal injury or loss of life.

- This appliance has a pilot which must be lighted by hand. When lighting the pilot, follow these instructions exactly.
- BEFORE LIGHTING** smell all around the appliance area for gas. Be sure to smell next to the floor because some gas is heavier than air and will settle on the floor.
WHAT TO DO IF YOU SMELL GAS
 - DO NOT try to light any appliance.
 - DO NOT touch any electric switch; DO NOT use any phone in your building.
 - Immediately call your gas supplier from a neighbor's phone. Follow the gas supplier's instructions.
 - If you cannot reach your gas supplier, call the fire department.
- Use only your hand to push in or turn the gas control knob. NEVER use tools. If the knob will not push in or turn by hand, DON'T try to repair it, call a qualified service technician. Force or attempted repair may result in a fire or explosion.
- DO NOT use this appliance if any part has been underwater. Immediately call a qualified service technician to inspect the appliance and to replace any part of the control system and any gas control which has been underwater.

Lighting Instructions

- STOP!** Read the safety information above on this page.
- Set the thermostat to lowest setting.
- Turn off all electric power to the appliance.
- Remove control access panel. (Galaxy models only.)
- Push in gas control knob slightly and turn clockwise ↻ to "OFF".

VALVE VR8200
OR VR8300

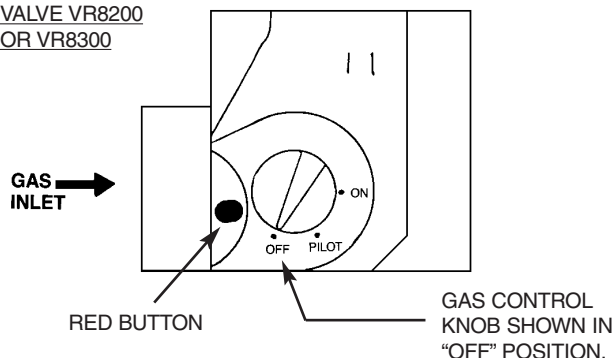

- Wait five (5) minutes (longer for propane) to clear out any gas. If you then smell gas, **STOP!** Follow "B" in the safety information. If you don't smell gas, go to next step.
- Remove the pilot access panel located below and behind the gas control unit.
- Find pilot—follow the aluminum tubing from the gas valve. The pilot is between two burner tubes behind the burner access panel.
- Turn knob on gas control counterclockwise ↶ to "PILOT".
- Push in red button all the way and hold in. Immediately light the pilot with a match. Continue to hold the red button in for about one (1) minute after the pilot is lit. Release knob and it will pop back up. Pilot should remain lit. If it goes out, repeat steps 5 through 10.
 - If knob does not pop up when released, stop and immediately call your service technician or gas supplier.
 - If the pilot will not stay lit after several tries, turn the gas control knob to "OFF" and call your service technician or gas supplier.
- Replace pilot access panel.
- Turn gas control knob counterclockwise ↶ to "ON".
- Replace control access panel. (Galaxy models only.)
- Turn on all electric power to the appliance.
- Set thermostat to desired settings.



To Turn Off Gas To Appliance

- Set the thermostat to lowest setting.
- Turn off all electric power to the appliance if service is to be performed.
- Remove control access panel. (Galaxy models only.)
- Turn gas control knob clockwise ↷ to "OFF". DO NOT force.
- Replace control access panel. (Galaxy models only.)

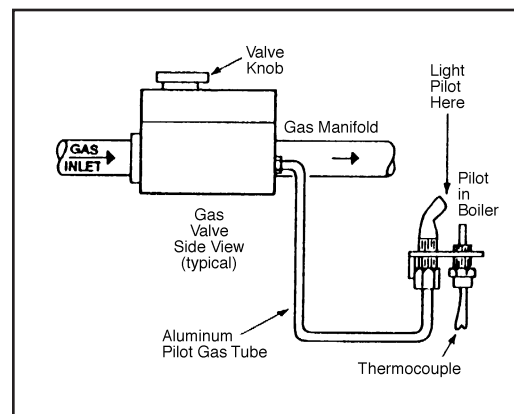

**HONEYWELL IID SYSTEM .
FOR BOILERS EQUIPPED WITH GAS VALVE VR8204 OR
VR8304.**

SAFETY INFORMATION

FOR YOUR SAFETY READ BEFORE LIGHTING

WARNING: If you do not follow these instructions exactly, a fire or explosion may result causing property damage, personal injury or loss of life.

- A. This appliance is equipped with an ignition device which automatically lights the pilot. **DO NOT** try to light the pilot by hand.
- B. **BEFORE OPERATING** smell all around the appliance area for gas. Be sure to smell next to the floor because some gas is heavier than air and will settle on the floor.
 - WHAT TO DO IF YOU SMELL GAS**
 - **DO NOT** try to light any appliance.
 - **DO NOT** touch any electric switch; **DO NOT** use any phone in your building.
 - Immediately call your gas supplier from a neighbor's phone. Follow the gas supplier's instructions.
 - If you cannot reach your gas supplier, call the fire department.
- C. Use only your hand to push in or turn the gas control knob. **NEVER** use tools. If the knob will not push in or turn by hand, **DON'T** try to repair it, call a qualified service technician. Force or attempted repair may result in a fire or explosion.
- D. **DO NOT** use this appliance if any part has been underwater. Immediately call a qualified service technician to inspect the appliance and to replace any part of the control system and any gas control which has been underwater.

Lighting Instructions

- 1. **STOP!** Read the safety information above.
- 2. Set the thermostat to lowest setting.
- 3. Turn off all electric power to the appliance.
- 4. This appliance is equipped with an ignition device which automatically lights the pilot. **DO NOT** try to light the pilot by hand.

GAS VALVE VR8204
OR VR8304

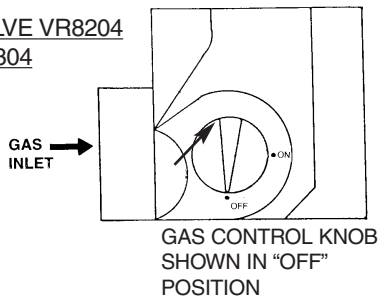

- 5. Remove control access panel. (Galaxy models only.)
- 6. Turn gas control knob clockwise till knob stops, continue to "OFF". **DO NOT** force.
- 7. Wait five (5) minutes (longer for propane) to clear out any gas. If you then smell gas, **STOP!** Follow "B" in the safety information. If you don't smell gas, go to next step.
- 8. Turn gas control knob counterclockwise to "ON".
- 9. Replace control access panel. (Galaxy models only.)
- 10. Turn on all electric power to the appliance.
- 11. Set thermostat to desired setting.
- 12. If the appliance will not operate, follow the instructions "To Turn Off Gas To Appliance" and call your service technician or gas supplier.

To Turn Off Gas To Appliance

- 1. Set the thermostat to lowest setting.
- 2. Turn off all electric power to the appliance if service is to be performed.
- 3. Remove control access panel. (Galaxy models only.)
- 4. Turn gas control knob clockwise till knob stops, then continue to "OFF". **DO NOT** force.
- 5. Replace control access panel. (Galaxy models only.)

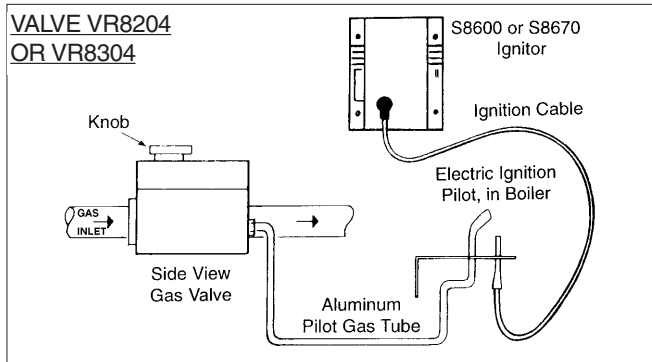

BURNER ADJUSTMENT

- A. Adjust gas input rate:
 - 1. Consult gas supplier for higher heating value of gas (Btu/cu.ft.)
 - 2. Set thermostat high enough so that boiler will remain on while checking rate.
 - 3. Measure manifold pressure at 1/8" tapping. See label provided with the conversion kit for the correct manifold pressure for the gas that is being supplied. **NOTE:** Gas pressure may be adjusted by turning pressure regulator screw on combination gas valve (turn clockwise to increase pressure, counterclockwise to decrease pressure). See page 17 for the input rate of your boiler.
 - a. Input for **PROPANE** is approximately at rating shown on rating plate when manifold pressure is 9 1/2" water column.
 - b. Input for **NATURAL GAS** is approximately at rating when manifold pressure is 3 1/2" water column, but should be checked on the gas meter:

$$\text{Btuh Input} = \text{Btu/cu. ft.} \times \text{cu. ft. metered in 3 minutes} \times 20$$

Example 1:
For 1000 Btu/cu.ft. gas, this becomes:
Btuh Input = cu. ft. metered in 3 minutes
x 1,000 Btu/cu.ft. x 20

Example 2:
For 1050 Btu/cu.ft. gas, this becomes:
Btuh Input = cu. ft. metered in 3 minutes
x 1050 Btu/cu.ft. x 20

- 4. The higher* heating value of gas varies substantially for different localities. Consult with Slant/Fin's Technical Service Dept. for re-orificing procedures if any of the following apply:
 - a. Boiler (burner) is overfiring. **CAUTION!** National Fuel Gas Code ANSI Z223.1-latest edition does NOT permit firing at a higher input rate than the input rate indicated on the boiler rating plate in order to avoid hazardous conditions such as explosion or carbon monoxide poisoning.
 - b. Poor higher* heating value of gas is causing the actual input to be substantially lower than the rating plate indication.

* "Higher heating" value of gas is commonly known as "heating value".

GAS RATE TABLE	
Boiler rated input cu. ft./hr. of 1000 Btu/cu. ft. Natural Gas	Cubic Feet Gas Consumption 1000 Btu/cu.ft. gas, in 3 minutes, at rated input
33	1.65
34	1.70
60	3.00
70	3.50
75	3.75
90	4.50
100	5.00
105	5.25
120	6.00
125	6.25
140	7.00
150	7.50
175	8.75
180	9.00
200	10.00
210	10.50
225	11.25
245	12.25
250	12.50
275	13.75
300	15.00
325	16.25
350	17.50
375	18.75
399	19.95

The gas metered in 3 minutes to obtain rated input for each boiler model using 1000 Btu/cu.ft. gas is tabulated in the gas rate table.

B. Main Burner

1. Fire the boiler continuously for at least 15 minutes, to reach burner operating temperature.
2. Observe the flames, all burners. The base of all flame jets should be blue. The tips should be blue shading to orange.

NOTE: Dust, disturbed by any movement, will cause bright orange flames. Wait for dust to settle.

3. For one burner, close the air shutter until some of its flame jet tips turn yellow-white, indicating insufficient primary air. Then open shutter until whitish tips disappear completely. Set all burner shutters to the same opening. Observe to make sure that no yellow-white tips appear over any portion of the flame. Small yellow tips at the pilot location are permitted.

NOTE: This adjustment method gives MINIMUM primary air setting for safe combustion. DO NOT attempt to make this adjustment unless burners are at operating temperature. Adjustment should be made with burner access panel in final operating position. Use of a mirror may be helpful to observe flames. Note that burner ports are on top of main burner tube.

C. Main Burner Ignition Checkout and Pilot Adjustment

1. The pilot flame must not smother or snuff out when tested as follows:
 - a. Main burner ignition from cold start-repeat.
 - b. Continued operation of main burner.
 - c. Main burner ignition with appliance at maximum operating temperature after prolonged operation.

NOTE: Observe operation of the pilot burner with appliance doors in the final operating position. Use of a mirror may be helpful.

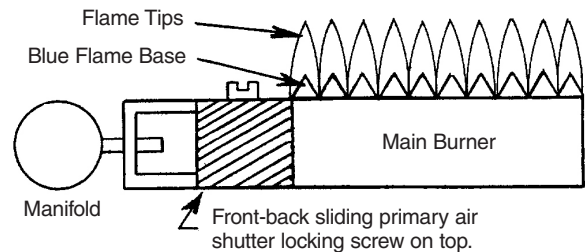

2. Safety Shutdown Checkout

- a. For proper operation the pilot should engulf the thermocouple or flame sensor as shown below.
- b. To adjust pilot, turn pilot flow adjustment screw on valve clockwise or counterclockwise to give a steady flame enveloping 3/8" to 1/2" inch of the tip of the thermocouple or flame sensor. Note that turning the pilot adjustment screw clockwise will decrease the pilot flame.

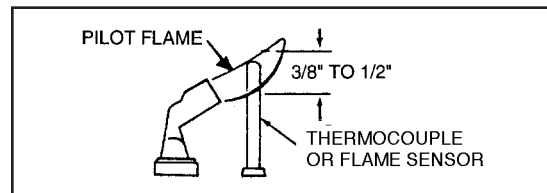

Gas Pressure (inches of wc)

Gas	Manifold	Minimum Inlet	Maximum Inlet
Natural Gas	3.5"	5"	11"
LP Propane	9.5"	11"	14"

