

Slant/Fin®

★ LIBERTY® II

OIL-FIRED WATER AND STEAM BOILERS/NO. 2 OIL

SERVICE COMPANY

Name _____
 Address _____
 Telephone _____
 Model # _____
 Serial # _____

INSTALLATION AND OPERATING INSTRUCTIONS

READ AND SAVE THESE INSTRUCTIONS FOR REFERENCE.

SAFETY WARNING:

KEEP BOILER AREA CLEAR AND FREE FROM COMBUSTIBLE MATERIALS, GASOLINE AND OTHER FLAMMABLE VAPORS AND LIQUIDS. FAILURE TO ADHERE TO ABOVE SAFETY WARNING, MAY RESULT IN PERSONAL INJURY OR DEATH AND PROPERTY DAMAGE.

CONTENTS	PAGE
Ratings and Dimensions	2
Installation Requirements:	
Boiler Location	3
Clearances	3
Chimney Requirements	3
Air Supply and Venting	3
Controls and Accessories	7
Piping for Steam Boilers	7
Cleaning Piping System	7
Piping for Water Units	7
Piping for Tankless Heater	8
Installing Burner	8
Oil Supply Piping	8
Wiring the Boiler	8
Vent Piping and Draft Regulator	9
Operating Instructions:	
Precautions Before Starting	9
Start-up	9
Cleaning and Filling New Water Boiler	9
Blowing Off a Steam Boiler	7, 10
Cleaning and Filling New Steam Boiler	10
Low Water Cut-off Check-out	10
Pressure Control Check-out	11
Replacement of Steam Boiler	11
Wiring Diagrams	12-15
Burner Data	16-21
Care and Maintenance:	
Extended Shutdown	22
Freezing Protection	22
Oil Burner	22
General Maintenance	22



IMPORTANT: The installation of this equipment must conform to the requirements of the authority having jurisdiction or, in the absence of such requirements, to the Installation of Oil Burning Equipment, ANSI/NFPA 31, latest edition, and to the National Electrical Code ANSI/NFPA 70, latest edition. The installation must also conform to the additional requirements in this Slant/Fin Instruction Manual. Where there is any difference, the more stringent requirement shall govern.

In addition, where required by the authority having jurisdiction, the installation must conform to American Society of Mechanical Engineers Safety Code for Controls and Safety Devices for Automatically Fired Boilers, No. CSD-1, latest edition.

THIS MANUAL MUST BE LEFT WITH OWNER AND SHOULD BE HUNG ON OR ADJACENT TO THE BOILER FOR REFERENCE.

IMPORTANT: This boiler must be installed by a trained, experienced, service technician, licensed for the installation and servicing of oil burning equipment or otherwise qualified by the authorities having jurisdiction over the installation.

TAPPINGS AND OPENINGS

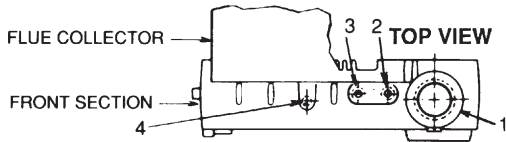

Tapping Location	Steam Boiler	Water Boiler
1	3" supply	1 1/2" supply
1A	2" supply on rear section *	—
2	second 1/4" siphon & pressure cutout if required	3/4" air vent or expansion tank
3	3/4" steam safety valve	3/4" water relief valve
4	1/4" siphon, pressure gauge & pressure cut-out	—
5A	—	1/2" tankless inlet
5B	—	1/2" tankless outlet
6	—	1/4" pressure temp. gauge
7	—	1/2" high limit, hi/lo or combination control
8	3/4" alternate electronic low water cut-off	—
9	1 1/2" skimmer tapping	—
10	1/2" low limit for tankless	—
11A	1/2" tankless inlet	—
11B	1/2" tankless outlet	—
12	1/2" steam gauge glass & 67 LWCO	—
13	1 1/2" bushed to 3/4" for drain cock	1 1/2" return & 3/4" drain cock
14	1 1/2" condensate return	1 1/2" alternate return
15	3/4" NPT zone tapping	—

FRONT VIEW WATER

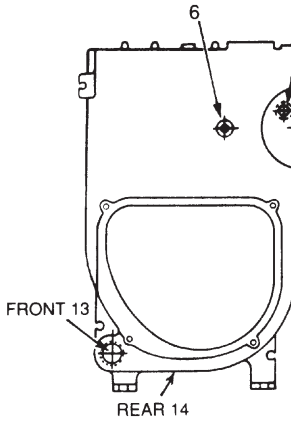

FRONT VIEW STEAM

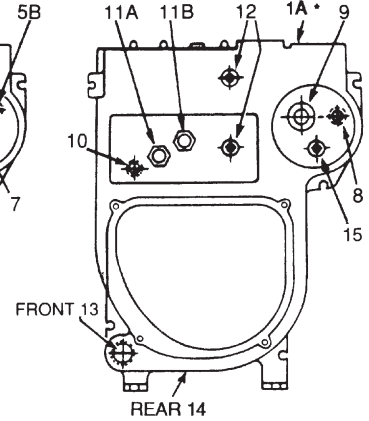

Figure 1

* Rear section LD-50, LD-60, LD-70 steam boilers only.

DIMENSIONS

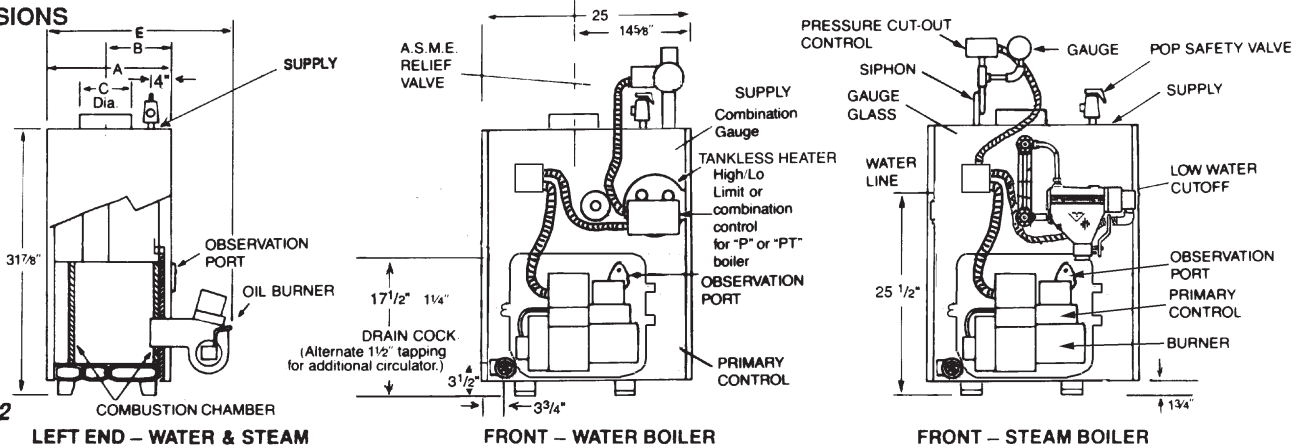

Figure 2

RATINGS

Boiler Model No.*	AHRI Burner Capacity Oil Input		D.O.E. Heating Capacity MBH		AHRI Net Ratings			AHRI Chimney Size		A.F.U.E. %		Dimensions (inches)					Tankless Heater GPM**		
	GPH †	BTUH	Water	Steam	Water MBH †	Steam MBH †	Steam Sq. Ft.	Nom. Rect. x Height § (in x in x ft)	I.D. Round x Height (in x ft)	Water	Steam	Boiler Length "A"	Front to Flue "B"	Flue Dia. "C"	Return Circulator Flange "D"	Overall Length "E"	Boiler Sect.	Water	Steam
LD-20	0.75	105,000	90	—	79	—	—	8 x 8 x 15	5 x 15	83.50	—	11 1/2	8 9/32	6	1 1/4	24 1/4	2	2.20	—
LD-30H	1.00	140,000	121	—	105	—	—	8 x 8 x 15	6 x 15	86.00	—	14 7/8	10 1/32	6	1 1/4	27 5/8	3	3.10	—
LD-30H	1.10	154,000	134	134	117	101	421	8 x 8 x 15	6 x 15	84.85	84.15	14 7/8	10 1/32	6	1 1/4	27 5/8	3	3.20	3.00
	1.25	175,000	151	—	131	—	—	8 x 8 x 15	6 x 15	83.50	—	14 7/8	10 1/32	6	1 1/4	27 5/8	3	3.40	—
LD-40H	1.50	210,000	182	179	158	134	558	8 x 8 x 15	7 x 15	86.00	84.00	18 1/4	11 29/32	7	1 1/4	31	4	3.80	3.40
LD-40H	1.60	224,000	195	195	170	146	608	8 x 8 x 15	7 x 15	84.45	83.80	18 1/4	11 29/32	7	1 1/4	31	4	3.90	3.50
	1.80	252,000	218	—	190	—	—	8 x 8 x 15	7 x 15	83.33	—	18 1/4	11 29/32	7	1 1/4	31	4	4.15	—
LD-50H	2.00	280,000	243	239	211	179	746	8 x 8 x 15	8 x 15	86.00	84.00	21 5/8	13 19/32	8	1 1/2	34 3/8	5	4.30	3.90
LD-50H	2.10	294,000	256	255	223	191	796	8 x 8 x 15	8 x 15	84.06	83.45	21 5/8	13 19/32	8	1 1/2	34 3/8	5	4.40	4.00
	2.35	329,000	272 ‡	—	237	—	—	8 x 12 x 15	8 x 15	—	—	21 5/8	13 19/32	8	1 1/2	34 3/8	5	4.70	—
LD-60H	2.60	364,000	298 ‡	298 ‡	259	224	933	8 x 12 x 15	10 x 15	—	—	25	15 3/32	8	1 1/2	37 3/4	6	4.90	4.50
	2.85	399,000	327 ‡	—	284	—	—	8 x 12 x 15	10 x 15	—	—	25	15 3/32	8	1 1/2	37 3/4	6	5.20	—
LD-70H	3.10	434,000	354 ‡	354 ‡	306	266	1108	8 x 12 x 15	10 x 15	—	—	28 3/8	16 25/32	9	—	41 1/8	7	5.45	5.00
	3.35	469,000	381 ‡	—	331	—	—	8 x 12 x 15	10 x 15	—	—	28 3/8	16 25/32	9	—	41 1/8	7	5.70	—

Standard working pressure 30 psi water, 15 psi steam.
All boilers hydrostatically tested — A.S.M.E.

* For forced hot water heating systems where the boiler and all piping are located within the area to be heated, the boiler may be selected on the basis of gross D.O.E. capacity output. The net AHRI output ratings shown are based on an allowance for piping and pickup of 1.15 (water) or 1.33 (steam). D.O.E. capacity gross output is divided by the allowance to obtain net rating. The manufacturer should be consulted before selecting a boiler for unusual piping and pickup requirements such as intermittent system operation, extensive piping, etc.

† Ratings apply to the use of light oil at 140,000 Btu per gallon, and apply only when burner models listed on pages 14-16 of this manual are used, and are properly adjusted to produce 13% CO₂.

§ Nominal clay tile liner dimensions.

** Tankless heater rating based on intermittent draw.

¶ Water boiler models LD-30 and larger have two firing rates. The boiler is factory shipped at the lower firing rate. To obtain the higher firing rate, refer to the Liberty II boiler installation instructions for the appropriate field adjustments.

‡ I.B.R. gross output

□ Collar is oblong, will fit 6" diameter nominal connector.

© This dimension is from the boiler jacket to the center of the flue outlet.

NOTE: All boilers under 300,000 Btu/h input are tested and rated for capacity under the U.S. Department of Energy (D.O.E.) test procedures for boilers.

INSTALLATION REQUIREMENTS

BOILER LOCATION

Provide a level, solid foundation for the boiler. Location should be near the chimney so that the Flue Pipe Connector or Breeching to the chimney is short and direct.

- A. The foundation must be capable of supporting the weight of the boiler when filled with water:

Boiler Size	Approximate Total Weight of Boiler Assembly, filled with water
LD-20	440
LD-30	550
LD-40	660
LD-50	785
LD-60	895
LD-70	1000

- B. The boiler can be installed on both combustible and non-combustible floors, but must NOT be installed on or above carpeting.
- C. The Intrepid Boiler has full wet base sections which surround fire-box for maximum heat absorption of burning fuel, and low floor temperature.
- D. If boiler is to be located over buried conduit containing electric wires or telephone cables, consult local codes or the National Board of Fire Underwriters for specific requirements.

CAUTION: NEVER BURN GARBAGE OR PAPER IN THE UNIT AND NEVER LEAVE COMBUSTIBLE MATERIAL AROUND IT.

MINIMUM CLEARANCE

Provide accessibility clearance of 24" from surfaces requiring servicing (top and front) and 18" on any side requiring passage. The boiler shall be installed with the following MINIMUM clearances from combustible materials:

- A. CHIMNEY CONNECTOR-18"
- B. BACK AND SIDES- 6" EXCEPT as limited by 18" clearance from chimney connector

NOTE: Except in closets and alcoves, clearances above in (A) and (B) may be reduced by providing forms of protection as specified in NFPA 31, latest edition.

CHIMNEY REQUIREMENTS

- A. The chimney must be constructed in accordance with all local applicable codes and the National Board of Fire Underwriters. See boiler models and rating table shown on page 2 for chimney sizes.
- B. Check chimney condition. Existing chimneys and stacks may have deteriorated; without repairs their use would be hazardous. Before connecting to an old chimney or stack:
 - 1. Clean it.
 - 2. Inspect it thoroughly.
 - 3. Remove obstructions.
 - 4. Replace worn sections of metal stacks.
 - 5. Seal bad masonry joints.
 - 6. Repair damaged linings.
- C. Where more than one appliance vents into a common chimney, the area of the common breeching should at least equal the area of the largest appliance flue plus 50% of the additional flue areas.
- D. Breeching area must not be reduced at connection into chimney. Breeching must be inserted into, but not beyond, inside of chimney liner.
- E. Chimney height shall extend at least 3 feet above where it passes through the roof of the building, and at least 2 feet above any ridge within 10 feet of the chimney.
- F. The use of a vent cap, where permitted by code, gives additional protection against adverse wind conditions and precipitation.
- G. Flue Connection: Connect flue pipe between top of boiler and chimney. Horizontal sections of flue pipe must be pitched upward to the chimney at least 1/4" per foot. Flue must be inserted into, but not extend beyond, the inside wall of the chimney flue. Install draft regulator in flue pipe, as shown in figure 3.

AIR SUPPLY AND VENTILATION (see NFPA 31, latest edition)

Sufficient air for combustion and ventilation in the boiler room must be provided. Failure to do this will result in poor combustion, heavy sooting and health hazards.

CAUTION: AN OIL-FIRED UNIT SHALL BE CONNECTED TO A VENT HAVING A SUFFICIENT DRAFT AT ALL TIMES TO ENSURE SAFE AND PROPER OPERATION OF THE UNIT.

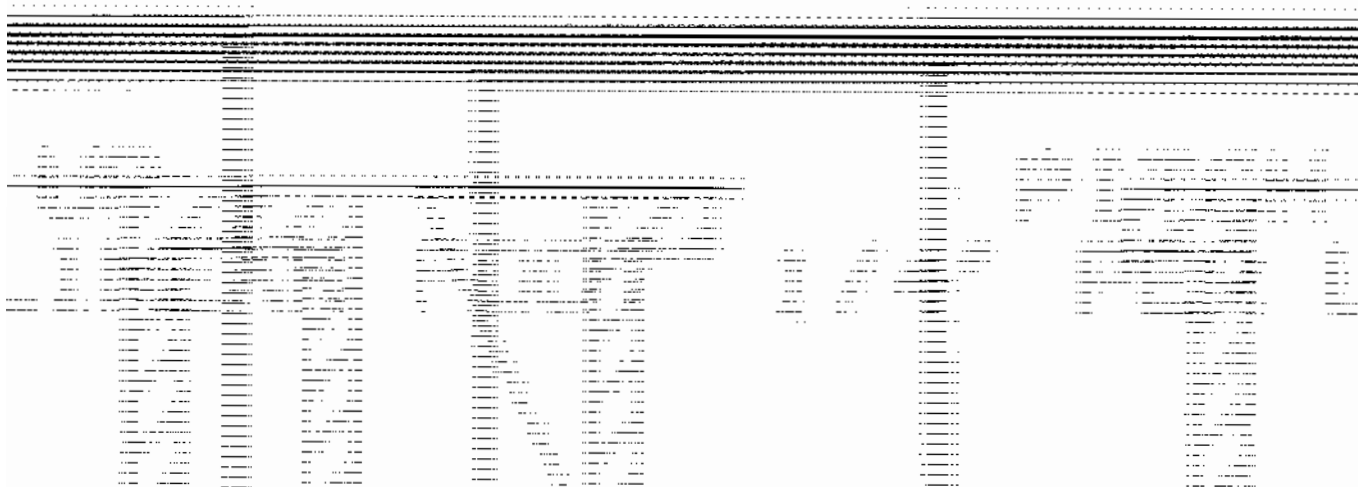

Sufficient space shall be left clear around the boiler.

Do not stack items on or box in the appliance within the required clearances to combustibles.

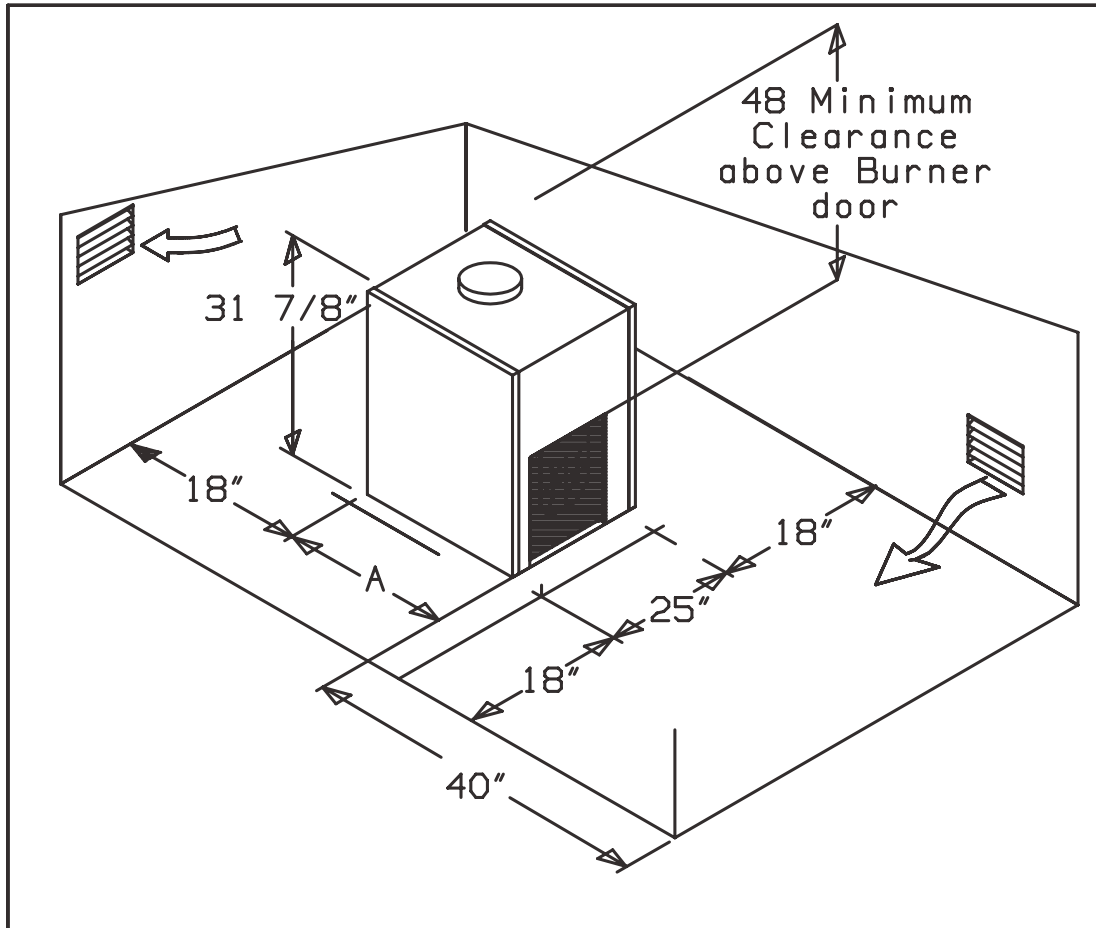

BOILER MODELS	A (in)
TR-20 / LD-20	11 1/2"
TR-30H / TR(DV)-30 / LD-30	14 7/8"
TR-40H / TR-40 / LD-40	18 1/4"
TR-50H / TR-50 / LD-50	21 5/8"
TR-60 / LD-60	25"
TR-70 / LD-70	28 3/8"

Any oil-fired boiler must have a steady draft* and an ample supply of combustion air at all times during firing. If air supply or chimney draft* is unreliable, CO₂ and overfire draft* will change unpredictably.

DO NOT vent this boiler to the same chimney flue used by a fireplace or coal or wood burning furnace or boiler. The draft* produced by solid fueled devices varies tremendously between high fire and low fire:

In modern, weather stripped, energy-saving buildings or older buildings which have been modified similarly, natural infiltration may not supply enough air for combustion, particularly if other fuel burning appliances, exhaust fans or draft inducers are competing for the same air supply. Fireplaces, other solid fuel burning appliances and exhaust fans consume great quantities of air; if air supply is not ample, such an appliance will create a downdraft in the oil-fired boiler flue. This can create a hazardous condition. Flue gases can be sucked out of the chimney through

the vent regulator into the living space. DO NOT operate this boiler and a solid fuel burning appliance at the same time, unless the solid fuel burner is provided with its own outside air supply.

See Table 2, "Provisions for Combustion and Ventilation Air Supply" for determining need and method of providing air for combustion and ventilation.

If fly screen must be used over air supply openings, areas calculated should be doubled; the screen should be inspected and cleaned frequently to maintain free air flow.

Protect air openings against closure by snow, debris, etc. Openings such as doors or windows, if used, must be locked open.

* Draft is negative or suction pressure

TABLE 2: Provisions for Combustion and Ventilation Air Supply. See NFPA 31, latest edition for more detailed information.

	Boiler Location	Air Supply	Action Required
2.1	Unconfined space	Is there sufficient air for combustion by natural infiltration (see NOTE (1), "Test..." below)?	NONE
2.2	Unconfined space	If there is NOT sufficient air for combustion by natural infiltration due to tight construction or other conditions, then it REQUIRES AIR FROM OUTDOORS. SEE "ACTION REQUIRED" column at right. See Notes (1) and (2) below.	Provide air from outdoors directly through a permanent outside wall opening or openings with a free open area of not less than 1 sq. in. per 4000 Btu/hr of TOTAL input of ALL fuel burning appliances in the building. See Note (1) and (3).
2.3	Confined space	If there is sufficient air for combustion from within building but it comes from outside of the confined space. SEE "ACTION REQUIRED" column at right. See Note (1) below.	The confined space shall be provided with two permanent air openings, one near the top of the enclosure and one near the bottom. EACH opening shall have a free air opening of not less than 1 sq. in. per 1000 Btu/hr. of TOTAL input of ALL fuel burning appliances within the enclosure. The two openings shall freely communicate with the interior areas of the building which in turn would have to have adequate infiltration of air from outdoors. See Notes (1, 3) and Figure 3a.
2.4	Confined space	If there is NOT sufficient air for combustion due to tight construction or other conditions it REQUIRES AIR FROM OUTDOORS. SEE "ACTION REQUIRED" column at right. See NOTE (2) below.	(a) Air from the outdoors shall be provided to the confined space by two permanent openings, one in or near the top of the enclosure space and one in or near the bottom. The openings shall communicate directly, or by means of ducts, with outdoors or to such spaces (crawl or attic) that freely communicate with outdoors (See figures 3b, 3c and 3d). (b) Where directly communicating with outdoors or by means of vertical ducts, each opening shall have a free area of not less than 1 sq. in. per 4,000 Btu/hr. (35 sq. in. per gal. per hr.) of TOTAL input rating of ALL appliances in the enclosure. If horizontal ducts are used, each opening shall have a free area of not less than 1 sq. in. per 2,000 Btu/hr. (70 sq. in. per gal. per hr.) of TOTAL input of ALL appliances in the confined space. See Figures 3b, 3c and 3d.

(1) Test for sufficient air for combustion by infiltration by running this boiler for 30 minutes under all of the following conditions and at the same time: a) all doors, windows and other like openings must be closed, b) all fuel burning appliances should be FIRING, c) all exhaust fans and clothes dryers turned ON. At the above conditions the CO₂, smoke and draft readings must be normal. (CO₂ between 11% and 13%, smoke between ZERO and a TRACE, draft between .02" W.C. and .04" W.C. negative pressure.)

(2) Aside from tight construction, some of the conditions that steal air for combustion from a boiler are other fuel burning appliances, exhaust fans and clothes dryers.

(3) Generally, louvers made of wood have a free open area of 20% and those made of metal have a 60% to 70% free open area. Screens also reduce the open area of the louvers.

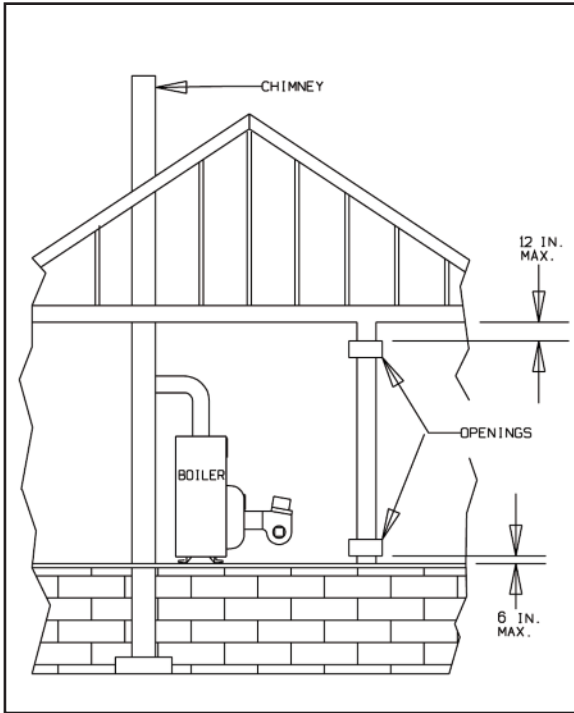

Figure 3a.
Appliances located in confined spaces. Air from inside the building. See Table 2 (2.3).

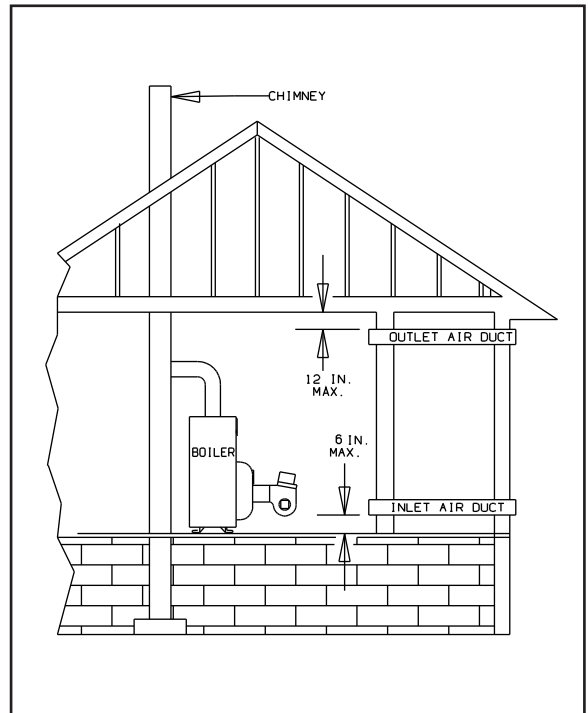

Figure 3b.
Appliances located in confined spaces. Air from outdoors. See Table 2 (2.4).

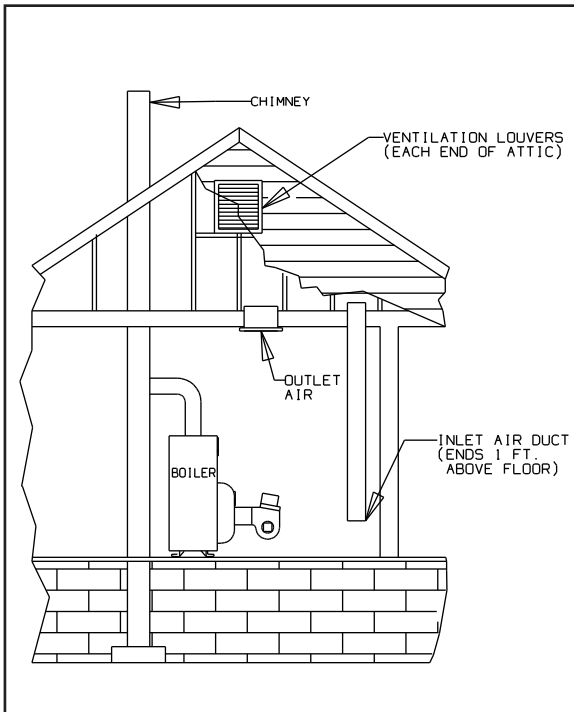

Figure 3c.
Appliances located in confined spaces. Air from outdoors through ventilated attic. See Table 2 (2.4).

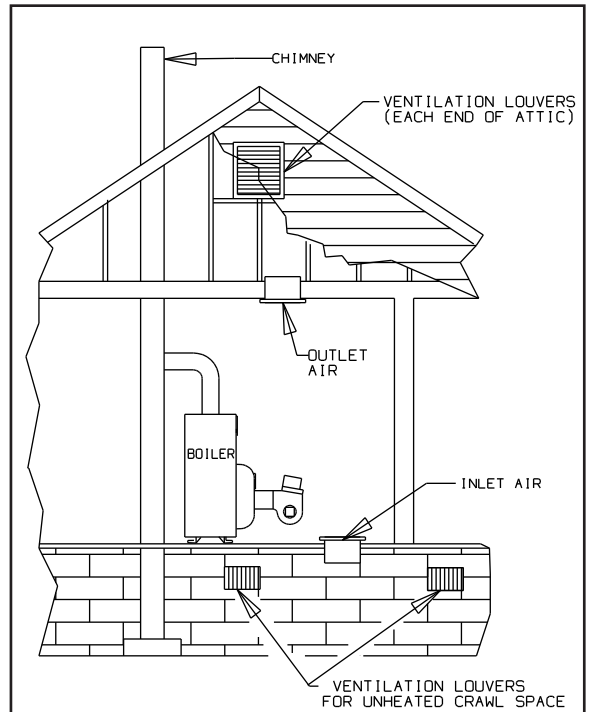

Figure 3d.
Appliances located in confined spaces. All air from outdoors through ventilated crawl space and outlet air to ventilated attic. See Table 2 (2.4).

INSTALLING CONTROLS AND ACCESSORIES ON BOILER UNITS

Note: Jacket must be installed on boiler units prior to installation of trim.

- I. STEAM BOILER TRIM, see page 2 for tapping locations, and figure 4 for illustration of steam boiler.
 - A. Steam pressure gauge and pressure cut-out, install in tapping no. 4, figure 4.
 - B. Gauge glass set — use tapping no. 12.
 - C. Pop safety valve — use tapping no. 3, piped full size to boiler; or pipe full size into a valveless steam header.
 - D. Combustion safety control — mounted on burner.
- II. WATER BOILER TRIM, see page 2 for tapping locations, and figures 1 and 2 for illustration of water boiler.
 - A. Pressure- temperature - altitude gauge — use tapping no. 6.
 - B. High temperature limit — use tapping no. 7.
 - C. Operating control (if used) — use tapping no. 7.
 - D. Water relief valve — use tapping no. 3, piped full size to boiler.
 - E. Automatic air vent or compression tank tappings — if used, install in tapping no. 2.
 - F. Combustion safety control — mounted on burner.

PIPING

IMPORTANT: Boilers are to be used with closed system. Any application that uses steam or water from system, causes the introduction of a frequent supply of fresh water into the boiler. This will cause damage to the boiler. Use of heat exchangers will prevent this damage.

PIPING FOR STEAM BOILERS

Provide Header and Hartford Loop as suggested. See figures 4 and 5. Local codes apply.

CLEANING PIPING SYSTEM

- A. To clean piping system, open all valves at the heating elements. After getting up a good head of steam, shut the boiler down and allow the condensate to return to the boiler. The condensate will carry the oil film with it. Again blow-off the boiler. On extremely fouled systems, it may require several visits over a few days to clean the system.
- B. When steam only (no water) is released through the hand valve, the boiler will not surge or flood.

PIPING FOR WATER UNITS

NOTE: On knocked-down boiler only, jacket may be installed after supply and return piping connection, but must be installed prior to adding trim.

I. CIRCULATING SYSTEM

- A. FORCED CIRCULATION hot water heating system: Use the top tapping as supply tapping, and use the front or rear bottom tappings for the return.
- B. A FLOW CONTROL VALVE (See figure 6) will prevent gravity circulation and usually is required when tankless heater is installed.

II. AIR CONTROL SYSTEMS

- A. DIAPHRAGM-TYPE COMPRESSION TANKS are used to control system pressure in an AIR ELIMINATING SYSTEM: an automatic air vent is used to REMOVE air from the system water. See figure 6. If system pressure needs further control, add an additional tank or install a larger capacity tank. The automatic air vent should be installed in the top of the boiler, as in figure 6.
- B. CONVENTIONAL COMPRESSION TANKS (non-diaphragm type) are used to control system pressure in an AIR COLLECTING SYSTEM. Within the system, after initial start-up and venting, air is collected in the tank and acts in contact with the water to control pressure. Air is not vented from this system. If system pressure needs further control, add another tank in parallel with the original tank or install a large capacity tank. Locate the tank at the inlet end of the pump near the boiler. (See figure 7)

C. **HOT WATER RADIATION VENTING** - Manual air vents should be installed at the top of all "drops"(where piping goes downward).

Air must be vented or purged from all zone lines to permit proper system heating.

D. **PUMP LOCATION**-Locating low-head pump(s) on return to boiler is only acceptable in residences of one or two stories. (See figure 6) The pump location shown in figure 7 is required in large, multi-story building installations, especially when high-head pumps are used and is also recommended for all applications.

E. A conventional compression tank may be connected to the 3/4" tapping as shown in figure 7.

IMPORTANT: Hot water heating systems containing high water volume, such as would occur with cast-iron radiation, require special care with air elimination. The circulator pump should be located on the boiler supply pipe and the expansion tank and air scoop should be located near the pump suction. (See Figure 6, Alternate Pump Location.)

PIPING TANKLESS HEATER (if used)

I. Heater capacities are listed on Page 2.

II. Pipe the built-in tankless heater using the inlet and outlet tapings indicated on the heater (figure 8).

A. Tempering valve (illustrated, but not furnished) is suggested to provide more volume of temperate water to kitchen and bath.

B. High temperature water, for dishwasher and laundry, may be piped direct.

C. A flow control valve should be used to control the rate of flow of water through the coil, otherwise the heating capacity of the coil will be exceeded. To insure sufficient hot water, the flow rate through the coil should be limited to a maximum shown for intermittent draw in the ratings table on page 2.

IMPORTANT: Escape pipes or drain pipes from relief valves, safety valves, blow-down valves, and low-water cut-off must be piped off to a safe place.

INSTALLING THE BURNER

See Burner Data, pages 14-18, and Burner Manual supplied with burner. If burner is not mounted as received, mount to boiler, placing flange over mounting studs. Use gasket between flange and boiler. Distance between flange and nose of burner must be as shown on pages 14-18. Check to see that nozzle and settings are as given in burner data tables, pages 14-18.

CAUTION: DO NOT USE GASOLINE, CRANKCASE DRAININGS, OR ANY OIL CONTAINING GASOLINE.

OIL SUPPLY PIPING

Install the oil tank or tanks and piping from tank to burner. Follow local codes and practices, NFPA No. 31, **INSTALLATION OF OIL BURNING EQUIPMENT** and the instruction sheet attached to the oil burner pump. A one-pipe system should be used for gravity-fed fuel systems and for lift systems, where the total lift is less than 8 feet. Where the total lift is greater than 8 feet, a two-pipe system must be used. In some instances, local codes may require a two-pipe system for below grade fuel oil tanks. Be sure to set-up the fuel oil pump for the piping system used; follow the instructions attached to the pump. Be sure to include a good quality, low pressure drop fuel oil filter in the supply line from the tank. This is necessary, especially at low fuel oil flow rates (small nozzle sizes), to prevent nozzle plugging. See Slant/Fin publication on one-pipe and two-pipe fuel oil systems.

WIRING THE BOILER

A. The wiring diagrams for the burner and boiler may be found on pages 11-13.

B. 24 volt control wiring should be approved Safety Circuit wire, protected as needed.

C. Power supply wiring to the burner must be 14 gauge or heavier, as required, and should have a properly fused disconnect switch. 120 volt wiring to pumps and safety controls must also be 14 gauge or heavier. Wire must be enclosed in approved conduit.

D. All wiring must be installed in compliance with the National Electric Code, or any local or insurance codes having jurisdiction.

Wiring to the boiler must come through an emergency power isolation switch with a clearly marked red switch plate. This switch should be located so that it is apparent to the homeowner when entering the basement or other boiler area. The homeowner should be made familiar with operating the toggle to provide or stop the power to the boiler.

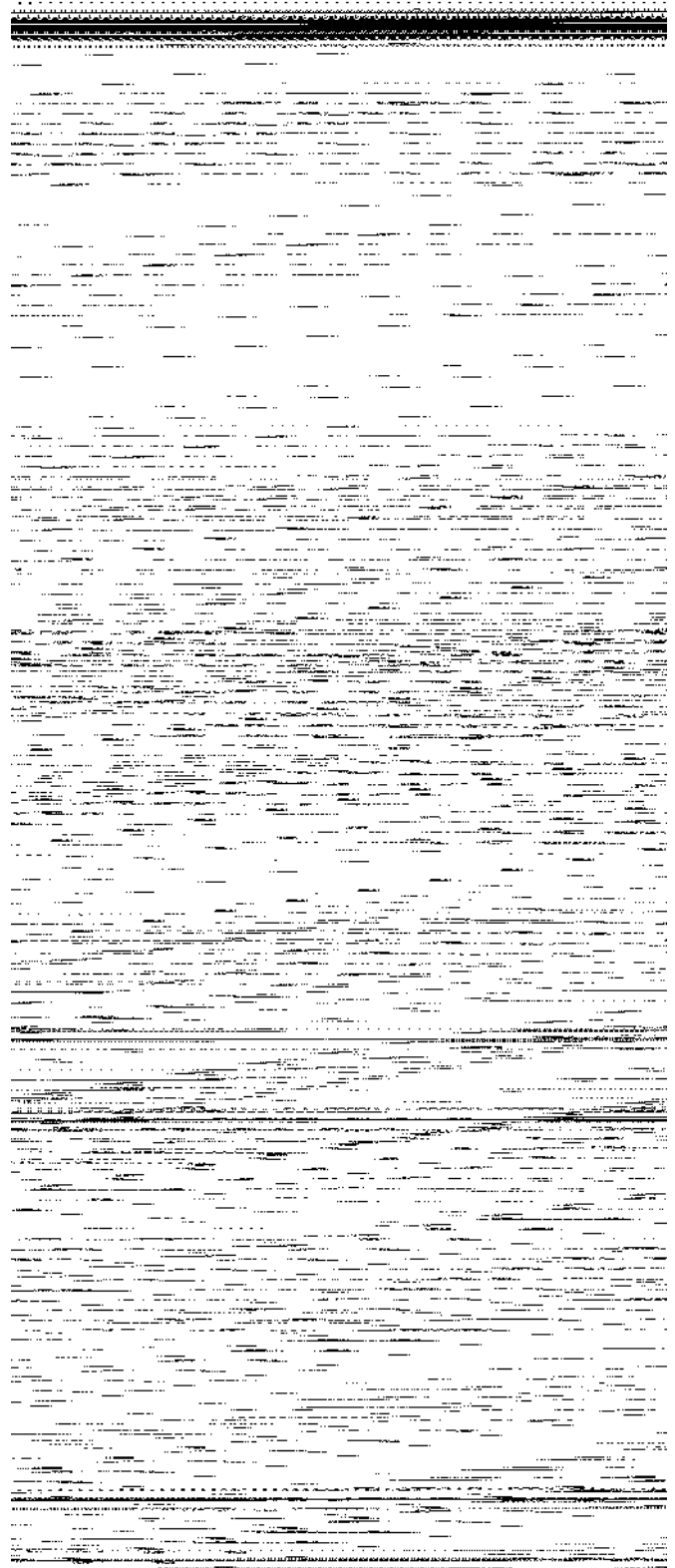

VENT PIPING AND DRAFT REGULATOR

- A. Vent pipes must be installed having the same diameter as the boiler outlet. (See page 2)
- B. Vent pipes and breeching must be pitched upward a minimum of 1/4" per foot.
- C. Connect vent pipe to the chimney using as few elbows as possible.
- D. Horizontal vent connector into the chimney should not be inserted beyond the inside wall of the chimney.
- E. Install barometric draft regulator on horizontal breeching, near chimney, with hinge horizontal and face vertical. See manufacturer's instructions packed in carton with barometric draft regulator.
- F. If two or more appliances are used on the same chimney, see CHIMNEY, page 3.
- G. Make up all joints with minimum air leaks, secure with sheet metal screws.

OPERATING INSTRUCTIONS**PRECAUTIONS BEFORE STARTING OIL BURNER**

Make a positive check of A through F before starting burner:

- A. Boiler and system are full of water. All air is vented from system. See below.
- B. All wiring is completed. See pages 11-13.
- C. Oil supply is connected to the burner; nozzle is installed correctly; oil valve is open at tank.
- D. Smokepipe is connected to chimney.
- E. All combustible materials are cleared away.
- F. Combustion air supply is provided. See page 3.
- G. Burner settings are adjusted as per pages 14-18 and as shown on boiler jacket.
- H. Main cast-iron door on which burner is mounted is bolted shut and fiberglass rope seal is making good contact.

CAUTION: DO NOT START THE BURNER UNLESS ALL CLEANOUT DOORS ARE SECURED IN PLACE.

WARNING: NEVER OPERATE any natural draft* boiler (Liberty II boiler is a natural draft boiler) with zero draft or overfire pressure: early failure of the burner, nozzle and chamber is inevitable if you do. Use a draft gauge, and make sure that overfire draft* is .02", minimum, during all operating conditions.

* Draft is negative or suction pressure.

START-UP (COMBUSTION TEST INSTRUMENTS MUST BE USED)

- A. Make sure the boiler is installed and wired properly and is full of water.
- B. Open the observation door (on the front, above the burner).
- C. Start the oil burner (see burner instructions for bleeding air from oil, etc.). IMMEDIATELY, set burner air bands to obtain a bright fire without smoke or oil stain. Set the DRAFT REGULATOR to obtain .02" overfire draft*. Take draft reading through slot in observation door.
- D. Close the observation door. Allow the burner to fire for at least one hour total firing time, to bake out the volatile binders in the combustion chamber before taking final combustion readings.
- E. By alternate adjustment of the barometric draft regulator, the burner air regulation and head regulation devices (whichever apply), set for a trace of smoke and as close to 13% CO₂ as you can. Then open the air bands or shutter (whichever apply) an additional 1/8". This should result in zero smoke with NO raw oil on the smoke paper and a smooth light-off. DO NOT ATTEMPT TO SET FIRE BY EYE. Flame retention burners may appear efficient and smoke free from an inefficient 7% up to an overly high 14% CO₂. However, a very low CO₂ can also result in poor ignition and raw (unburned) oil entering the fire box. At very high CO₂, any slight decrease in air flow for any reason will cause incomplete combustion, with high smoke and dry soot formation in the fire box.
- F. If smoke reading is satisfactory, but CO₂ can not be increased to a satisfactory level (12% or better) or overfire draft of 0.02" W.C. can not be obtained, check for proper sealing between sections, between burner mounting plate and front section, around burner blast tube and around flue collector and collar. If seal is not satisfactory, reseal with furnace putty or silicone with a temperature rating of at least 400° F. (All safety precautions indicated on material package must be followed.)

G. Once burner and draft have been set up, then smoke, CO₂ and stack temperature should be checked and recorded. If smoke is greater than trace, review the burner instructions; replace the nozzle if necessary. Normal smoke to be expected at approximately 13% CO₂ is zero to a trace.

CLEANING AND FILLING A NEW WATER BOILER

- I. There are a number of commercial preparations available from your distributor for cleaning and for corrosion protection conditioning the internal (waterside) surfaces of boilers. Follow the preparation manufacturer's instructions.

DANGER: Use CAUTION when handling chemicals and draining hot water from a boiler. Scalding water and/or chemicals can cause permanent injury to the skin, eyes and respiratory system.
- II. Filling and venting the water boiler after cleaning
 - A. Refill the system with fresh water.
 - B. Bring water temperature to at least 180° F promptly.
 - C. Circulate water through entire system.
 - D. Vent the system, including the radiation.
 - E. The boiler is now ready to be put into service or on standby.
 - F. If brand name air-control devices are used, venting instructions furnished with the devices should be followed.
- III. Safety check for control system

High limit control test: Set thermostat high enough for boiler water temperature to reach high limit control setting. When this temperature is reached, the high limit switch should open, and the burner should shut off automatically. If the high limit does not operate to shut off the burner, the high limit or the wiring is faulty. Repair or replace immediately.

CLEANING AND FILLING A NEW STEAM BOILER

I. BEFORE USING STEAM BOILER

- A. Check burner to be certain it is ready for firing. DO NOT FIRE into an empty boiler.
- B. Be prepared to heat raw water to at least 180°F. as soon as it is introduced into the boiler. This procedure will remove dissolved, corrosive gases.
- C. Provide drain line, with valve, from boiler. Use a bottom tapping. Line and drain must be suitable for handling caustic solution.
- D. Check for low water cut-off operation, see section below for check-out.

II. CLEAN STEAM BOILER SYSTEM.

- A. Fill the boiler to water line indicated on the boiler.
- B. Follow start-up procedure for burner and operate the boiler with steam in the entire system for 2 or 3 days to bring oil and dirt from the system to the boiler. While system is in operation, maintain the proper water level in the boiler by slowly adding water to the boiler.
- C. Shut down burner, cool down boiler and drain system.
- D. Procedure to dissolve oil and grease in boiler:
 1. Fill boiler to proper water line.
 2. Prepare a boil-out solution of *sodium hydroxide* (caustic soda) and *tri-sodium phosphate*:
NOTE: Use caution in handling chemicals. Caustic soda is harmful to skin, eyes and clothing.
(a) Proportions: 1 lb. of each chemical per 50 gallons of system water.
(b) Stir chemicals into water until dissolved and pour into the boiler through a top tapping. Replace plug.
 3. Start the burner; boil the water for at least 5 hours; shut off the burner.
- E. With CAUTION, drain the boiler solution to a safe location. DO NOT LEAVE SOLUTION SITTING IN SYSTEM OVER 2 HOURS.
- F. Wash the water side of the boiler thoroughly using a high pressure water stream. Fill and drain the boiler several times.

III. TREATING WATER FOR CORROSION CONTROL

(This is not scale control)

- A. Prepare a solution of *sodium chromate*.
Proportions: 1 lb. per 50 gallons of boiler water.
- B. Stir chemical in water until dissolved and pour into boiler through a top tapping. Replace plug.

IV. FILLING AND VENTING THE STEAM BOILER

- A. Refill the boiler to the indicated water line.
- B. Bring water to boiling temperature, promptly.
- C. The boiler is now ready to be put into service or on standby.

BLOWING OFF A LOW PRESSURE STEAM BOILER

- A. A 1-1/2" NPT tapping is provided in the front of the boiler (tapping no. 9, figure 1) for use as a surface blow down to provide rapid skimming of oil and grease which accumulate on the surface of the water. The boiler should be blown down as outlined below.
- B. Turn off electrical power supply to boiler. Allow boiler to cool down and steam pressure to reduce to zero before removing skimmer tapping plug. Check for steam pressure by testing the pop safety valve. Keep your hands and all parts of your body away from the discharge end of the safety valve. Drain boiler down one to two inches below skimmer tapping. The water might be hot. Remove skimmer plug slowly and carefully install a 150 psi malleable iron 1-1/2" NPT street elbow, a 1-1/2" NPT skimmer valve and length of pipe and place a bucket underneath the open end of the pipe. Cover bucket with a piece of cloth. (See figure 9)
- C. Fill boiler slowly until water level is two inches from top of gauge glass. (This is the starting water level for skimming only.) Fire boiler to produce steam. If the system is heavily laden with oil, it may be difficult to obtain much more than a pound or so of pressure. Set the pressure control at about 7 psi. The higher the steam pressure you can use, the better and faster the cleaning.

- D. As steam develops, open the SKIMMER drain valve with caution to skim the oil and film from the top of the water. DO NOT open the boiler drain valve. Close the skimmer drain valve when the water level drops to about 5" from the top of the gauge glass. The water may stop before the level drops to 5" below the top of the glass. Refill boiler until water level is again two inches from the top of the gauge glass.
- E. Repeat (D) above until all film is skimmed off and the water settles to a normal movement. Add make up fresh water to the boiler as described in (D) above, during the blow-off operation, to maintain the proper skimming water level in the vessel. Empty bucket frequently in order to see the difference in water cleanliness.
- F. When surging has stopped and water is clean, and no film can be seen floating in the bucket, shut off boiler, drain down to level of skimmer tapping, remove valve, plug skimmer tapping and refill the boiler to 24-1/2" water level. After 15 minute operation, readjust level to normal operating level of 25-1/2" from bottom of boiler (see figure 9). Check the pop safety valve for proper operation. Check the low water cut-off operation, see below.
- G. The entire process may have to be repeated over a period of a few days on extremely fouled systems.

LOW WATER CUT-OFF CHECK-OUT

I. Electronic probe type low water cut-off

If this boiler is factory equipped with an electronic probe type low water cut-off, operation of cut-off should be checked at least twice a year as follows:

- A. While boiler is running, drain down boiler water slowly through Boiler Drain Cock shown on page 4, just until light goes on. Boiler should shut down 10 seconds after light goes on.
- B. Be sure that it is the low water cut-off and not the room thermostat, pressure cut-out, or other control that has shut off the burner.
- C. Refill the boiler and repeat test.
- D. Refill the boiler and reset controls for normal operation.

II. Float type low water cut-off

If this boiler is factory equipped with a McDonnell & Miller float type low water cut-off, the low water cut-off must be blown down (flushed), at least once a week.

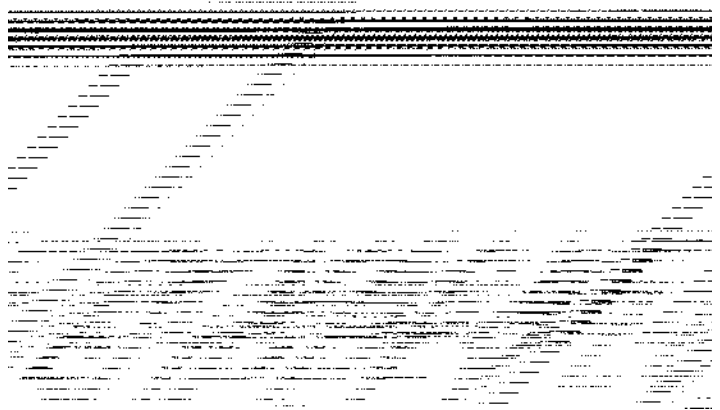

CAUTION: When flushing float type low water cut-off control, hot water and steam will flow out the blow down valve. Blow down valve is illustrated below.

A. SPECIAL FLUSHING INSTRUCTIONS

For new boiler installed in old system.

Installation of new boiler may break loose a heavy accumulation of sediment and scale from old piping and radiators. It is extremely important to blow down your McDonnell cut-off more frequently the first week.

First week — 3 times

Thereafter — at least once a week.

- B.** As boiler water circulates through the float chamber, dirt or other sediment may be deposited. This chamber is extra deep. But the only sure way to keep any accumulation from interfering with float action is to "blow down", or flush out, the control once a week. Do it while boiler is in operation. First note water level in gauge glass. Open blow-off valve at bottom of control; water will pour out, flushing away sediment. Drain until water is clear — about a pail — then close valve. If level in gauge glass has dropped, add water to boiler to restore level.
- C. NOTE:** Opening blow-off valve checks cut-off operation too. As float drops with falling water level, burner will stop. After burner is off and normal operating conditions restored, burner will resume firing.
- D.** Be sure that it is the low water cut-off and not the room thermostat, pressure cut-out, or other control that has shut off the burner.

PRESSURE CONTROL CHECK-OUT

- A.** Check burner to be certain it is ready for firing. **DO NOT FIRE** into an empty boiler.
- B.** Set thermostat high enough for boiler to make steam. Set the pressure control down to its lowest setting. As the boiler starts to produce steam, the steam pressure will start to build. The burner will shut off when the steam pressure exceeds the pressure setting (plus differential if control has this feature).
- C.** Adjust the pressure control to a higher setting. The higher setting should be above the steam pressure in the boiler. This should turn the burner back on.
- D.** Reset the pressure control as needed for the system. The pressure control should be checked at least twice a year.

REPLACEMENT OF STEAM BOILERS

Anytime an older steam boiler is removed from the heating system and replaced with a new boiler, there are certain conditions that have to be examined on the heating system.

- A.** Steam systems have a tendency to develop scale inside the wet return lines and the boiler. The older the system the greater the accumulation of scale that can exist inside the piping. Therefore, it is necessary when replacing a steam boiler to check the piping for blockage or restrictions. Clean or replace the piping as required. (See special flushing instructions on this page.)
- B.** Replace all buried wet return lines.
- C.** All equipment (air vents, radiation equipment, etc.) in the steam heating system should be checked for proper operation. All piping should be checked for proper pitch.
- D.** It is good engineering practice to repack or tighten the packing nuts on all valves in the heating system.

BASIC WIRING DIAGRAMS
 (without tankless heater)
 OR
 (with tankless heater)

L8148A OR L7248L
 OR
 L8124 OR L7224
 OR
 OPTIONAL HYDROSTAT MODEL 3150

15 AMP. MAXIMUM
 OVERCURRENT
 PROTECTION DEVICE

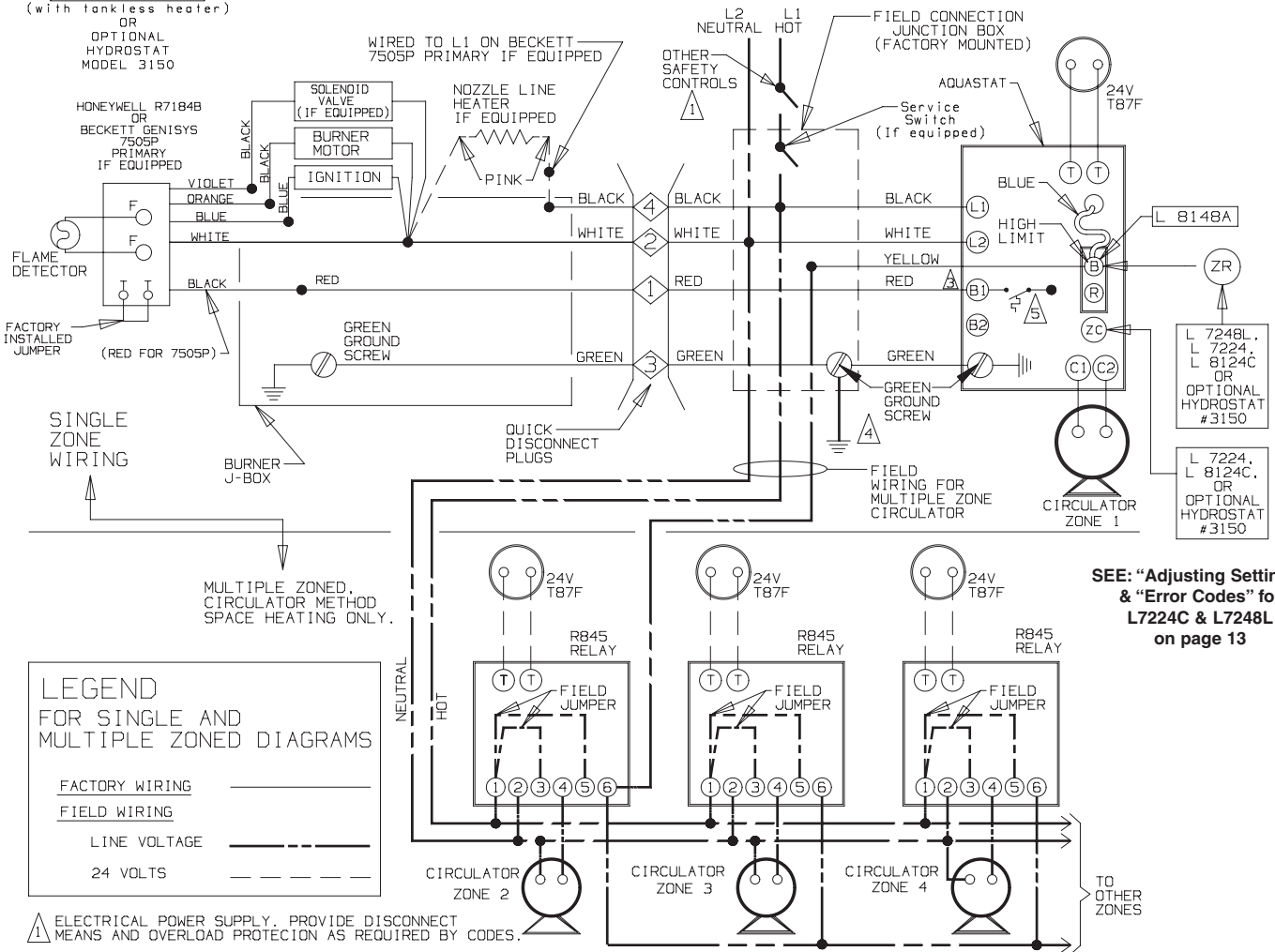

SEE: "Adjusting Settings" & "Error Codes" for L7224C & L7248L on page 13

LEGEND FOR SINGLE AND MULTIPLE ZONED DIAGRAMS

FACTORY WIRING	—————
FIELD WIRING	- - - - -
LINE VOLTAGE	—————
24 VOLTS	—————

- ⚠ ELECTRICAL POWER SUPPLY. PROVIDE DISCONNECT MEANS AND OVERLOAD PROTECTION AS REQUIRED BY CODES.
- ⚠ CONTROL CASE MUST BE CONNECTED TO EARTH GROUND. USE GROUNDING SCREW PROVIDED.
- ⚠ B1 IS 1/4 IN. TAB TERMINAL.
- ⚠ GROUNDING CONDUCTOR: TWO GREEN GROUND WIRES ARE FACTORY CONNECTED TO THE GREEN GROUND SCREW IN THIS BOX. FIELD WIRE A GROUND CONDUCTOR TO THIS SCREW TOGETHER WITH THE TWO GREEN FACTORY CONNECTED GREEN GROUND WIRES.
- ⚠ OPTIONAL HYDROSTAT MODEL 3150 IS EQUIPPED WITH AN INTERNAL LOW WATER CUT-OFF.

ZONE WIRING DIAGRAM CIRCULATOR METHOD FOR L8124, L7224 OR OPTIONAL HYDROSTAT #3150 CONTROLS. (FOR TANKLESS HEATER APPLICATIONS)

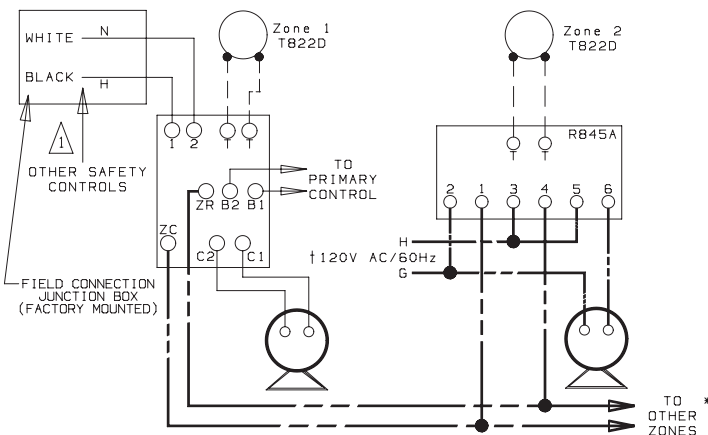

*Note: Total load not to exceed 8 amp full load, for circuits shown.

MULTIPLE ZONED, ZONE VALVE METHOD USING HONEYWELL V8043F OR ERIE 765

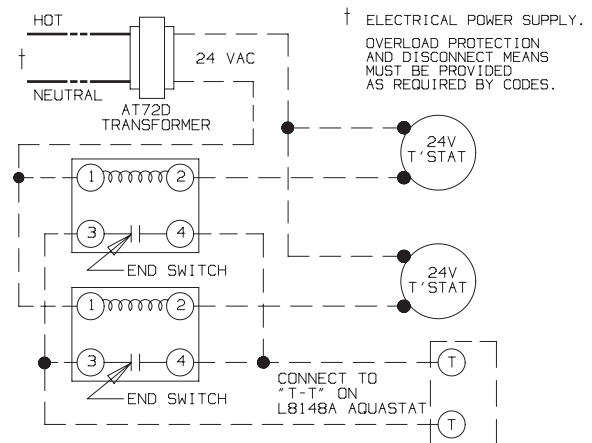

FOR L7224C OR L7248L

ADJUSTING SETTINGS

To discourage unauthorized changing of Aquastat settings, a procedure to enter the ADJUSTMENT mode is required. To enter the ADJUSTMENT mode, press the UP, DOWN, and I buttons simultaneously for three seconds. Press the I button until the feature requiring adjustment is displayed:

- . HL_ . High Limit.
- . LL_ . Low Limit. (L7224 only)
- . Ldf . Low Limit Differential. (L7224 only)
- . °F . °C.
- . ELL_ External Low Limit (L7248L only)

Then press the UP and/or DOWN buttons to move the set point to the desired value, to change between °F and C°, or to enable (On) or disable (Off) the External Low Limit. After 60 seconds without any button inputs, the control will automatically return to the RUN mode.

DISPLAY

In the RUN mode, the Aquastat will flash .bt. (boiler temp) followed by the temperature (i.e., 220), followed by °F or °C.

To read boiler settings, press the I key to read the parameter of interest. For example, press I High Limit (HL) is displayed, followed by a three-digit number, i.e., 220, followed by

°F or °C. Pressing the I button again (on L7224 models) will display the Low Limit (LL) followed by a three-digit number and the corresponding degree designator.

After approximately 60 seconds without any key presses, the display will enter a dim display mode. To return to the bright display mode, simply press any key.

DESCRIPTION

- Boiler Temperature – bt
- High Limit – HL
- Low Limit – LL
- Low Limit Differential – Ldf
- Local Thermostat Status – tt
- EnviraCOM Thermostat Status – tte
- Error Code – Err
- Degrees Fahrenheit – °F
- Degrees Celsius – °C

Aquastat Error Code	Cause/Action	EnviraCOM Alarm
Err1	Aquastat sensor fault; check water sensor.	18
Err2	E COM fault; check EnviraCOM™ wiring.	18
Err3	Excessive electrical noise or frequency out of range. Hardware fault; replace controller.	18, 58
Err4	B1 fault; check B1 wiring/voltage.	64
Err5	Low Line; check L1-L2, 110 Vac.	59
Err6 ^a	Warning: Fuse; check E COM wires, replace fuse.	92
Err7	Warning: EEPROM, HL, LL, Hdf, Ldf; reset to default values.	N/A
Err8 ^b	Repeated B1 fault (voltage present at B1 when output is turned off); check B1 wiring/voltage.	25
Err9 ^a	Warning: Outdoor Reset System failure; communication to Outdoor Reset Module lost, Outdoor Reset Module failure, multiple outdoor temperature sensors detected on the bus, or outdoor temperature sensor failure. Check EnviraCOM wiring (1, 2, 3), check sensor wiring.	50, 53, 149
Err10 ^a	Warning: Boost Failure; Boost Mode active at least once per cycle for the last 60 consecutive cycles. Check Outdoor Reset curve settings.	150
Err11 ^a	DHW Module/Sensor failure; communication to DHW Module lost, DHW Module failure, or temperature sensor failure. Check EnviraCOM wiring (1, 2, 3), check sensor wiring.	146, 147, 148

^a Warnings are generated to enunciate the system is not operating optimally, but the Aquastat is still operating and maintaining boiler temperature. In the instance where an Outdoor Reset Module is used, the warnings may indicate a reset curve setting error one or more features is not running optimally, and the Aquastat is reverting to default settings or has stopped running the Outdoor Reset algorithms. The warnings are cleared when the issue(s) is resolved.

^b To clear Err 8 condition, depress and hold all three user keys simultaneously for 60 seconds. Err 8 condition clears and display returns to normal. Err 8 condition is designed to catch welded relays on the Aquastat and will normally only occur near end of life for the control. If Err 8 condition has occurred early in the controls life, be sure to check for voltage feedback to B1 when B1 should be off and check current draw on b terminal to be sure oil burner is not drawing excessive current. Err 8 condition will keep repeating if B1 fault is not cleared.

BASIC WIRING DIAGRAMS

L7224C OR L8124C OR A
(WITH TANKLESS HEATER)

NOTES:

1. RECOMMENDED HIGH LIMIT SETTING IS 200°F. LOW LIMIT MUST BE SET AT LEAST 20°F BELOW HIGH LIMIT SETTING.
 2. PUMP ZONING TERMINALS ZR AND ZC FURNISHED ON L8124 AND L7224C CONTROLS. SEE PUMP ZONING DIAGRAM BELOW
- † OVERLOAD PROTECTION AND DISCONNECT SWITCH MUST BE PROVIDED AS REQUIRED BY LOCAL CODES.

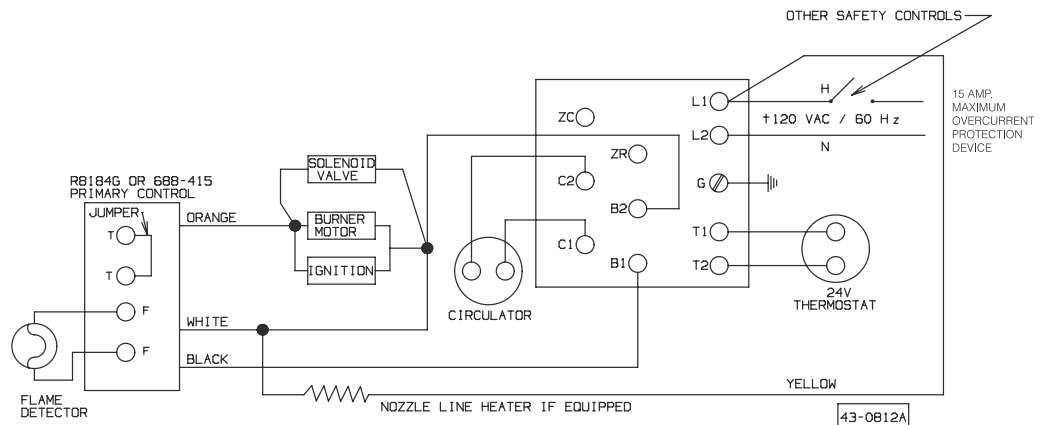

**BASIC MODULE WIRING
(less circulator)**

See Detail "A" (p.13) for primary other than R7184

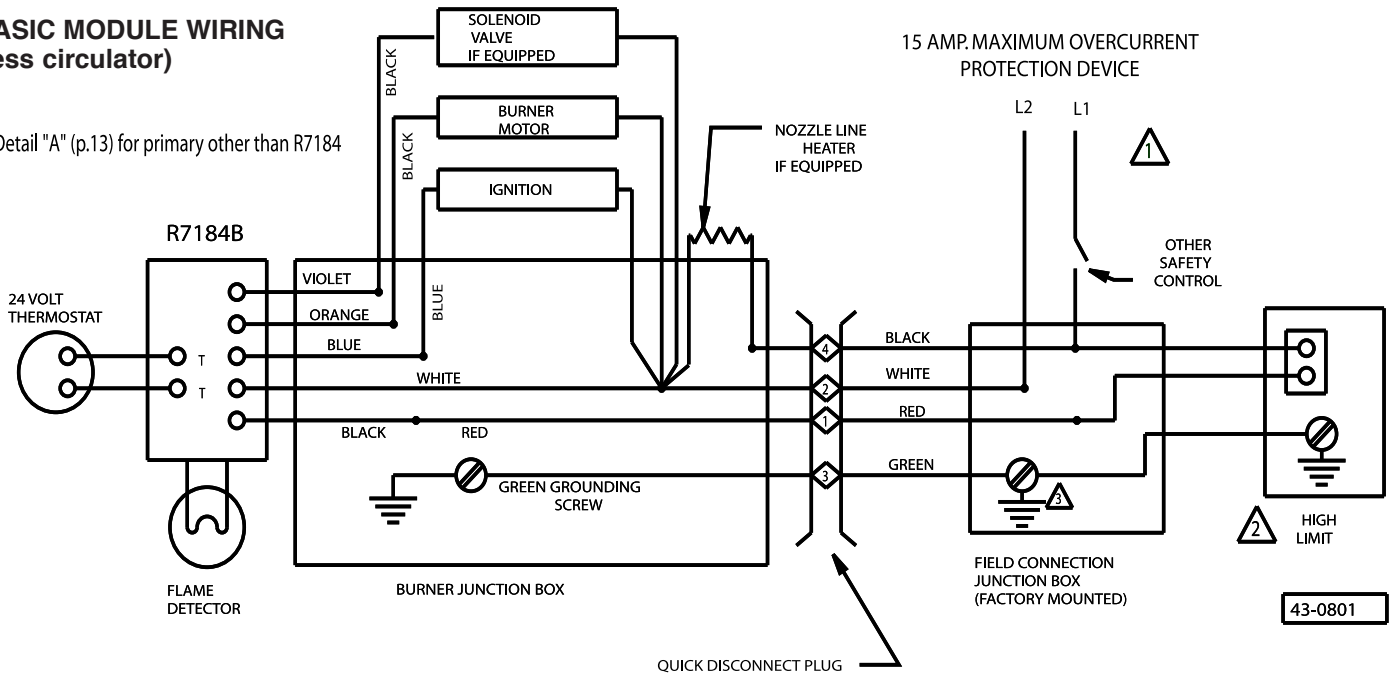

- ⚠ ELECTRICAL POWER SUPPLY PROVIDE DISCONNECT MEANS AND OVERLOAD PROTECTION AS REQUIRED BY CODES.
- ⚠ CONTROL CASE MUST BE CONNECTED TO EARTH GROUND USE GROUNDING SCREW PROVIDED.
- ⚠ GROUNDING CONDUCTOR: TWO GREEN GROUND WIRES ARE FACTORY CONNECTED TO THE GREEN GROUND SCREW IN THIS BOX. FIELD WIRE A GROUNDED CONDUCTOR TO THIS SCREW TOGETHER WITH THE TWO GREEN FACTORY CONNECTED GREEN WIRES.

WIRING FOR PACKAGED STEAM BOILER EQUIPPED WITH McDONNELL NO.67 L.W.C.O.

High-Pressure Limit
Recommended setting 0.5 PSI
Differential 5 PSI

Low Limit (tankless model only)
recommended setting 160°F

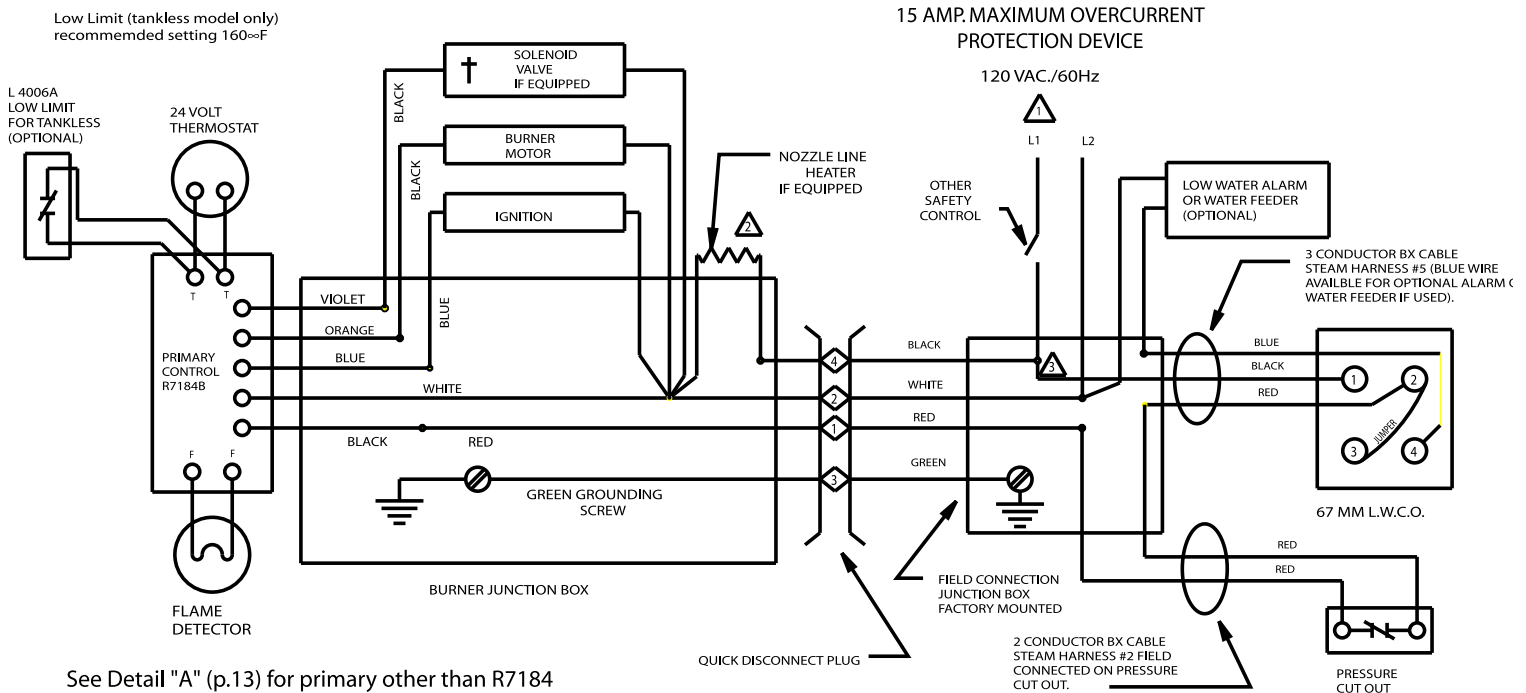

See Detail "A" (p.13) for primary other than R7184

- † Solenoid valve if equipped.
- Splice
- Terminal
- ⚠ Overload protection and disconnect switch must be provided as required by local codes.
- ⚠ Nozzle line heater, if equipped.
- ⚠ On burners without nozzle line heater, field connect hot line to single black wire from 3 conductor box cable in 4 x 4 junction box.

WIRING FOR PACKAGED STEAM BOILER

For alternate option PS-801-120 L.W.C.O.
or Hydrolevel Cycle Gard 450 L.W.C.O.

High-Pressure Limit
Recommended setting - 0.5 PSI
Differential - 5 PSI
Low Limit (Tankless Model Only) Recommended setting - 160°F.

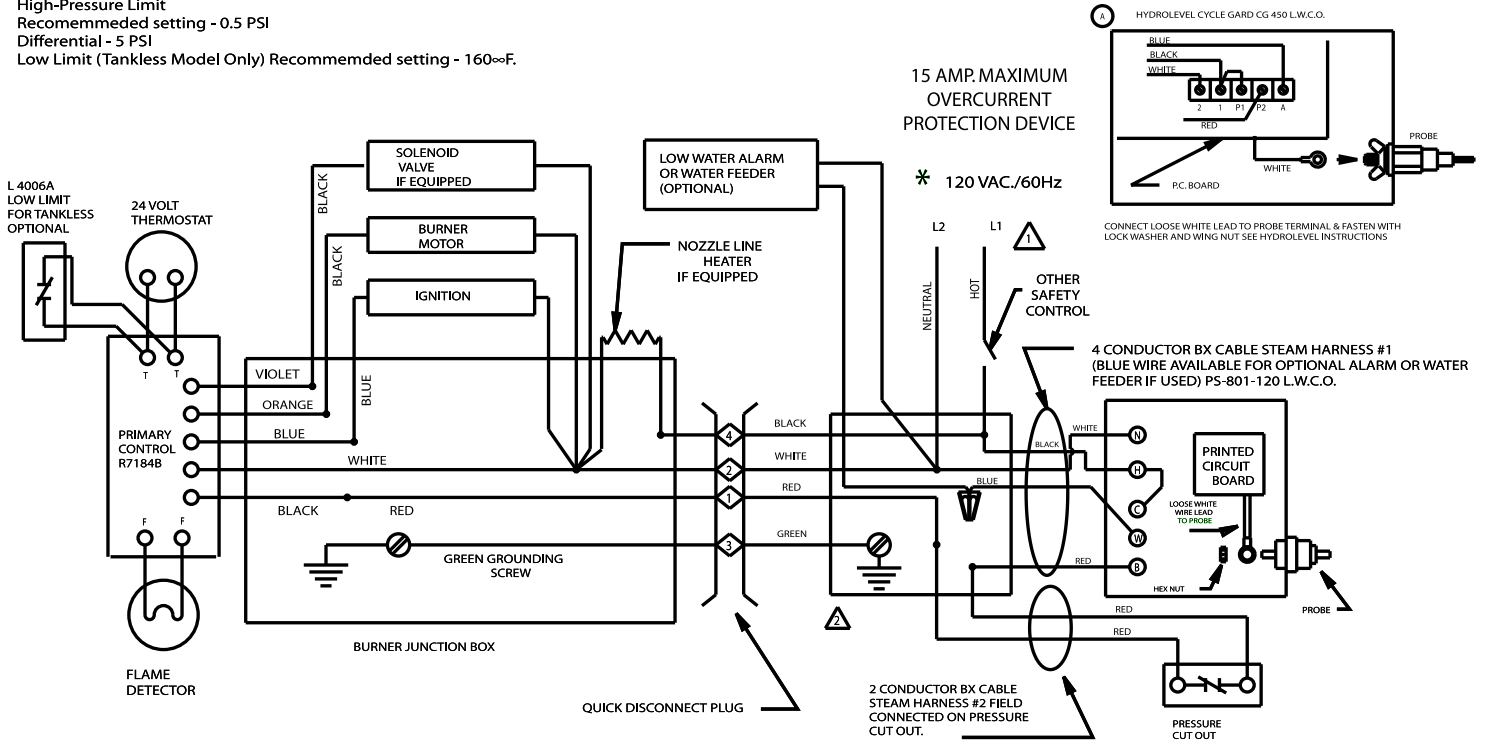

See Detail "A" for primary other than R7184

- * OVERLOAD PROTECTION AND DISCONNECT SWITCH MUST BE PROVIDED AS REQUIRED BY LOCAL CODES.
- ⚠ ELECTRICAL POWER SUPPLY. PROVIDE DISCONNECT MEANS AND OVERLOAD PROTECTION AS REQUIRED BY CODES.
- ⚠ GROUNDING CONDUCTOR: GREEN GROUND WIRES ARE FACTORY CONNECTED TO THE GREEN GROUND SCREW IN THIS BOX. FIELD WIRE A GROUNDED CONDUCTOR TO THIS SCREW TOGETHER WITH THE GREEN FACTORY CONNECTED GREEN WIRES.

Detail "A"

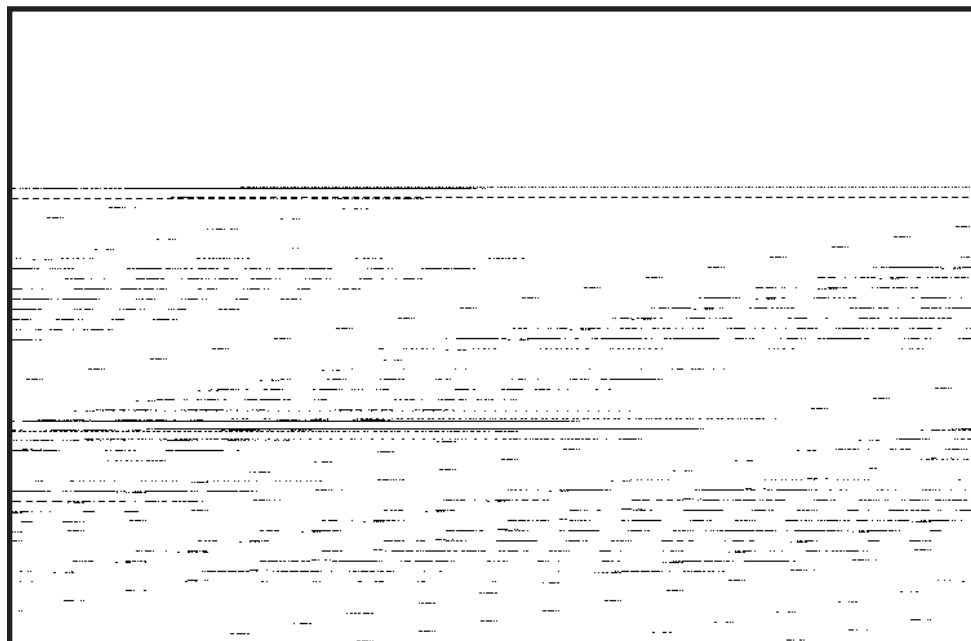

BURNER DATA — BECKETT AFG BURNERS FOR PACKAGED BOILERS ONLY

(For knocked-down & boiler burner units see publication no. L-42KB)

BOILER MODEL	BURNER MODEL *	BURNER HEAD	FIRING RATE (GPH)	NOZZLES			OIL PUMP PRESSURE SETTING (PSIG)	APPROX. AIR SHUT-TER SETTING NO. †	APPROX. AIR BAND SETTING NO. †
				SIZE (GPH)	ANGLE & TYPE	MFR.			
LD-20	AFG-SF-11-03	F0	.75	.75	80° B	DELAVAN	100	8	CLOSED
LD-30	AFG-SF-11-07	F4S	1.00	1.00	80° SS	HAGO	100	8	CLOSED
					80° A	DELAVAN			
					80° W	DELAVAN			
			1.10	1.10	80° ES	HAGO	100	9	CLOSED
					80° W	DELAVAN			
					80° ES	HAGO			
1.25	1.25	80° W	DELAVAN	100	10	1/2			
		80° ES	HAGO						
		80° W	DELAVAN						
LD-40	AFG-SF-11-02	F120	1.60	1.50	80° ES	HAGO	113	10	1-1/4
					80° B	DELAVAN	113		
			1.80	1.75	80° SS	HAGO	105	10	3
					80° B	DELAVAN			
LD-50	AFG-SF-11-05	F164	2.10	2.00	80° P	HAGO	110	10	1-1/2
					80° W	DELAVAN			
			2.35	2.25	80° P	HAGO	109	10	3-1/2
					80° W	DELAVAN			

† Air shutter and air band settings shown are approximate ONLY.

See START-UP page 8.

* All burner models shown are single stage.

NOTE: 1. Extended heads on all units, except model LD-20

2. No static plate for LD-50 only.

3. Insertion depth 2⁵/₃₂ for LD-30 and LD-40; 2²¹/₃₂ for LD-50.

Insertion depth 1²³/₃₂ for model LD-20.

4. Air Band: 2 slot for LD-30, 4 slot for LD-40, 8 slot for LD-50.

5. Burner may be equipped with a prepurge control.

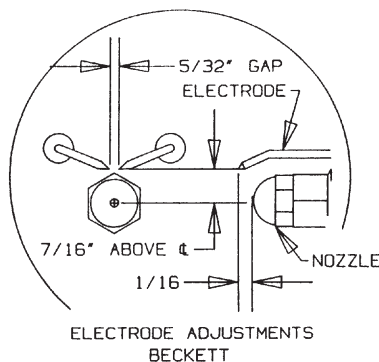
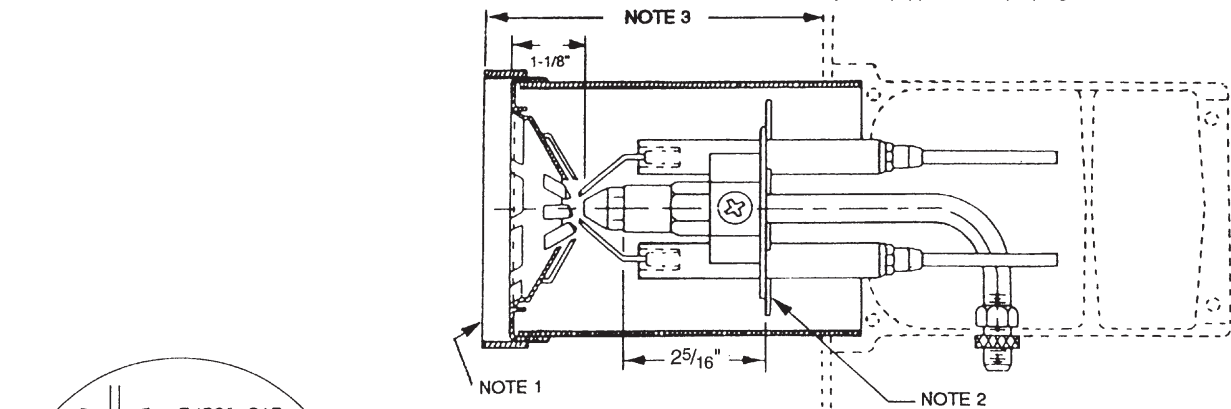

See table for approximate settings.

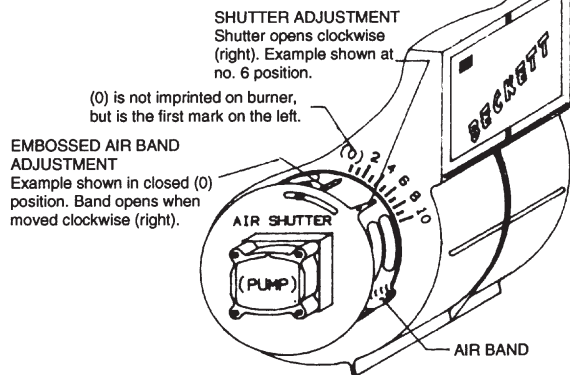

BURNER DATA – BECKETT CF-375 BURNERS FOR PACKAGED BOILERS ONLY

(For knocked-down & boiler burner units see publication no. L-42KB)

Boiler Model	Burner Model *	Nozzles				MFG	Oil Pump Pressure Setting (PSIG)	Air Shutter Setting †	Air Band Setting	Head Setting
		Firing Rate (GPH)	Size (GPH)	Angle & Type						
LD-60	CF-375	2.60	2.25	45° P		HAGO	135	10	3	1
LD-60	CF-375	2.85	2.25	45° P		HAGO	160	10	2	2
LD-70	CF-375	3.00	2.5	45° SS		HAGO	145	10	4	3
LD-70	CF-375	3.10	2.5	45° SS		HAGO	155	10	4	4
LD-70	CF-375	3.35	2.75	45° B		DELEVAN	148	10	4	5

† Air shutter and air band settings shown are approximate ONLY.
See START-UP page 8.

* All burner models shown are single stage.

BURNER DATA — RIELLO BURNERS FOR PACKAGED BOILERS ONLY

(For knocked down & boiler burner units see publication no. L-42KB)

BOILER MODEL	BURNER MODEL *	BURNER DESCRIPTION	FIRING RATE NO.2 OIL (GPH)	NOZZLES			OIL PUMP PRESSURE SETTING (PSIG)	APPROX. AIR SHUTTER SETTING NO.†	APPROX. HEAD SETTING NO.†
				SIZE (GPH)	ANGLE & TYPE	MFR.			
LD-30H	40 Series F-5	with short tube	1.00	.75	60° ES	HAGO	178	2.40	0
LD-30HF	40 Series F-5	with short tube	.95	.75	60° ES	HAGO	160	2.20	0
LD-30	40 Series F-5	with short tube	1.10	.85	70° ES	HAGO	160	4.50	2
					70° B	DELAVAN			
			1.25	1.00	70° ES	HAGO	160	4.00	2
					70° W	DELAVAN			
LD-40H	40 Series F-10	with short tube	1.50	1.25	70°B	DELAVAN	145	2.00	0
LD-40	40 Series F-10	with short tube	1.60	1.25	60° ES	HAGO	160	2.50	1
					70° B	DELAVAN			
			1.80	1.35	70° ES	HAGO	180	3.00	1
					70° B	DELAVAN			
LD-50H	40 Series F-10	with short tube	2.00	1.50	45° B	DELAVAN	178	3.00	1
LD-50HF	40 Series F-10	with short tube	1.90	1.50	45°B	DELAVAN	160	2.60	1
LD-50	40 Series F-10	with short tube	2.10	1.65	60° W	DELAVAN	160	4.00	2
			2.35	1.75	60° W	DELAVAN	170	4.00	4

† Air shutter and head settings shown are approximate ONLY. See START-UP page 8.

* All burner models shown are single stage.

NOTE: For proper insertion into combustion chamber see figure 12.

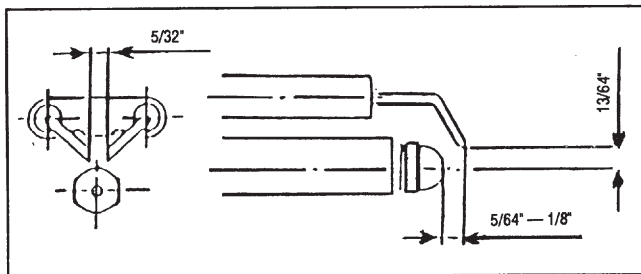
Figure 9A Riello 40 Series**MODEL F-5
ELECTRODE SETTING**

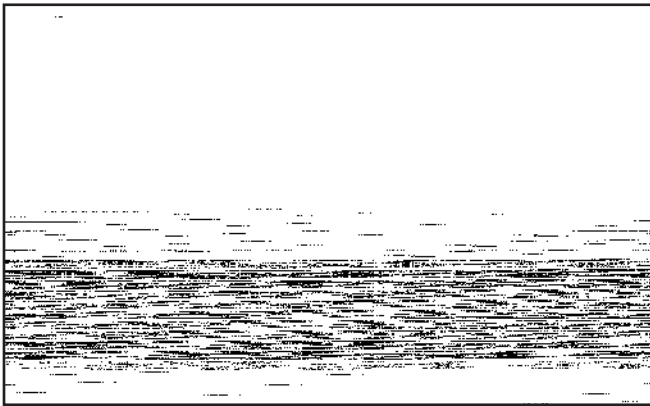
BURNER DATA – RIELLO (continued)**Figure 9B****MODEL F-10
ELECTRODE SETTING**

NOTE: ELECTRODES ARE PRESET AT THE FACTORY.

REGULATION OF THE TURBULATOR AND AIR SHUTTER FOR PROPER COMBUSTION**Turbulator Setting**

1. Loosen nut, 1, then turn the screw, 2, until the index marker, 3, is aligned with the correct index number.
2. Retighten the retaining nut, 1.

TURBULATOR SETTINGS - RIELLO 40 SERIES

The numbers on the casting are there to denote the high and low end of the scale — in all cases the first mark if "Zero".

The air/oil ratio depends on accurate setting of the turbulator disc.

Be careful when making this adjustment as an incorrect setting will result in an unsatisfactory installation. See figures 10A and 10B.

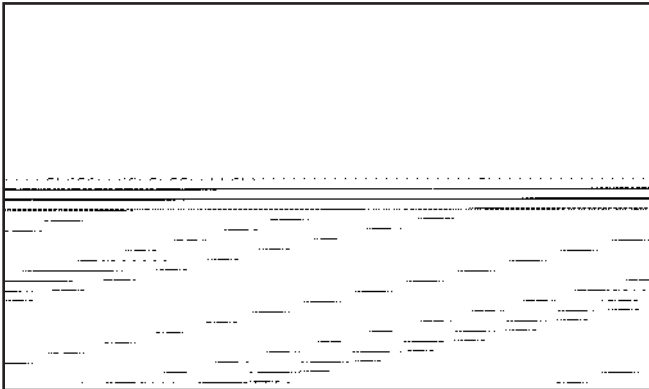
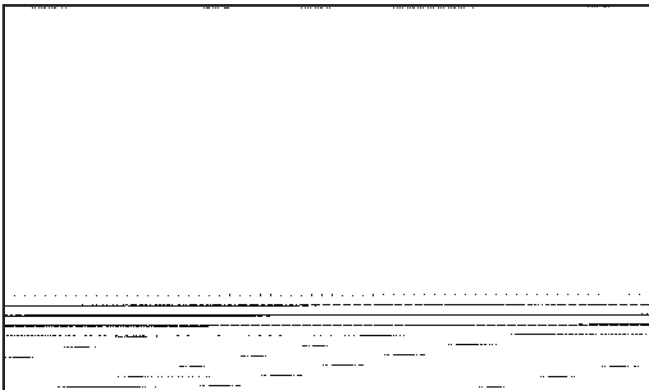
Figure 10A**Figure 10B****SETTING THE AIR ADJUSTMENT PLATE** (See figure 11)

1. The hydraulic AIR SHUTTER (A) is operated by the HYDRAULIC JACK (F), assuring complete opening of the combustion air intake. Regulation of the combustion air flow is made by adjustment of the manual AIR ADJUSTMENT PLATE (D) after loosening the FIXING SCREWS (C and E). The initial setting of the air adjustment plate should be made according to page 16.
2. The proper number on the manual AIR ADJUSTMENT PLATE (D) should line up with the SETTING INDICATOR (B) on the fan housing cover. Once set, the air adjustment plate should be secured in place by tightening SCREWS C and E. Manually open and release the hydraulic air shutter to ensure it has free movement.
3. The final position of the air adjustment plate will vary on each installation. Use instruments to establish the proper settings for maximum CO₂ and a smoke reading of zero.

NOTE: Variations in flue gas, smoke, CO₂ and temperature readings may be experienced when the burner cover is put in place. Therefore, the burner cover **must** be in place when making the final combustion instrument readings, to ensure proper test results.

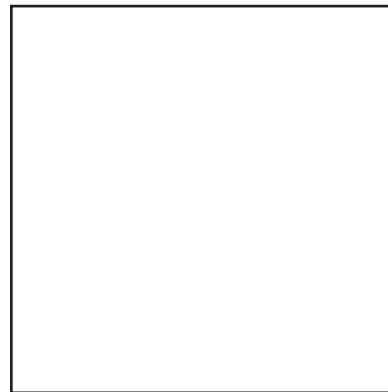
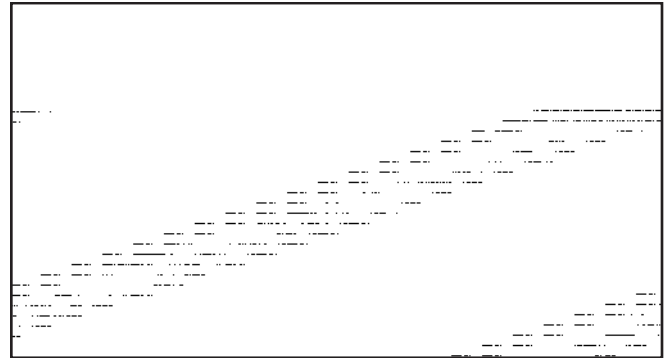
Figure 11**Figure 12****FOR PROPER INSERTION INTO COMBUSTION CHAMBER**

BURNER DATA — CARLIN BURNERS FOR PACKAGED BOILERS ONLY
 (For knocked-down & boiler burner units see publication no. L-42KB)

BOILER MODEL	BURNER MODEL *	FIRING RATE NO.2 OIL (GPH)	NOZZLES			OIL PUMP PRESSURE SETTING (PSIG)	"A" APPROX. HEAD SETTING NO. †	APPROX. AIR BAND OPENING % †						
			SIZE (GPH)	ANGLE & TYPE	MFR.									
LD-20	71357 99-FRD	.75	.75	70° A	DELAVAN	100	1.0—2.0	45—50						
LD-30H	71357 99-FRD	1.00	1.00	60° A	DELAVAN	100	2.0—3.0	70—80						
LD-30	71357 99-FRD	1.10	1.10	60° A	DELAVAN	100	2.0—3.0	80—90						
	71357 99-FRD	1.25	1.25	60° A	DELAVAN	100	2.0—3.0	90						
LD-40H	71373 99-FRD	1.50	1.50	45° ES	HAGO	100	3.0	50						
				70° B	DELAVAN									
LD-40	71373 99-FRD	1.60	1.50	70° SS	HAGO	113	4.0	60						
				70° W	DELAVAN									
				71373 99-FRD	1.80				1.75	70° SS	HAGO	105	5.0	90
LD-50H	71399 99-FRD	2.00	2.00	45° P	HAGO	100	3.0	40						
				60° B	DELAVAN									
LD-50	71399 99-FRD	2.10	2.00	70° W	DELAVAN	110	3.0	50						
				70° SS	HAGO									
				71399 99-FRD	2.35				2.25	70° W	DELAVAN	109	5.0	60
LD-60	71316 102-CRD-3	2.60	2.50	70° P	HAGO	108	5.0	50						
				70° W	DELAVAN									
				71316	2.85				2.75	70° P	HAGO	107	6.0	80
				102-CRD-3	2.60				2.50	45° SS	HAGO	107	5.0	50
LD-60 BAR N.Y.C. ONLY	87189 102-CRD-3	2.60	2.50	45° SS	HAGO	107	5.0	50						
LD-70	71332 102-CRD	3.10	2.75	60° SS	HAGO	125	8.0	90						
				60° W	DELAVAN									
				71332	3.35				3.00	60° SS	HAGO	125	10.0	90
				102-CRD	3.10				3.00	60° W	DELAVAN	107	8.0	90
LD-70 BAR N.Y.C. ONLY	78790 102-CRD	3.10	3.00	60° B	DELAVAN	107	8.0	90						
LD-70C	71332 102-CRD	3.00	2.75	60° SS	HAGO	119	7.0—8.0	80—90						
				60° W	DELAVAN									

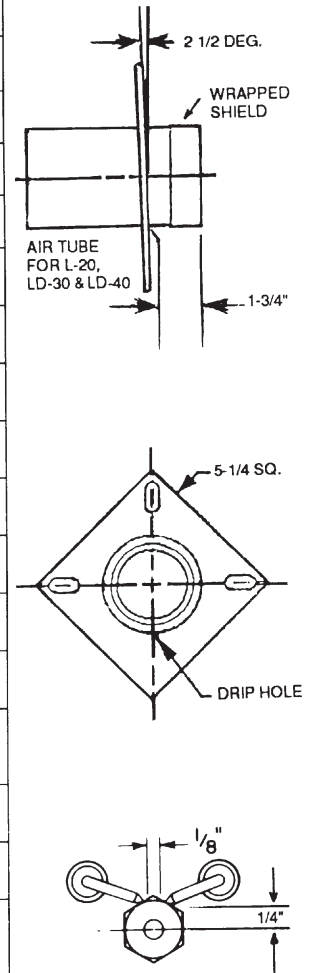

† Head and air band settings are approximate ONLY.
 See START-UP on page 8 and burner figure below.
 * All burner models shown are single stage.

NOTE:

1. The air shutters on the burners for models LD-20, LD-30 and LD-40 are blank (closed).
2. The air shutters on the burners for models LD-50, LD-60 and LD-70 are full open.
3. Single slotted air band for LD-20 and LD-30.
4. Double slotted air band LD-40, LD-50 LD-60 and LD-70.

See table for approximate settings.

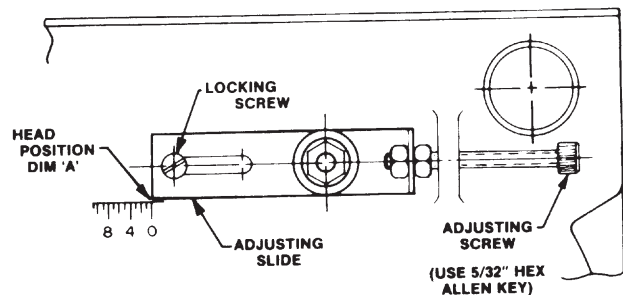
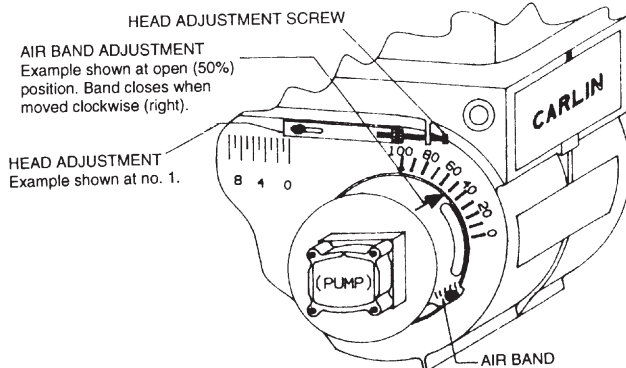
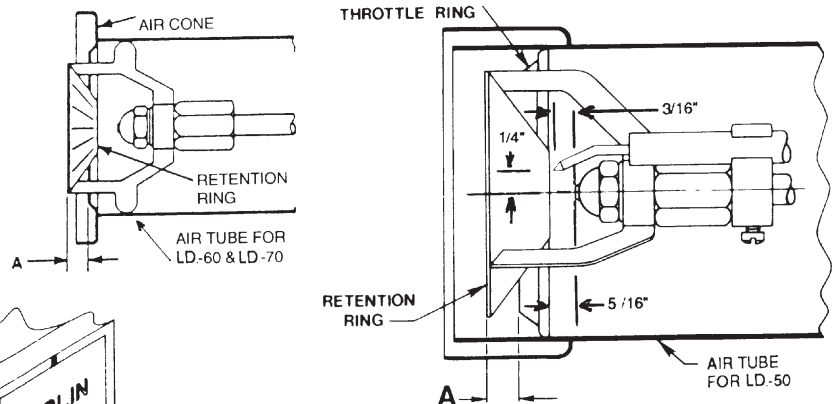

BURNER DATA — WAYNE BURNERS FOR PACKAGED BOILERS ONLY
 (For knocked-down & boiler burner units see publication no. L-42KB)

BOILER MODEL	BURNER MODEL *	FIRING RATE NO.2 OIL (GPH)	NOZZLES			OIL PUMP PRESSURE SETTING (PSIG)	"A" APPROX. HEA SETTING†	APPROX. AIR BAND SETTING †
			SIZE (GPH)	ANGLE & TYPE	MFR.			
LD-50	EH	2.15	2.00	80° B	DELAVAN	115 (BAR)†	3/8" Back	1/2"
		2.35	2.25	80° B	DELAVAN	109	1/8" Back	3/4"
				80° P	HAGO			
LD-60	EH	2.60	2.50	80° W	DELAVAN	108 (BAR)†	1/8" Forward	3/4"
				80° SS	HAGO			
		2.85	2.75	80° P	HAGO	107	1/8" Forward	1-1/8"
				80° W	DELAVAN			
LD-70	EH	3.00	3.00	70° W	DELAVAN	100 (BAR)†	1/4" Forward	1-1/2"
		3.10	3.00	70° SS	HAGO	107	1/4" Forward	1-1/2"
				70° W	DELAVAN	107		
				70°W	DELAVAN	125		
		3.35	3.00	70°SS	HAGO	113	1/4" Forward	1-7/8"

* Choke 3" (Wayne part no. 12329); Static Disc 2-1/2", 6" air tube; 1-3/4" insertion for the welded flange.

† Burner specifications marked "BAR" are for Liberty II boilers approved for use in N.Y.C. by Bureau of Air Resources.

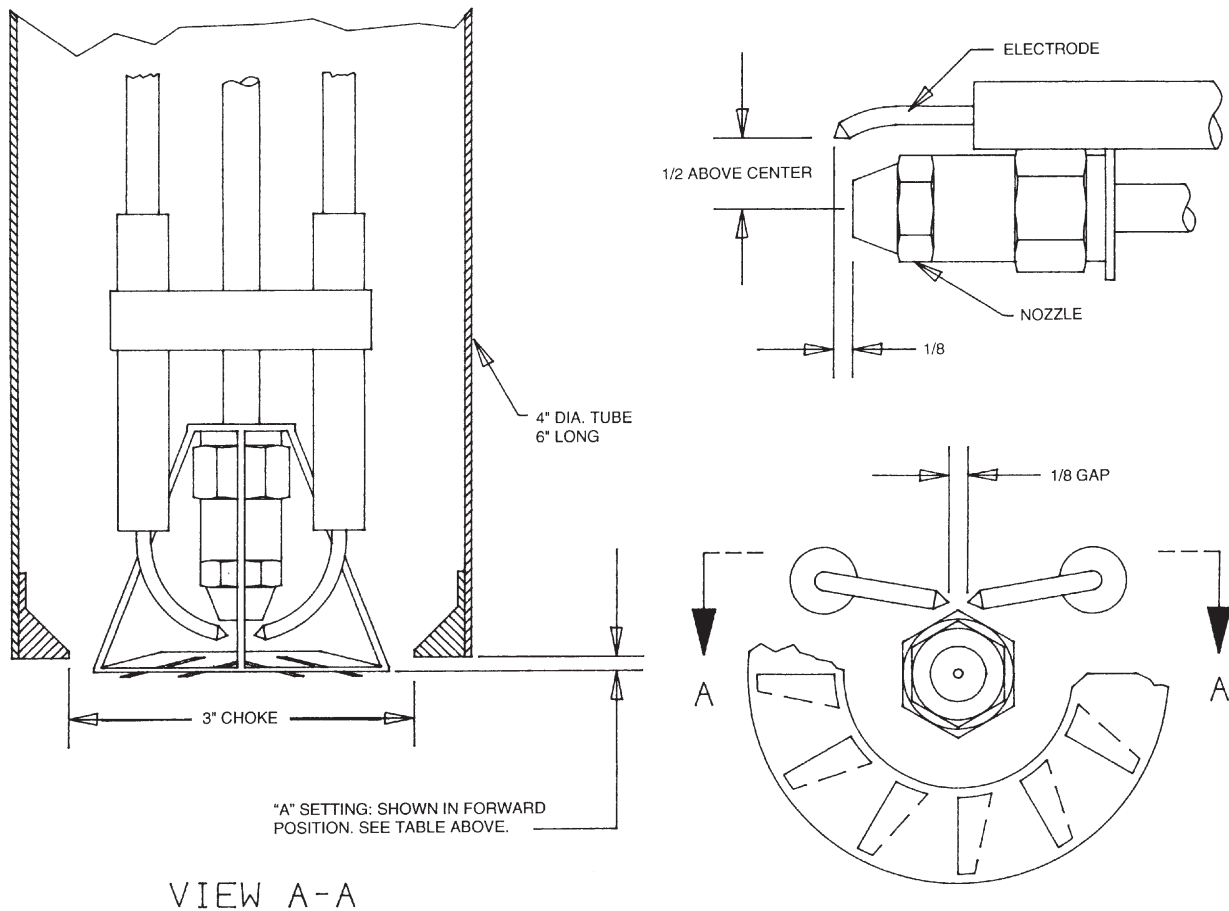

CARE AND MAINTENANCE

CAUTION: DO NOT ATTEMPT TO START THE BURNER WHEN EXCESS OIL HAS ACCUMULATED, WHEN THE UNIT IS FULL OF VAPOR, OR WHEN THE COMBUSTION CHAMBER IS VERY HOT.

CAUTION: DO NOT TAMPER WITH THE UNIT OR CONTROLS—CALL YOUR SERVICE PERSONNEL.

I. EXTENDED SHUTDOWN, CLEANING OR REMOVAL OF BOILER FROM SERVICE.

DANGER: Use CAUTION when handling chemicals and draining hot water from a boiler. Scalding water and/or chemicals can cause permanent injury to the skin, eyes and respiratory system.

- A. Shut down burner by disconnecting all electrical power to the burner by turning OFF the BURNER EMERGENCY SWITCH of this boiler. After shutting down burner, while the boiler is still hot (180°F to 200°F), drain water from the bottom of the boiler until it runs clear.
- B. Provide corrosion protection conditioning to the boiler water in the heating system. There are a number of commercial heating system preparations available from your distributor. Follow the preparation manufacturer's instructions.
 1. For steam boilers, maintain a *sodium chromate* solution strength of 16 oz. per 50 gallons of water; and refill to the top of the gauge glass.
 2. For water boilers, maintain a *sodium chromate* solution strength of 6 oz. per 50 gallons of water, and refill to normal fill-pressure with system vented.
 3. Raise water temperature to at least 180°F. for one hour to release dissolved gases.
 4. Shut down burner by disconnecting the main switch.
- C. To clean the fireside boiler surfaces, first shut down burner by disconnecting all electrical power to the burner by turning OFF the OIL BURNER EMERGENCY SWITCH of this boiler in order to perform the following work in (1) through (10) below.
 1. Remove the flue pipe from the boiler flue collar and clean thoroughly.
 2. Inspect the entire vent connector back to the chimney and clean if necessary.
 3. Inspect the chimney for soot, debris and other unsafe conditions of the chimney and take the necessary action.
 4. Remove the flue collector by first removing the top jacket panel. The flue collector is held in place by two hex 1/4-20 screws. Remove the screws and carefully remove the flue collector. Try not to disturb the flat fiberglass rope under the flue collector.
 5. When necessary to clean the combustion chamber you must first CLOSE the suction valve (and return valve if two pipe). Then disconnect the oil lines from the burner. The flexible electric conduit connected from the junction box on the boiler to the burner via a plastic connector must be disconnected from the burner by grasping the plastic half of the connector closest to the flexible conduit and gently pulling it in the direction of the conduit until it is disconnected. Remove the single 3/8-16 hex head screw on the LEFT side of the swinging door. You will need a 9/16" drive socket. Open the door to completely expose the combustion chamber for thorough cleaning and for inspection of target wall, blanket (provided in certain models; see rating plate), main cast iron burner door insulation and burner door fiberglass sealing rope. If combustion chamber parts above are badly deteriorated then replace with original factory parts available at your distributor.
 6. Use the flue brush to clean the pinned flueways between the sections.† A wire brush may be used to remove any carbon accumulation that may have developed in the combustion chamber. Vacuum the loose soot and debris from the boiler.
 7. Inspect the burner combustion head. Clean if necessary and make sure all the adjustments are correct. (See burner data pages for the burner installed.) Replace oil nozzle with new one and readjust electrodes. To insure proper burner operation ONLY THE NOZZLES SPECIFIED IN THIS MANUAL OR ON THE BURNER LABEL SHOULD BE USED FOR REPLACEMENT.
 8. Close main cast iron burner door (door on which burner is mounted). Make sure that the entire seal (fiberglass rope) is making good contact with the boiler casting when replacing 3/8-16 x 1" long hex head bolt and tightening.

9. Check the flue collector seal. This is the flat rope seal on top of the heat exchanger. The rope must be in place adjacent to the long bosses on front and rear sections and adjacent to the short bosses on the intermediate sections. The rope should be directly under the flue collector flanges when the flue collector is replaced. Use the two 1/4-20 x 3/4" washer hex head screws to fasten the flue collector. In order to assure a proper seal be sure that the flue collector is compressing the flat rope and not hanging up on the section bosses. Tighten the two screws.

D. If boiler room is damp, provide ventilation.

CAUTION: ALWAYS KEEP THE OIL SUPPLY VALVE SHUT OFF IF THE BURNER IS SHUT DOWN FOR AN EXTENDED PERIOD OF TIME.

II. PROVIDING PROTECTION FOR FREEZING

Anti-freeze is sometimes used in hydronic heating systems to protect against freeze-up in the event of power failure, or safety control shutdown when the building is unoccupied. It should be recognized that unless the building is kept above freezing temperature by some means, the plumbing system is not protected.

PROPYLENE GLYCOL is used in the quick-freeze food industry; it is practically non-toxic. Its use may be permitted when tankless heaters are used. When anti-freeze must be used, inhibited propylene glycol is recommended. Useful information on the characteristics, mixing proportions, etc. of glycol in heating systems is given in Technical Topics No. 2A, available from the Hydronics Institute, 35 Russo Place, Berkeley Heights, N.J. 07922. Consult glycol manufacturers for sources of propylene glycol. DO NOT use ethylene glycol because it is toxic.

III. OIL BURNER

All service to the oil burner, oil filter, oil strainers, etc., should be performed by a professionally trained service person. Inspect and clean annually and following any period of improper operation. Recheck and adjust settings as specified for burner model and nozzle size. Set burner air and draft regulator, using test instruments to obtain recommended CO₂ and draft without smoke. Refer to page 8.

IV. GENERAL MAINTENANCE

These operations are recommended to be performed at regular intervals:

- A. BOILER HEATING SURFACES: clean off all coatings found. Reseal covers.
- B. BOILER CONTROLS: check contacts, settings, correct functioning.
- C. PIPING: check piping and accessories for leaks.
- D. CHIMNEY or STUB VENT and BREECHING: check for obstructions and leaks.
- E. COMBUSTION AIR TO BURNER: check for continued POSITIVE supply of air as required. Air needs are greatest in coldest weather. Refer to AIR SUPPLY, page 3.
- F. WATER SYSTEM: check
 1. System to be full of water and pressure to remain stable (between 12 psi and 25 psi).
 2. Air-control system: noise and air binding in radiation should not occur.
 3. Water lines: slightest leaks should be corrected.
 4. Low water cut-off, for operation (see instructions furnished with unit). See page 9.
- G. STEAM SYSTEM: check
 1. Low water cut-off, for operation (see instructions furnished with unit). See page 9.
 2. Check pressure cut-off for operation. See page 10.
 3. Any unusual water conditions. Obtain water analysis and treat water.
- H. BOILER ROOM AIR SUPPLY: air vents should be open and free of obstruction. See page 3.

† A flue brush (2-1/4" dia.) is supplied with boiler. Replacements are available from dealer or hardware stores.



A series of 25 horizontal lines spaced evenly down the page, providing a template for handwriting practice.



SLANT/FIN CORPORATION, Greenvale, N.Y. 11548 • Phone: (516) 484-2600

FAX: (516) 484-5921 • *Canada: Slant/Fin LTD/LTEE, Mississauga, Ontario*

www.slantfin.com