

ACCESSORY KIT INSTRUCTIONS FOR SURFACE WALL MOUNTING

The KICKER

Multi-purpose fan convection heater

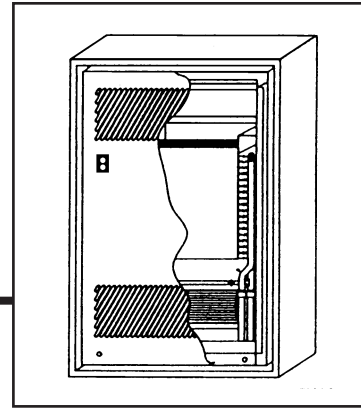

Instructions for mounting The Kicker model TK-70 or TK-90 in a surface wall mount application.

1. Change switch location. See Fig. 1.
2. Change the location of the air vent by interchanging the 1/4" NPT plug and the air vent, both of which are assembled to the coil header. See Fig. 2.
3. Attach both side panels (flange facing outward) to the base of The Kicker with (4) #8 x 1/4" screws provided. See Fig. 3.
4. Attach bottom rail, plenum and partition to each side with (8) #8 x 1/4" sheet metal screws provided. See Fig. 3.
5. Assemble cabinet sides, top and cabinet bottom. Attach to plenum with (10) #8 x 1/4" sheet metal screws. See Fig. 4, Fig. 5 and Fig. 6.
6. Follow instructions packed with The Kicker for water and electrical connections, and for operation.
7. Fasten front panel in place with (2) 8 x 1/2" sheet metal screws provided. See Fig. 7.

PARTS INCLUDED		
Part No.	Qty.	Description
250020000	1	Front panel
250021000	1	Left side
250022000	1	Right side
250023000	1	Plenum
250025000	1	Bottom rail
250029000	1	Partition
250060000	1	Cabinet top
250061000	1	Cabinet bottom
250062000	2	Cabinet sides
970107000	2	#8 x 1/2" sheet metal screws
980042000	22	#8 x 1/4" sheet metal screws

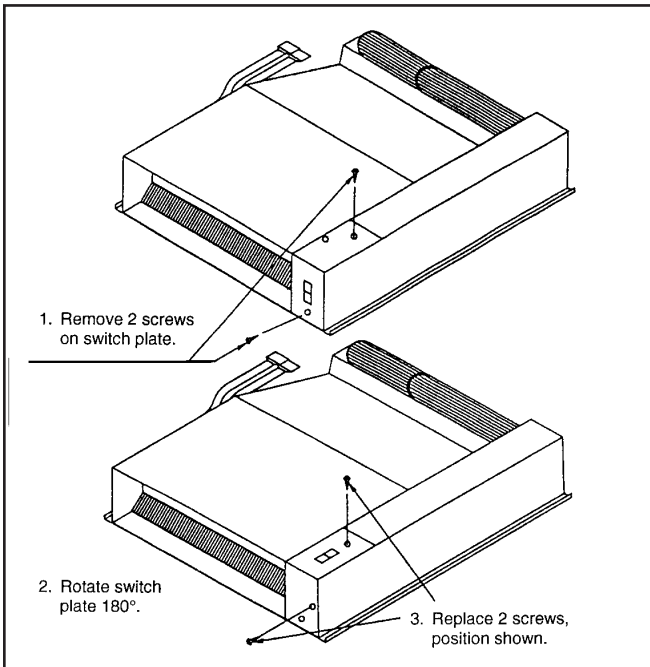

Figure 1. Changing the switch location

The control switch is factory installed for kickspace (horizontal) application. For wall mounting The Kicker in a vertical position, remove the switch assembly and reinstall as shown.

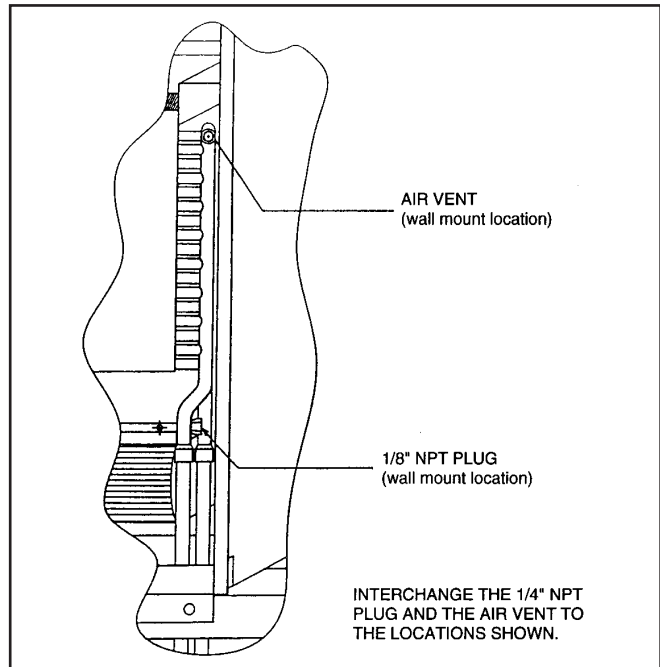

Figure 2. Air vent installation

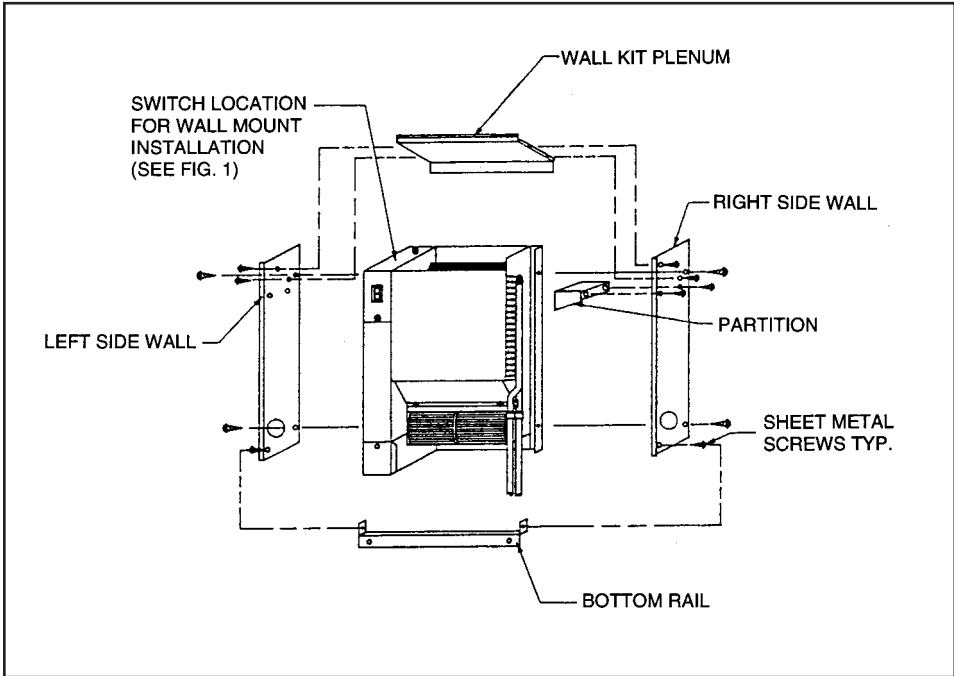

Figure 3. Frame assembly

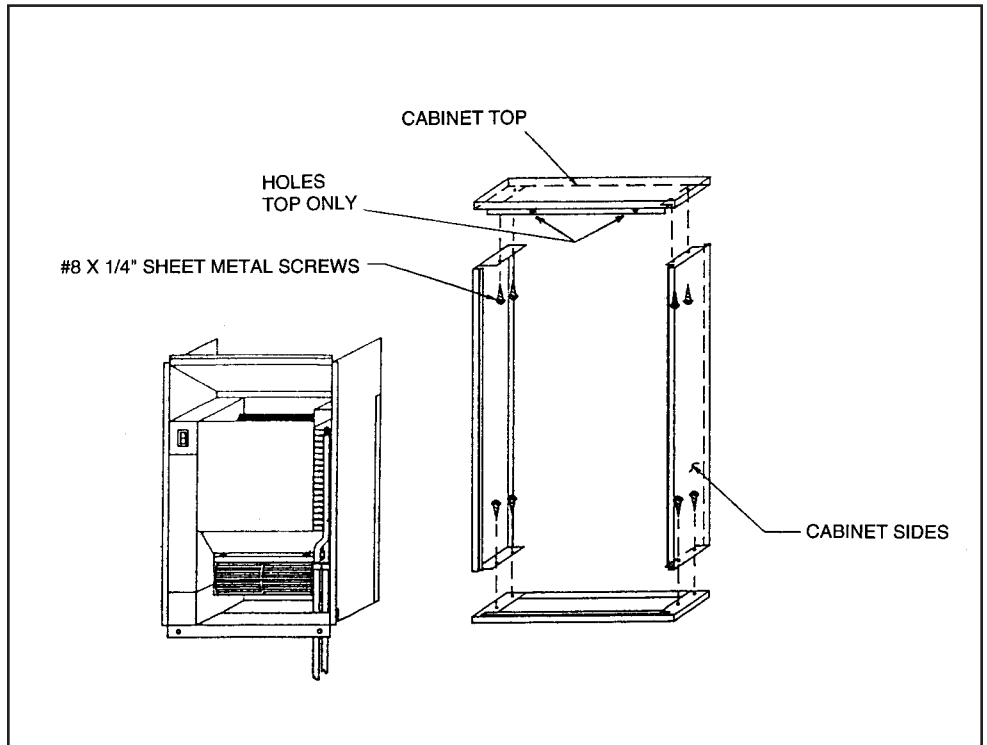

Figure 4. Cabinet assembly

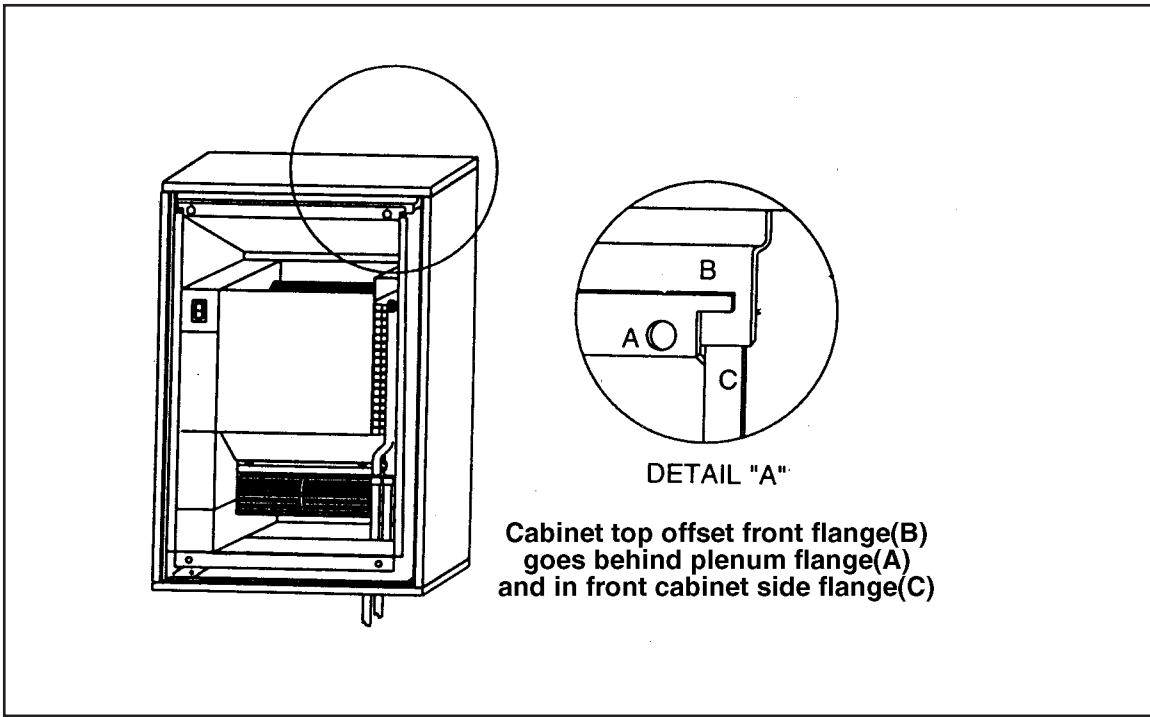

Figure 5.

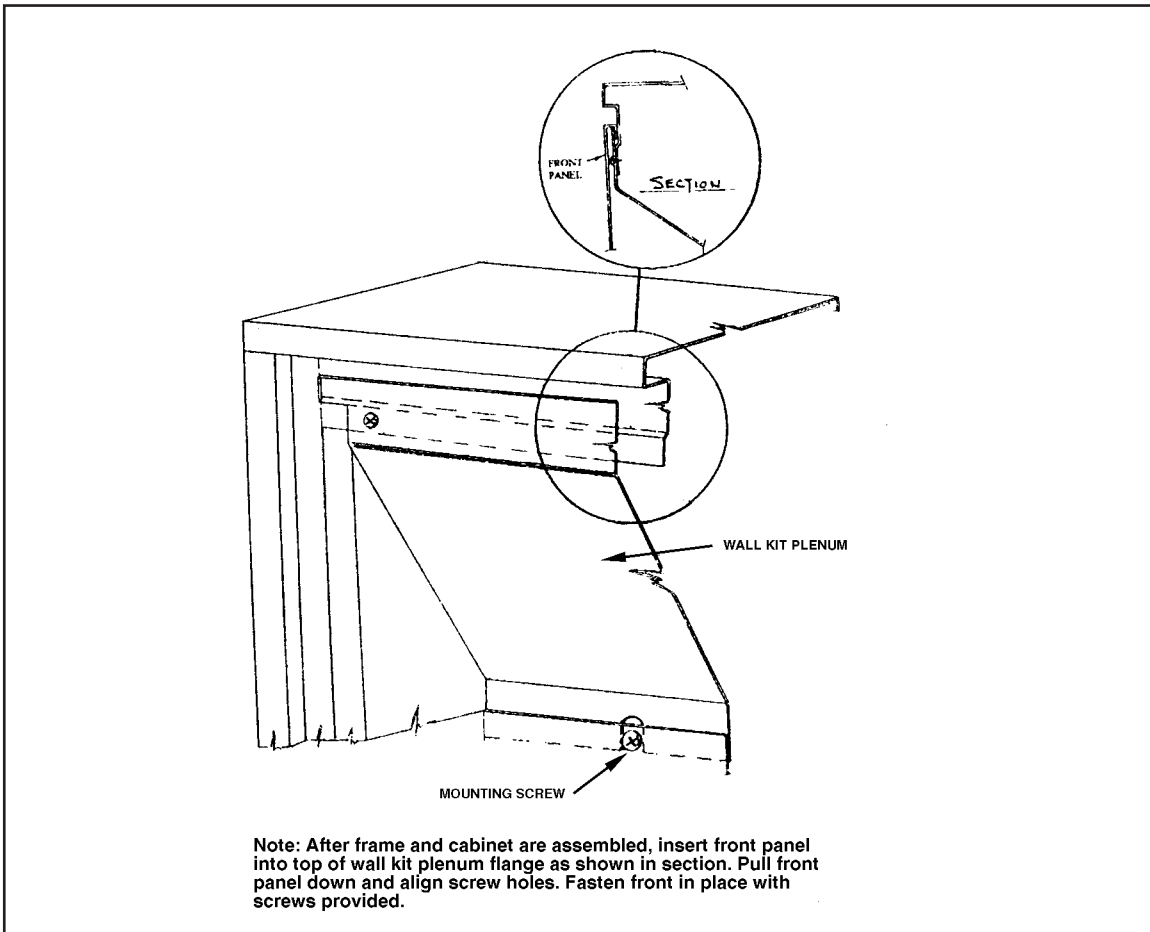

Figure 6.

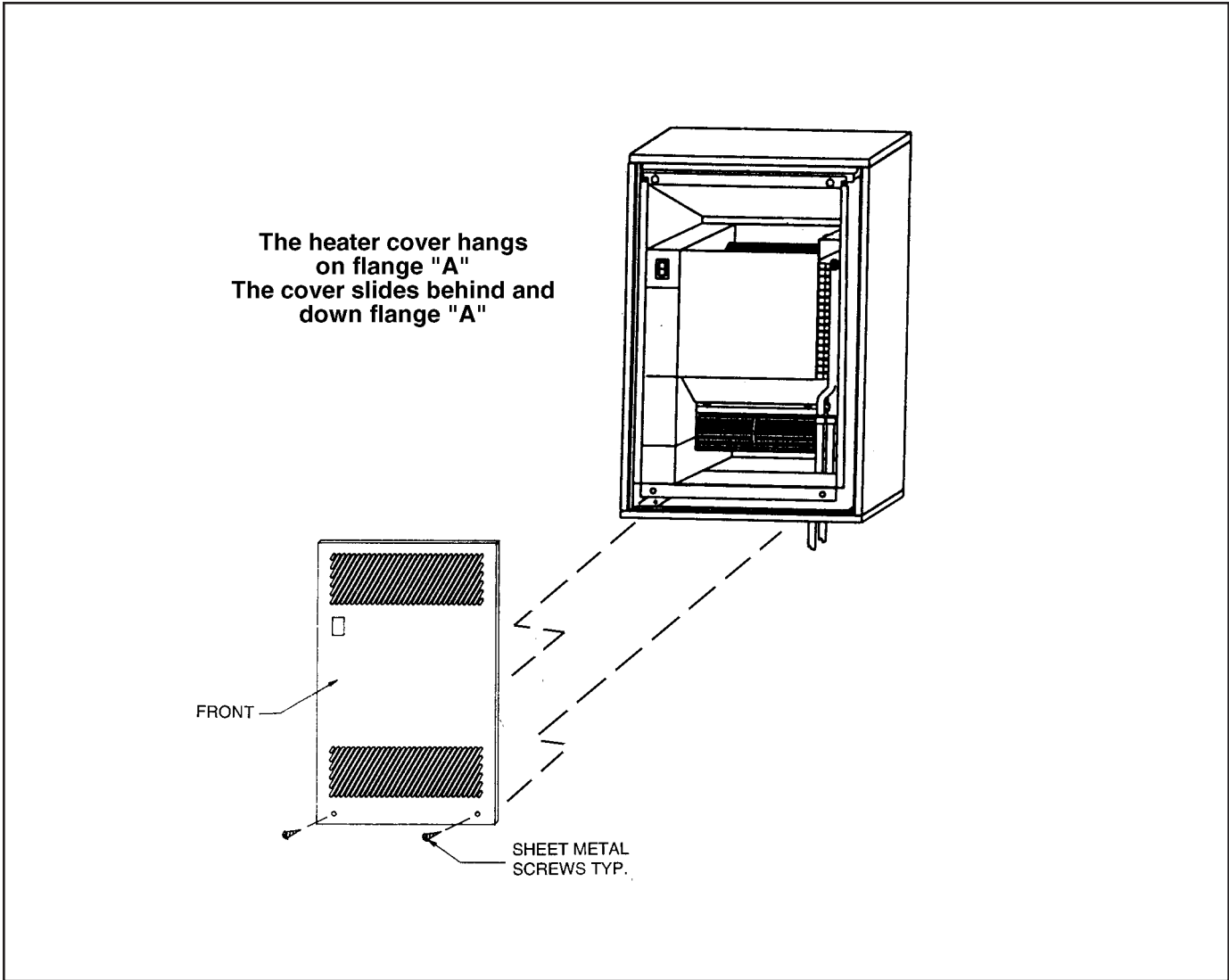

Figure 7.