

CARAVAN

SC2000 CONTROLLER INSTALLATION AND OPERATION MANUAL

*For Gas-Fired, Oil-Fired
and Dual Fuel Hot Water
Heating Plants*

CONTENTS

- Controller Installation1-9
 - a) Components Location2-4
 - b) Wiring and Connections5-9
- Program Pad and Functions10
- Programming11-13
 - a) Space Heat11-12
 - b) Setpoint12-13
- Viewing Sensor and Calibration13-14
- Fine Tuning SC200015
- Setback Programming16-18
- Troubleshooting19
- SC2000 Controller Specs20

SC2000 Applications

- Space Heat Systems With Outdoor Reset
- Space Heating With Outdoor Reset and Space Temperature Control
- Constant Temperature Setpoint Control
- Any Of These In Combination With Domestic Hot Water Heating

The SC2000 is a factory pre-wired microprocessor control which will sequence up to eight heating stages based on room temperature, outdoor air temperature and supply water temperature. Designed to handle a Caravan gas-fired, oil-fired or dual fuel-fired hot water heating plant for space heating or "Setpoint" operation, or either in combination with domestic water heating.

SPACE HEATING OPERATION: When the outdoor air temperature drops below a preset value, the heating system is energized. The SC2000 Controller determines the number of stages required to meet the space heating needs and fires them. During operation, the Controller scans system temperatures, adding or deleting stages as necessary to satisfy

Controller Packing List

SC2000-4 Stage or -8 Stage Control Panel, Installation and and Operation Manual, Precision Resistor, (2) Temperature Sensors, Supply Water Temperature Sensor Mounting Kit and Outdoor Temperature Sensor Mounting Assembly.

Systems using Optional Space Temperature Control Feature: Additional Temperature Sensor (Total of Three) and Space Sensor Mounting Kit.

heating load. "Lead/Lag" sequencing of the stages provides for evenly distributed run-times of the modules.

SETPOINT OPERATION: The SC2000 adds and deletes stages to minimize the difference between the desired Setpoint temperature and the actual measured Supply Water Temperature. The Outside and Space Temperature Sensors are not required.

DOMESTIC WATER HEATING: When configured for "DHW" (Service Water Heating), the control holds stage #8 out of the Lead/Lag firing sequencing until all other active stages are energized. Only when the heating load reaches a maximum will the Stage #8 relay energize. At the same time, a

This manual must be left with owner, hung on or adjacent to control panel. Owner should retain manual for future reference.

motorized valve opens allowing the DHW modules to contribute to space heating. If water temperature in the DHW modules falls below a pre-set value, the motorized valve will close, retaining module capacity for domestic water heating.

CONTROL PANEL COVER: An LED display shows the Space Temperature Sensor reading, when that Sensor is used. Otherwise, the LED displays the Supply Water Temperature Sensor reading. Individual lights indicate the energized stages. Another light indicates Setback Mode operation.

OPTIONAL SPACE TEMPERATURE SENSOR: In a heating system that has no zone controls, the space temperature sensor can provide temperature control of the heated space. The heating system's speed of response to changes in the heating load is greatly improved compared to controlling by supply water and outside temperatures alone.

SYSTEMS WITH ZONED TEMPERATURE CONTROLS: The SC2000 is entirely compatible with Zone Temperature Controls. Temperatures supplied to the zones will be adjusted by the SC2000 control according to the temperature outside. Zone Controls will react by remaining "on" for longer times, producing more even, less wasteful heating.

OPTIONAL SPACE TEMPERATURE SENSOR IN ZONED HEATING SYSTEMS: If Zone Temperature controls are used, arrange one zone to be controlled directly by the Space Temperature Sensor. The entire system's speed of response to changes in the heating load will be substantially improved. In particular, the system response going into and returning from Setback is faster and more accurate.

CONTROLLER INSTALLATION

INSTALLING SENSORS

- A basic space-heating system requires at least an outdoor temperature sensor and supply water temperature sensor.
- When the Space Temperature control feature is used, a third Sensor is required, in addition to the outdoor and supply water sensors.
- Sensors must be installed following the sensor manufacturer's instructions. Mount outdoor sensor on a north (shaded) wall; mount optional space sensor in an unconfined area (i.e. not an individual office) where it can be most effective for entire space to be heated.
- Use 18-gauge wire for sensors.
- DO NOT run sensor wiring in same conduit with power wiring. **Use shielded cable** (2-wire plus shield) for sensor wiring.

MOUNTING CONTROLLER

- Dimensions: 14-1/4" High; 12-1/4" Wide; 3-1/2" Deep.
- Locate on convenient wall in boiler room.
- Use mounting holes provided.

WIRING TO CONTROLLER

Electrical wiring must conform to local, state and national codes, ordinances and laws; National Electrical Code ANSI-NFPA 70-latest edition; In Canada: the Standard C.S.A. C22.1 Canadian Electrical Code, Part 1 and 2; and additional requirements in this manual.

- Keep all wiring runs as short as possible.
- Use knockouts provided on each side of control box.
- For wire terminals, after stripping wire, push it into the numbered slot and tighten terminal screw.
- Power, sensor and control wiring connections shown on pages 4 through 7.

Space Heating or Constant Supply Water Temperature: The Controller will handle up to 15 individual modules (2 each for Stages 1 through 7; 1 for Stage 8).

- For up to 8 modules, connect one module per stage starting with Stage 1, closest module to the chimney.
- For more than 8 modules, see boxed instruction on the opposite page.

Combination Space Heating and DHW: The Controller will handle up to 14 space heating modules and 1 DHW module (or a bank of DHW modules) wired to Stage 8.

- For up to 7 space heating modules, connect one module per stage. DHW module is normally closest to the chimney.
- For more than 7 space heating modules, see boxed instruction on the next page.
- SC2000-4 Controllers are shipped with plug-in relays installed in stages 1 through 4. Move one relay from stage 4 to stage 8.

OPERATION SELECTOR DIP SWITCHES

LEAD-LAG/STD Switch: Rotation of the firing order for lead-lag and standard (STD) system is basically a "first-on/first-off" (FOFO) sequence. Example: Assume a 4-stage system with Stage 1 already firing. As the heating demand increases, Stage 2 would fire next, followed by 3 and 4 (in that order). When heating demand decreases, Stage 1 will turn off first, followed by 2, 3 and 4 (in that order). Position the switch based on the following:

- **LEAD-LAG (FOFO):** When all boilers are off and a call for heat occurs, the stage following the last stage off will be the first stage on; use this selection when it is important to evenly distribute boiler operating time.
- **STD (FOFO):** When all boilers are off and a call for heat occurs, Stage 1 (closest to the chimney) is always first stage on. Slight decrease in even distribution of boiler operating time.

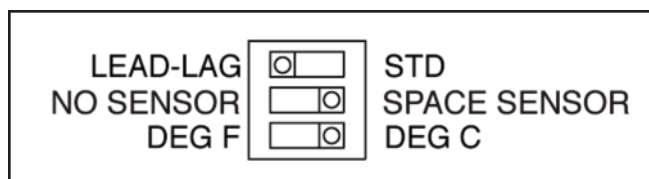

NO SENSOR/SPACE SENSOR SWITCH: Regardless of whether the heating system has zone controls or not:

- Set this switch to SPACE SENSOR if one is used.
- Set the switch to NO SENSOR if one is not used.

DEG F/DEG C Switch: Position the switch based on degrees-Fahrenheit or degrees-Celsius to be shown in display. Either choice can be used for setup; after setup, the switch can be set for either choice and Controller will convert entries.

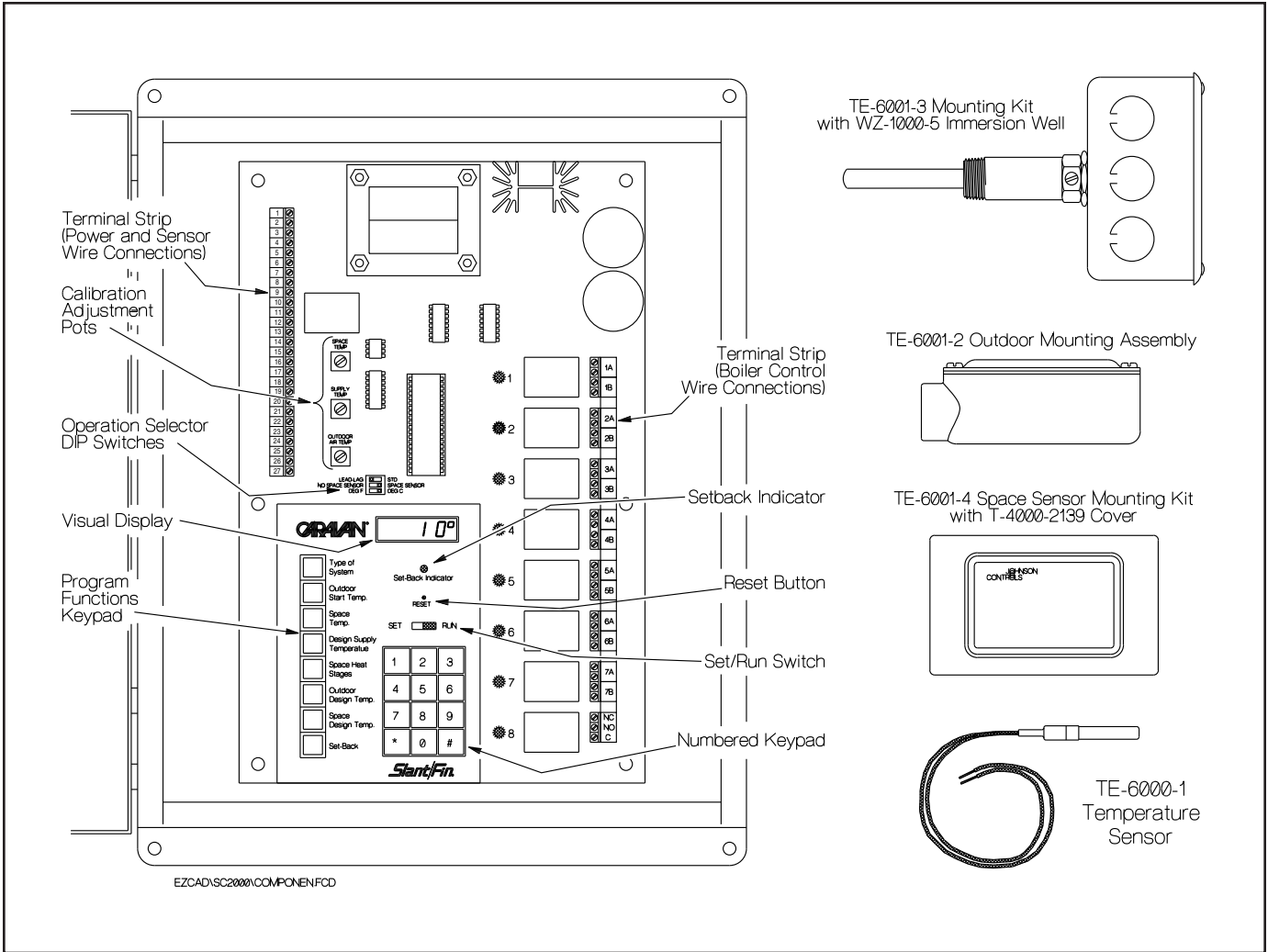

Description of SC2000 Components

WIRING FOR MORE THAN 8 (or 7) SPACE HEATING MODULES

- For space heating or constant supply water temperature: Maximum of 15 modules can be connected directly to panel - 2 each for Stages 1 through 7; 1 for Stage 8.
- For combination space and DHW: Maximum of 14 space heating modules - 2 each for Stages 1 through 7 (Stage 8 for DHW only).

DETERMINE NUMBER OF STAGES TO BE USED

- Assign the modules 2 per stage, starting with Stage 1 and running thru Stage 7.
- Example: 11-module heating plant. Assign 2 modules each for Stages 1 through 5; 1 module for Stage 6.

HOW TO CONNECT MODULES TO CONTROLLER

- For a space heat-only system, start with modules closest to chimney and connect in order leading away from the chimney.
- For a combination space heat/DHW system, start with modules farthest from the chimney, and connect in

- order leading towards the chimney, ending with the DHW modules on stage #8.
- Example: 11-module heating plant with a bank of six modules and a bank of five modules as shown in diagram below.
- Therefore, connections would be as follows:
 Stage 1: Modules 1 and 7 Stage 4: Modules 4 and 10
 Stage 2: Modules 2 and 8 Stage 5: Modules 5 and 11
 Stage 3: Modules 3 and 9 Stage 6: Module 6

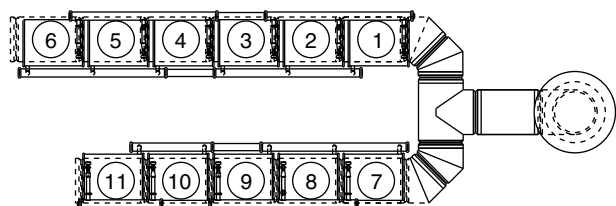

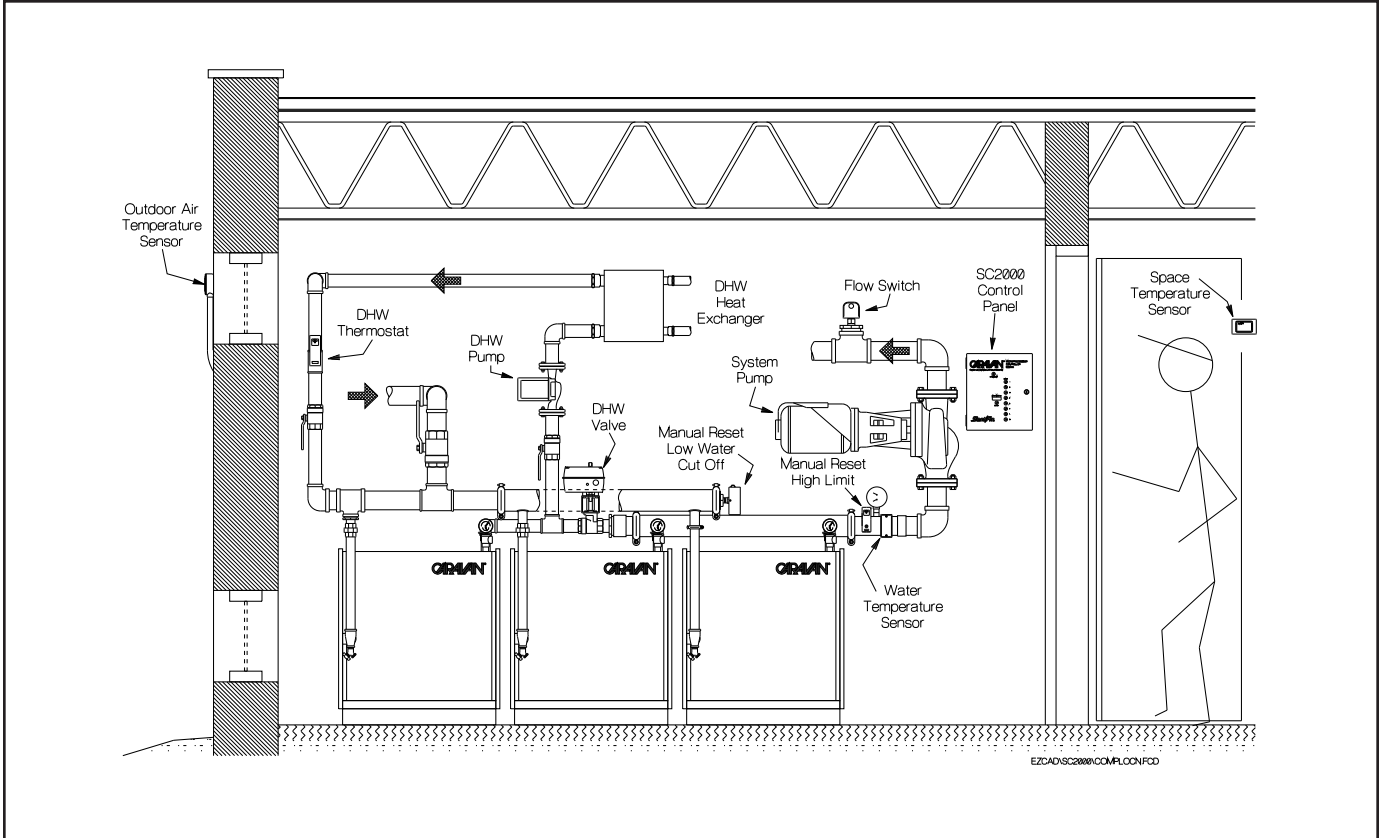

Component Locations

SPACE HEATING WIRING DIAGRAM

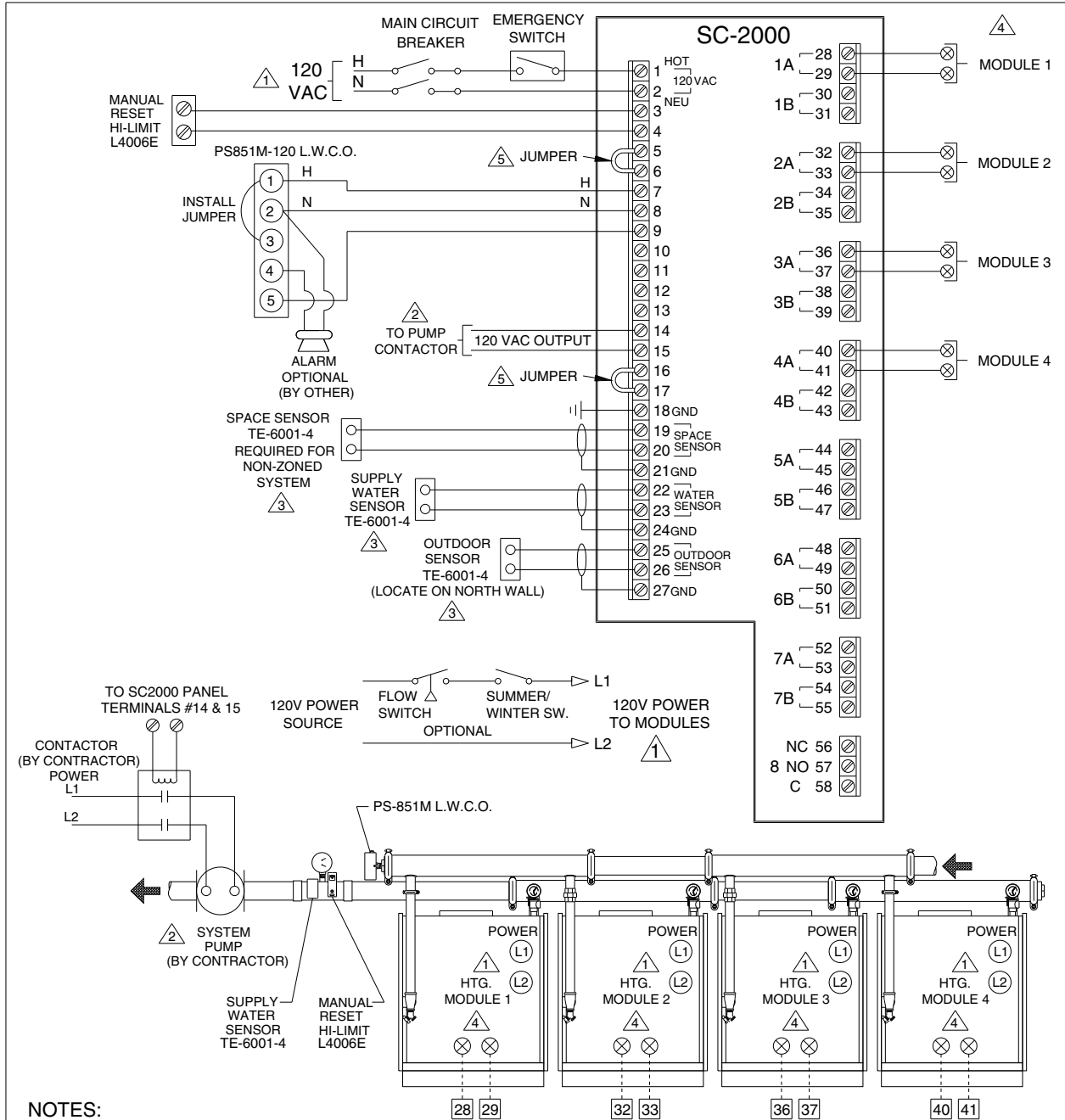

NOTES:

- 1 - PROVIDE DISCONNECT MEANS AND OVERLOAD PROTECTION AS REQUIRED BY LOCAL CODE.
- 2 - SYSTEM PUMP FOR HOT WATER SYSTEM ONLY.
- 3 - SHIELDED CABLE IS RECOMMENDED WHEN WIRING SENSORS.
- 4 - REFER TO FIG. C2 THRU C4 ON PG.9 FOR WIRING AT MODULES.
- 5 - WHEN TERMINALS 5&6 ARE JUMPED THERE IS A 120V OUTPUT ON TERMINALS 10&11. WHEN TERMINALS 5&6 AND 16&17 ARE JUMPED THERE IS A 120V OUTPUT ON TERMINALS 12&13. 2.5 AMPS PER TERMINALS 10&11 AND 12&13 TOTAL 5 AMPS MAX..

DWG FILE #2000-4.FCD

SLANT/FIN CORPORATION 100 FOREST DRIVE, GREENVALE, NEW YORK 11548 / 516-484-2600		
TITLE SCG-2000 CONTROL WIRING HOT WATER HEATING SYSTEM RECOMMENDED CONTROL WIRING		
DATE 8-1-96	DRAWN BY AC	DRAWING NUMBER
DATE	APPROVED	WGW401FA

SPACE HEATING LADDER DIAGRAM

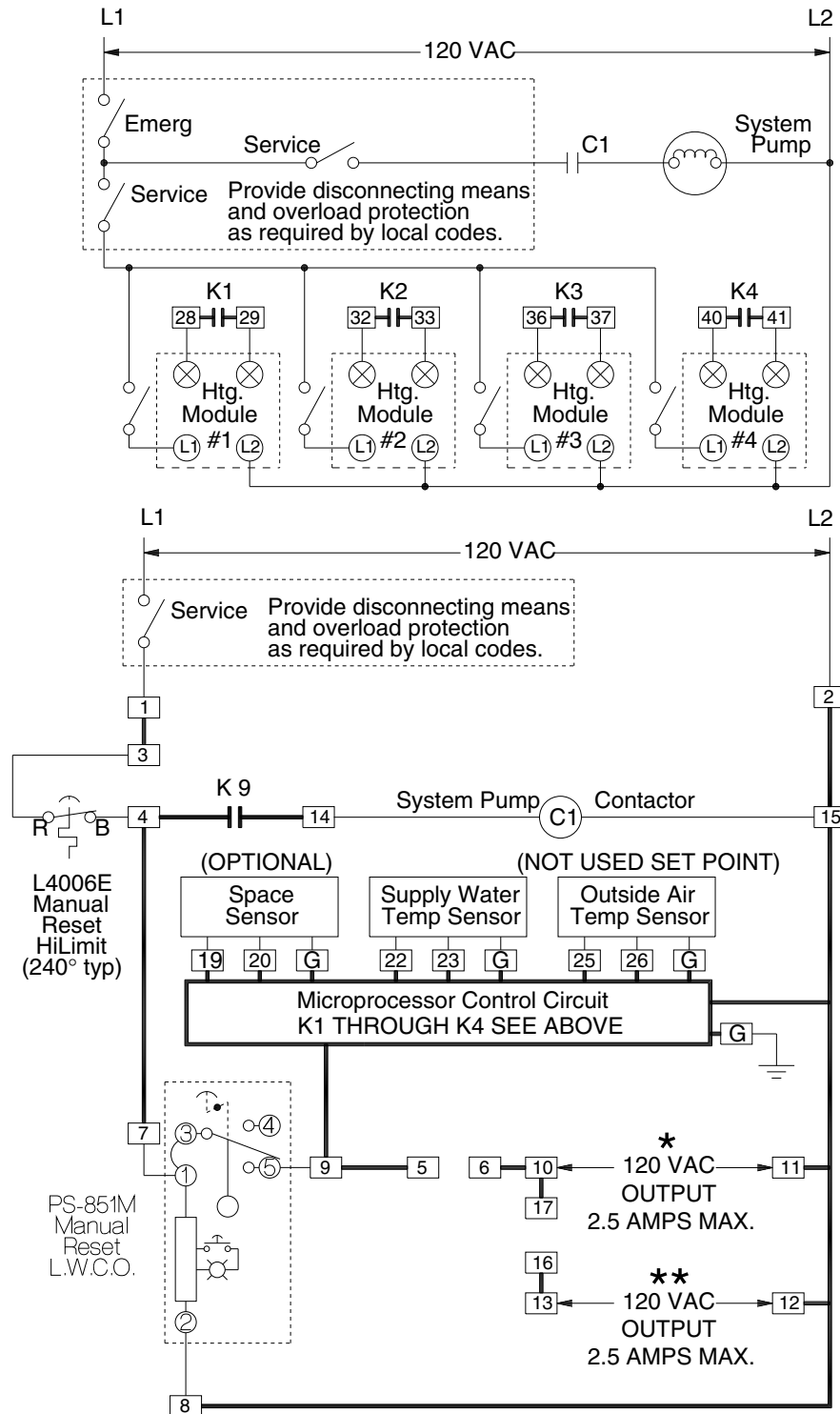

⊗ - SEE FIG. C1 THROUGH C4 FOR CONNECTION AT MODULE.

* - 120V OUTPUT WHEN TERMINALS (5 AND 6) ARE JUMPED.

** - 120V OUTPUT WHEN TERMINALS (5 AND 6) AND (16 AND 17) ARE JUMPED.

SPACE AND DOMESTIC HEATING WIRING DIAGRAM

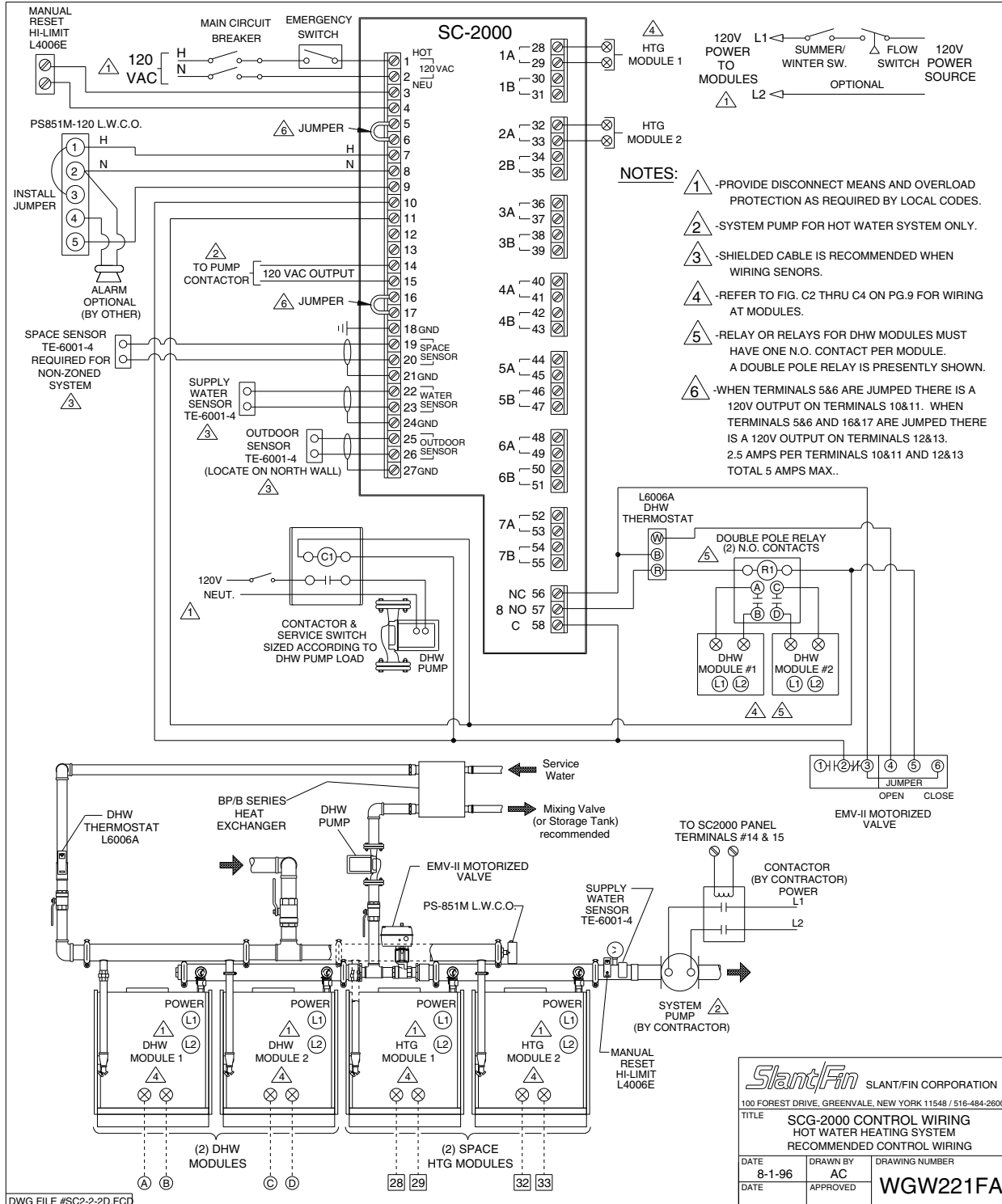

SPACE AND DOMESTIC HEATING LADDER DIAGRAM

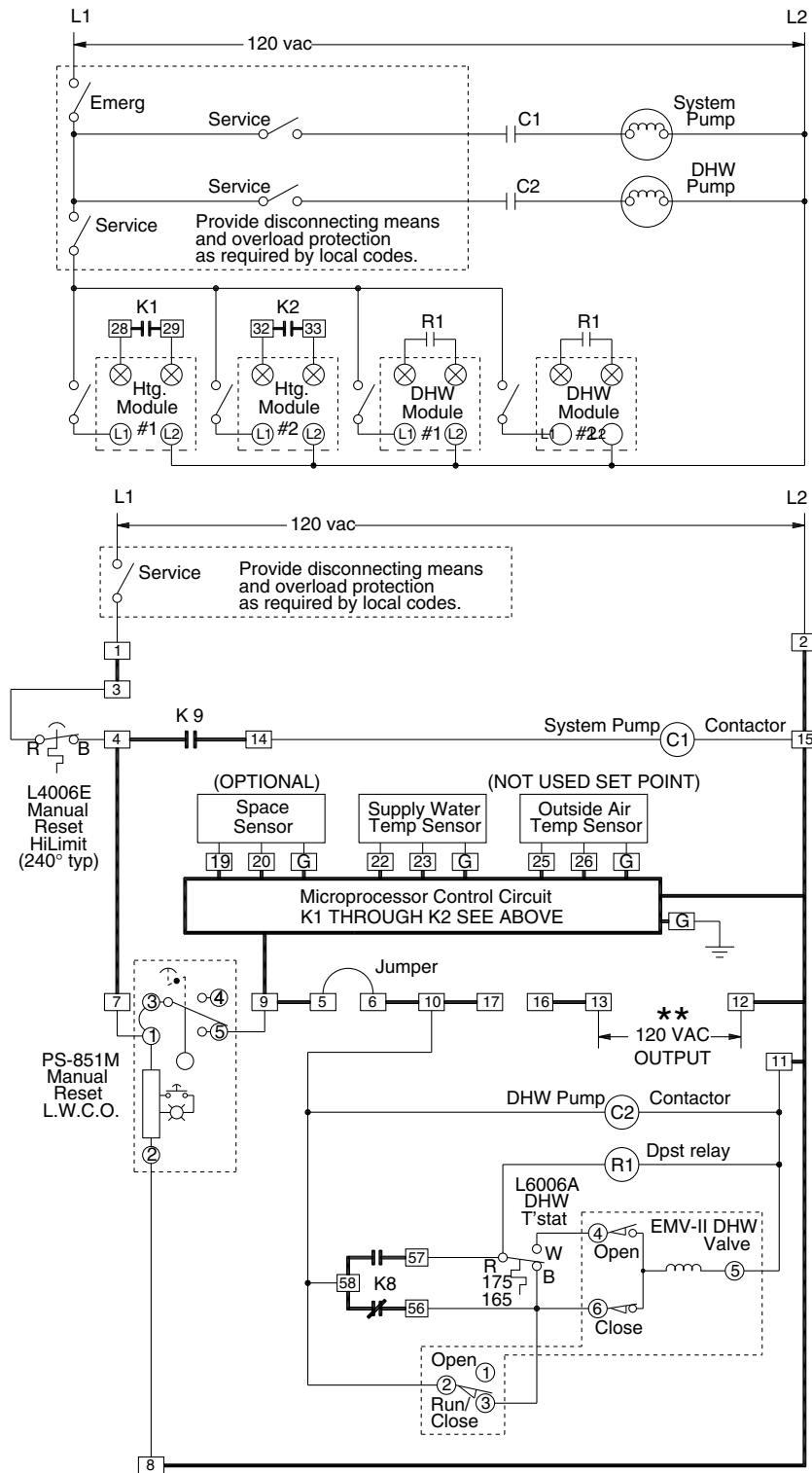

⊗ - SEE FIG. C1 THROUGH C4 FOR CONNECTION AT MODULE.
 ** - 120V OUTPUT WHEN TERMINALS (5 AND 6) AND (16 AND 17) ARE JUMPED.

FIELD WIRING AT MODULES

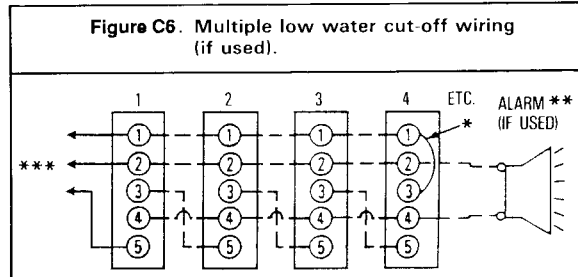
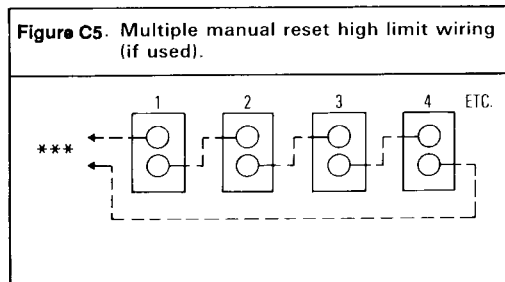
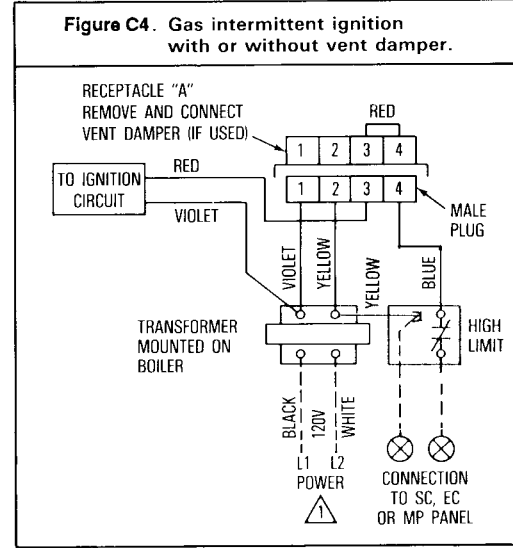
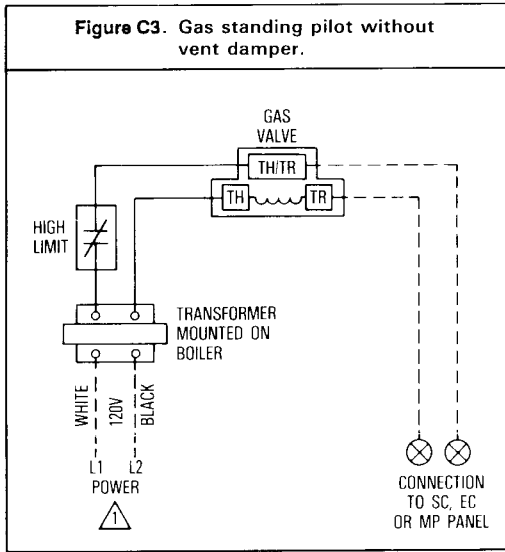
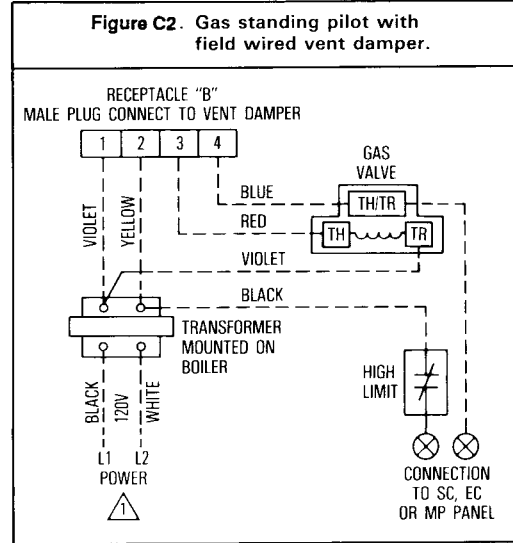
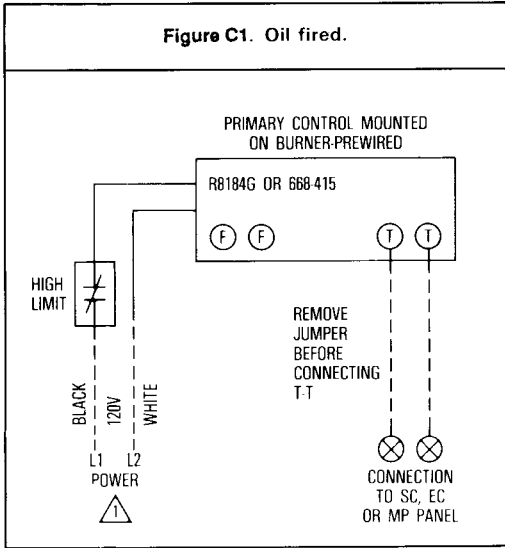

△ PROVIDE DISCONNECT MEANS AND OVERLOAD PROTECTION AS REQUIRED

LEGEND:
—— FACTORY WIRING
--- FIELD WIRING

* Install jumper between Terminals 1 and 3 on last low water cut-off only.
** Optional alarm circuit by contractor.
*** For connection see SC1200 wiring diagrams.

SC2000 PROGRAMMING PAD

CARAVAN®

1 0°

Type of System

Outdoor Start Temp.

Space Temp.

Design Supply Temperature

Space Heat Stages

Outdoor Design Temp.

Space Design Temp.

Set-Back



Set-Back Indicator



RESET

SET



RUN

1	2	3
4	5	6
7	8	9
*	0	#

Slant/Fin®

SPACE HEATING PROGRAMMING

DIP SWITCHES

LEAD-LAG	STD
NO SENSOR	SPACE SENSOR
DEG F	DEG C

Select desired operations from the dip switch selections above and move the dip switch on the panel to that position.

NOTE: See Operation Selector Dip Switch, page 2.

THE MICROPROCESSOR IS FACTORY PROGRAMMED WITH THE FOLLOWING DEFAULT SETTINGS

PROGRAM NUMBER	CONTROL FUNCTIONS	DEFAULT SETTING	NEW SETTINGS			
			Date	Setting	Date	Setting
1	TYPE OF SYSTEM	dHOT				
2	OUTDOOR START TEMPERATURE	60° F				
3	DESIGN SUPPLY TEMPERATURE	180° F				
4	SPACE HEAT STAGES	8				
5	OUTDOOR DESIGN TEMPERATURE	0° F				
6	SPACE DESIGN TEMPERATURE	70° F				
7	SET-BACK	INACTIVE				

These default inputs can be viewed and changed when power is supplied to the panel. If changes are necessary, list them in the above chart under NEW SETTING. Go directly to that operation number and make only those changes.

TO VIEW AND MAKE CHANGES, move the **SET/RUN** switch to the **SET** position and follow the programs below:

1. TO VIEW - TYPE OF SYSTEM - HOLD IN TYPE OF SYSTEM button, and observe **dHOT**, (factory default).

TO CHANGE - HOLD IN **TYPE OF SYSTEM** button
PRESS the # key.
HOLD IN **TYPE OF SYSTEM** button, each time you press and release the # key, the **TYPE OF SYSTEM** changes in the visual display window.
HOT - for space heating only.
d HOT - space heating with domestic hot water.
SET - DO NOT use.
dSET - DO NOT use.
Select **HOT** or **dHOT**.

TO CHECK SETTING - PRESS **TYPE OF SYSTEM** button and observe.

2. TO VIEW - OUTDOOR START TEMP. - PRESS OUTDOOR START TEMP. button and observe 60°F (factory default).

TO CHANGE - HOLD IN **OUTDOOR START TEMP.** button.
PRESS the # key.

HOLD IN **OUTDOOR START TEMP.** button. Enter

desired setting. Example [6] [5] = 65°F
RELEASE the **OUTDOOR START TEMP.** button.
TO CHECK SETTING - PRESS **OUTDOOR START TEMP.** button and observe.

3. TO VIEW - DESIGN SUPPLY TEMP. - PRESS DESIGN SUPPLY TEMP. button and observe 180°F (factory default).

TO CHANGE - HOLD IN **DESIGN SUPPLY TEMP.** button.
PRESS the # key.
HOLD IN - **DESIGN SUPPLY TEMP.** button, enter desired setting. Example [2] [0] [0] = 200°F
RELEASE the **DESIGN SUPPLY TEMP.** button.
TO CHECK SETTING - PRESS **DESIGN SUPPLY TEMP.** button and observe.

4. TO VIEW - SPACE HEAT STAGES - PRESS SPACE HEAT STAGES button and observe 8 (factory default).

TO CHANGE - HOLD IN **SPACE HEAT STAGES** button
PRESS the # key.

HOLD IN **SPACE HEAT STAGES** button, enter desired setting. Example [6] = 6 stages.

RELEASE the **SPACE HEAT STAGES** button.
TO CHECK SETTING - PRESS **SPACE HEAT STAGES** button and observe.

NOTE: Space heat stages are the number of active stages, not the number of modules. Any number of domestic hot water modules = one stage (# 8) in a **dHOT type of system**. Example: system with 5 space heat modules and 2 dhw modules; one stage assigned to each space heat module and stage #8 used for the 2 dhw modules, the number of active stages on the panel = 6.

5. TO VIEW - **OUTDOOR DESIGN TEMP.** - PRESS **OUTDOOR DESIGN TEMP.** button and observe **0°F** (factory default).

TO CHANGE - HOLD IN **OUTDOOR DESIGN TEMP.** button.

0°F AND HIGHER

PRESS the # key.
HOLD IN **OUTDOOR DESIGN TEMP.** button, enter desired setting. Example [1] [0] = **10°F**
RELEASE the **OUTDOOR DESIGN TEMP.** button.

BELOW 0°F

PRESS the # key.
PRESS the * key.
HOLD IN **OUTDOOR DESIGN TEMP.** button, enter desired setting. Example [1] [0] = **-10°F**
RELEASE the **OUTDOOR DESIGN TEMP.** button.

TO CHECK SETTING - PRESS **OUTDOOR DESIGN TEMP.** button and observe.

6. TO VIEW - **SPACE DESIGN TEMP.** - PRESS **SPACE DESIGN TEMP.** button and observe **70°F**.

TO CHANGE - HOLD IN **SPACE DESIGN TEMP.**
PRESS the # key.
HOLD IN **SPACE DESIGN TEMP.** button, enter desired setting. Example [7] [5] = **75°F**
RELEASE the **SPACE DESIGN TEMP.** button.
TO CHECK SETTING - PRESS **SPACE DESIGN TEMP.** button.

TO RETURN TO THE FACTORY DEFAULT SETTINGS

(with the **SET/RUN** switch in the **SET** position.)
HOLD IN **TYPE OF SYSTEM** - button.
PRESS the # key.
HOLD IN **TYPE OF SYSTEM** button, each time you press and release the # key, the **TYPE OF SYSTEM** changes in the visual display window.
When **dHOT** is displayed (continuing to hold in the type of system button) press the **RESET** button.
This will restore all the panel's inputs, back to the factory settings.

WHEN THE DESIRED SETTINGS ARE COMPLETE, PROCEED TO SETBACK PROGRAMMING ON PAGE 16. IF NO SETBACK IS DESIRED, MOVE THE SET/RUN SWITCH TO THE RUN POSITION.

PROGRAMMING FOR SETPOINT OPERATION

In setpoint operation, the SC2000 maintains a constant supply water temperature, regardless of space or outdoor temperatures.

DIP SWITCHES

LEAD-LAG	STD
NO SENSOR	SPACE SENSOR
DEG F	DEG C

Select desired operations from the dip switch selections above and move the dip switch on the panel to that position (the NO SENSOR/SPACE SENSOR switch is inoperative in set point operation).

NOTE: See OPERATION SELECTOR DIP SWITCH on page 2.

TO PROGRAM FOR SETPOINT OPERATION, move the SET/RUN switch to the SET position and proceed with

the following programs.

- A. Informs the microprocessor that a SET or dSET operation is being programmed.**

HOLD IN - **SPACE HEAT STAGES** button.
PRESS the * key.
PRESS the # key. Observe 0
RELEASE the **SPACE HEAT STAGES** button.

- B. Programs the type of system used - Factory default dHOT.**

TO VIEW - **TYPE OF SYSTEM** - HOLD IN **TYPE OF SYSTEM** button, and observe **dHOT**, (factory default).

TO CHANGE - HOLD IN **TYPE OF SYSTEM** button
PRESS the # key.
HOLD IN **TYPE OF SYSTEM** button, each time you press and release the # key, the **TYPE OF SYSTEM**

changes in the visual display window.

HOT - DO NOT use

dHOT - DO NOT use.

SET - for constant supply water temperature.

dSET - for constant supply water temperature with domestic hot water.

Select **SET** or **dSET**.

TO CHECK SETTING - PRESS **TYPE OF SYSTEM** button and observe.

C. Programs the number of Space Heating Stages -
Factory default 8.

TO VIEW **SPACE HEAT STAGES** - PRESS **SPACE HEAT STAGES** button and observe 8 (factory default).

TO CHANGE - HOLD IN **SPACE HEAT STAGES** button
PRESS the # key.

HOLD IN **SPACE HEAT STAGES** button, enter desired setting. Example [6] = 6 stages.

RELEASE the **SPACE HEAT STAGES** button.

TO CHECK SETTING - PRESS **SPACE HEAT STAGES** button and observe.

NOTE: Space heat stages are the number of active stages, not the number of modules. Any number of domestic hot water modules = one stage (# 8) in a **dHOT** type of system. Example: system with 5 space heat modules and 2 dhw modules; one stage assigned to each space heat module and stage #8 used for the 2 dhw modules, the number of active stages on the panel = 6.

D. Programs the SUPPLY WATER TEMPERATURE
(Range 100°F - 220°F) Factory default 220°F.

TO PROGRAM - HOLD IN **OUTDOOR DESIGN TEMP.** button.

PRESS the * key.

PRESS the # key. Observe **0**

HOLD IN **OUTDOOR DESIGN TEMP.** button, enter desired setting. Example [1] [4] [0] = **140°F**

RELEASE the **OUTDOOR DESIGN TEMP.** button.

WHEN THE SETTINGS ARE COMPLETE, PROCEED TO SETBACK PROGRAMMING ON PAGE 16. IF NO SET — BACK IS DESIRED, MOVE THE SET/RUN SWITCH TO THE RUN POSITION.

TO VIEW SENSOR READINGS

These readings can be viewed while the panel is in operation.

1. MOVE THE SET/RUN SWITCH TO THE RUN POSITION.

2. OUTDOOR TEMPERATURE (actual)

HOLD IN **OUTSIDE START TEMP.** button.

PRESS the # key.

OBSERVE

3. SUPPLY WATER TEMPERATURE (actual)

When no space sensor is used

SUPPLY TEMPERATURE IS THE NORMAL DISPLAY IN THE WINDOW.

When space sensor is used

HOLD IN **DESIGN SUPPLY TEMP.** button.

PRESS the # key.

OBSERVE

4. SPACE TEMPERATURE (actual)

When space sensor is used

SPACE TEMPERATURE IS THE NORMAL DISPLAY IN THE WINDOW.

When no space sensor used

THE **SPACE TEMPERATURE** IS NOT AVAILABLE.

SENSOR CALIBRATION

- After all wiring has been completed, space, supply water and outdoor start sensors should be calibrated to compensate for variations in sensor wire length and resistance.
- Use the 1000 ohm precision resistor provided with the Controller.
- Locate set-run switch, NO SENSOR/SPACE SENSOR switch (at operation selector switches), keypads and sensor adjustment pots (see illustration on page 2).
- MOVE SET-RUN SWITCH TO **RUN** POSITION.

NOTICE: TURN OFF POWER WHEN HANDLING WIRING. TURN ON POWER WHEN CALIBRATING.

SPACE SENSOR (if used)

- MUST BE CALIBRATED.
- Remove wires from the sensor at the sensor location, or panel on short runs. On long runs, connect the (1000 ohm) precision resistor to the sensor wires at the sensor location. On short runs (less than 100 ft.) connect the resistor to sensor terminals on the panel.
- Set NO SENSOR/SPACE SENSOR switch to SPACE SENSOR position.
- Press the RESET button and wait 6-10 seconds for the display to show the current Space Temp. reading.
- A properly calibrated reading is 70°F. If the reading needs to be increased, turn the space temp. calibration pot (see Description of SC2000 Components, pg. 3) *slightly* in the counterclockwise direction. Clockwise to decrease the reading. It is important to move the calibration adjustment a small amount each time.
- Press the RESET button and wait 6-10 seconds to see the new reading.
- Repeat until the display shows 70°F.
- Remove resistor and reconnect wires.

SUPPLY WATER SENSOR

- Calibration recommended.
- Remove wires from the sensor at the sensor location, or panel on short runs. On long runs, connect the (1000 ohm) precision resistor to the sensor wires at the sensor location. On short runs (less than 100 ft.) connect the resistor to sensor terminals on the panel.

- Set NO SENSOR/SPACE SENSOR switch to NO SENSOR position.
- Press the RESET button and wait 6-10 seconds for the display to show the current Water Temp. reading.
- A properly calibrated reading is 70°F. If the reading needs to be increased, turn the outdoor air temp. calibration pot (see Description of SC2000 Components, pg. 3) *slightly* in the counterclockwise direction. Clockwise to decrease the reading.
- Press the RESET button and wait 6-10 seconds to see the new reading.
- Repeat until the display shows 70°F.
- At sensor, remove resistor and reconnect wires.
- If the Space Temperature Sensor is being used, remember to return the NO SENSOR/SPACE SENSOR switch to the space sensor position.

OUTDOOR SENSOR

- Calibration recommended.
- Remove wires from the sensor at the sensor location, or panel on short runs. On long runs, connect the (1000 ohm) precision resistor to the sensor wires at the sensor location. On short runs (less than 100 ft.) connect the resistor to sensor terminals on the panel.
- NO SENSOR/SPACE SENSOR switch can be in either position.
- Press the RESET button and wait 6-10 seconds for the display light up.
- Press and hold the OUTDOOR START TEMP. button and the # button to display the current Outdoor Temp. reading.
- A properly calibrated reading is 70°F. If the reading needs to be increased, turn the outdoor air temp. calibration pot (see Description of SC2000 Components, pg. 3) *slightly* in the counterclockwise direction. Clockwise to decrease the reading.
- Press the RESET button, wait 6-10 seconds, then press and hold the OUTDOOR START TEMP. button and the # button to see the new reading.
- Repeat until the display shows 70°F.
- Remove resistor and reconnect wires.

SENSOR CALIBRATION NOTES:

When wiring to sensors is 100 feet OR LESS, the sensors usually do not require calibration. If the control system does not perform properly, the calibration of the sensors outlined above MUST be performed.

FINE TUNING THE SC2000

This control has two additional functions that can be fine tuned. The factory default values for these settings will function well in the overwhelming majority of applications. DO NOT adjust unless absolutely necessary.

THE MICROPROCESSOR IS FACTORY PROGRAMMED WITH THE FOLLOWING DEFAULT SETTINGS:

PROGRAM NUMBER	CONTROL FUNCTIONS	DEFAULT SETTING	NEW SETTINGS			
			Date	Setting	Date	Setting
1	HIGH CLAMP	220°F				
2	LOW CLAMP	110°F				

If changes are necessary, list them in the above chart under NEW SETTINGS. Go directly to that operation number and make only that change.

1. HIGH CLAMP - the maximum allowable operating water temperature. (Factory default 220°F).

During operation in the **HOT** or **dHOT** mode, the system supply water temperature will not be allowed to operate above this setting. The range of this setting is 100°F to 220°F. This function is **INOPERATIVE IN SET** or **dSET** mode of operation.

- TO VIEW:
(SET/RUN SWITCH MUST BE IN THE SET POSITION)

HOLD IN **OUTDOOR DESIGN TEMP.** button.
PRESS the * key.
Observe **220**
RELEASE the **OUTDOOR DESIGN TEMP.** button.

- TO CHANGE:
HOLD IN **OUTDOOR DESIGN TEMP.** button.
PRESS the * key.
PRESS the # key, enter desired setting.
Example [2] [0] [0] = **200°F**
RELEASE the **OUTDOOR DESIGN TEMP.** button.

2. LOW CLAMP - the minimum allowable operating water temperature. (Factory default 110°F).

During operation in the **HOT** or **dHOT** mode, the system supply water temperature will not be allowed to operate below this setting. The range of this setting is 110°F to 160°F. This function is **INOPERATIVE IN SET** or **dSET** mode of operation.

- TO VIEW:
(SET/RUN SWITCH MUST BE IN THE SET POSITION)

HOLD IN **SPACE HEAT STAGES** button.
PRESS the * key.
Observe **110**
RELEASE the **SPACE HEAT STAGES** button.

- TO CHANGE:
HOLD IN **SPACE HEAT STAGES** button.
PRESS the * key.
PRESS the # key, enter desired setting.
Example [1] [2] [0] = **120°F**
RELEASE the **SPACE HEAT STAGES** button.

SETBACK PROGRAMMING

INOPERATIVE IN SET or dSET MODE

Write Programming Down First: If no keypad buttons are pressed for 3 minutes during programming, the Controller will shut off the setback function and return to normal operation. To help prevent such an interruption, a blank form is provided on page 18, to write down and record your programming.

Functions Available

- Setting actual day of week and time of day.
- Setting daily or weekly schedules.
- Clearing, viewing and copying schedules.

Heating Plant Can Remain In Operation: Modules firing will remain on, but Controller will not add or delete stages until setback programming has been completed.

Entering Days Of Week: Must use numbers for Monday through Sunday - Monday being 1 and Sunday being 7.

Entering Time Of Day: Must use the four-digit military time.

Example: 6:00 AM is 0600; 12:00 Noon is 1200; 6:00 PM is 1800; 11:00 PM is 2300; Midnight is 0000.

Properly Entered Format: Display will show four dashes (----) for 2 seconds and then return to displaying day and time of day.

Improperly Entered Format: Display will show "BAD" for 2 seconds and return to day and time of day.

Correcting Error During Programming: Simply press the "#" button and re-enter correct format.

How To Start (and Finish) Programming

- Make sure Set/Run switch is in "RUN" position.
- Press Set-Back button.
- Setback indicator light will turn on and then flash until programming is completed; display will alternate between day and time of day.
- When done, press Set-Back button; light will go OFF.

TO SET THE DAY OF THE WEEK	PRESS EACH KEY ONCE	DISPLAY WILL SHOW
Where "?" is shown, enter the number corresponding to the day of the week. Monday is 1, Tuesday is 2, etc... Sunday is 7.	#	[]
	8	d_
	?	d?
	*	- - - -

TO SET THE TIME OF THE DAY	
Where "?" is shown, enter the number corresponding to the military time. Example: for 6:30 PM, enter 1 8 3 0 .	
#	PRESS EACH KEY ONCE
9	[]
?	[] [] [] []
*	[] [] [] []

THE WEEKLY SCHEDULE

The Weekly Schedule is explained here by way of example: The desired operation is to have a 70°F Space Temperature from 6:30 AM to 6:00 PM from Monday through Friday, and 50°F Space Temperature at all other times.

The required schedule will have a number of program lines on each day of the week. Day #1 (Monday) will have a line #1 at 0630 (6:30 AM) calling for zero setback. Line #2 will call for 50°F at 1800 (6:00 PM). These same two lines are duplicated for each day from #1 (Monday) through day #5 (Friday).

Note that the Setback that occurs at 6 PM on Friday is "turned off" by the 6:30 AM entry on Monday. Note also that when the schedule needs a "setback", the program line will call for a temperature input. When the schedule calls for setback to be "turned off" the program line will include a zero instead of a temperature.

The following program lines implement this weekly schedule.

- | | | | | | | | | | | | |
|---|---|---|---|---|--|---|---|---|---|---|--|
| # | 6 | 1 | 1 | 0 | 6 | 3 | 0 | 0 | 0 | * | This line ENDS setback every day at 6:30. |
| # | 6 | 1 | 2 | 1 | 8 | 0 | 0 | 5 | 0 | * | This line BEGINS setback everyday at 6 PM. |
| # | 0 | 6 | 0 | * | This line CLEARS the Saturday program. | | | | | | |
| # | 0 | 7 | 0 | * | This line CLEARS the Sunday program. | | | | | | |

TO MAKE A SINGLE ENTRY FOR ONE DAY

5 ? day ? line# ? time ? time ? time ? temp ? temp *

At the first ? put it the day of the week, for instance 3 for Wednesday. For the second ? put in the entry number. If this is the first entry for that day's programming, enter a 1. The next group of ????'s are for the time - remember, the time is in 24 hour "military" form. "1800" means 6:00 PM.

The next ??'s are for the setback temperature:

- If the space temperature sensor is being used, put in the space temperature to be held during setback. If the space temperature should be 50 degrees during the setback, enter 50.
- If the space temperature sensor is NOT being used, put in the amount that the heating supply water temperature should be reduced. For instance, a system may be at 170°F at the moment just before setback and it is desired to reduce that by 25°F to 155°F. Enter 25.
- To Turn Off The Setback, that is, to end a setback period that was initiated by an earlier entry, put in 00.

TO ENTER A SINGLE LINE FOR MULTIPLE DAYS

6 ? day ? line# ? time ? time ? time ? temp ? temp *

This entry is identical to entering a single line for ONE day except:

- The entry begins with # 6 instead of # 5.
- This entry adds this program line to the day indicated and every day following up to day 7.

TO COPY AN ENTIRE DAY'S PROGRAM TO ANOTHER DAY

7 ? day ? day *

For the first ? put in the number of the day to be copied. For the second ?, put in the day being copied to. To copy Monday's programming to Wednesday, the entire line is # 7 1 3 *. Note that if there are several lines of programming in the day to be copied, they will ALL be copied to the new day.

TO VIEW A SINGLE DAY'S PROGRAM

0 ? day *

Replace the question mark with the day of the week to view that one day's programming. The display will show a sequence of numbers: the day and entry number, the time and the setback temperature. This sequence will repeat for each entry in that day's programming.

TO SET THE SYSTEM INTO A CONSTANT SETBACK

2 ? temp ? temp *

For the ??'s, put in the temperature to set back to. If the system is at 70 and it is desired to set it to 50, enter # 2 5 0 *. When entering the temperature, if the space temperature sensor is being used, enter the desired space temperature. If the space sensor is not used, enter the amount by which the supply water temperature is to be reduced.

The system will immediately enter setback mode and remain there until # 1 * is entered.

TO RESET THE SYSTEM TO NORMAL PROGRAMMED OPERATION

1 *

To Return the system to normal operation after entering # 2 Constant Setback (above) or # 3 or # 4 Setback Disable (below), enter # 1 *.

TO DISABLE SETBACK FOR THREE HOURS

3 *

When # 3 * is entered, the system immediately leaves setback (if applicable) and ignores all setback programming for the next three hours. Programmed operation resumes automatically after 3 hours. This can be cancelled at any time by entering # 1 *.

TO DISABLE SETBACK INDEFINITELY

4 *

When # 4 * is entered, the system immediately leaves setback (if applicable) and ignores all setback programming until # 1 * is entered.

TO CLEAR ALL PROGRAMMING

0 *

This clears the setback programming, but does not effect the day of week or the time of day.

TO CLEAR A SINGLE DAY'S PROGRAM

0 ? day 0 *

Replace the question mark with the day of the week to clear that one day's programming.

SAMPLE SETBACK SCHEDULE FORM

All entries start with [#] + [5 or 6] and end with [*].
See detailed instructions on Page 16.

DAY _ SETBACK PROGRAM SCHEDULE

___ + _____ + _____ + _____
Day Schedule Time Temp

___ + _____ + _____ + _____

___ + _____ + _____ + _____

___ + _____ + _____ + _____

___ + _____ + _____ + _____

___ + _____ + _____ + _____

___ + _____ + _____ + _____

___ + _____ + _____ + _____

DAY _ SETBACK PROGRAM SCHEDULE

___ + _____ + _____ + _____
Day Schedule Time Temp

___ + _____ + _____ + _____

___ + _____ + _____ + _____

___ + _____ + _____ + _____

___ + _____ + _____ + _____

___ + _____ + _____ + _____

___ + _____ + _____ + _____

___ + _____ + _____ + _____

DAY _ SETBACK PROGRAM SCHEDULE

___ + _____ + _____ + _____
Day Schedule Time Temp

___ + _____ + _____ + _____

___ + _____ + _____ + _____

___ + _____ + _____ + _____

___ + _____ + _____ + _____

___ + _____ + _____ + _____

___ + _____ + _____ + _____

___ + _____ + _____ + _____

DAY _ SETBACK PROGRAM SCHEDULE

___ + _____ + _____ + _____
Day Schedule Time Temp

___ + _____ + _____ + _____

___ + _____ + _____ + _____

___ + _____ + _____ + _____

___ + _____ + _____ + _____

___ + _____ + _____ + _____

___ + _____ + _____ + _____

___ + _____ + _____ + _____

TROUBLESHOOTING THE SC2000

1. **PANEL WILL NOT ENERGIZE** (visual display is blank)
 - A. Check power on terminals 1 and 2. Should read 120V AC.
If O.K. proceed to step B.
If not check switches and circuit breaker going to the panel.
 - B. Check power on terminals 9 and 2. Should read 120V AC.
 - a. If no power, check L.W.C.O., and manual high limit circuits to make sure they are closed.
 - b. If 120V is present on terminals 9 and 2 with a blank visual display, the panel could be defective. Contact the factory.
2. **PANEL WILL NOT CYCLE ON** (dotted line, or the words set/run flashing in the visual display window).
 - A. **Set/Run** switch in the set position. Move the switch to the **Run** position.
3. **PANEL WILL NOT CYCLE ON** (normal reading in the visual display) **HOT** and **dHOT** systems.
 - A. The current outdoor temperature must be lower than the panel's start temperature setting.
 - B. Check the calibration of the sensors. (see calibrating sensors)
4. **Error 1 in the visual display.**
 - A. Check the outdoor sensor wiring for short or open circuit.
5. **Error 2 in the visual display.**
 - A. Check the supply water sensor wiring for open or short circuit.
6. **Error 3 in the visual display.**
 - A. Check the space sensor wiring for open or short circuit.

If the problem is related to:
Supply water temperature too low
Modules cycling too rapidly
Supply water temperature at a constant high temperature,
Space temperature not correct

Reset the panel back to factory default settings (see pg. 12) and reprogram settings that need to differ from the default (see page 11). Then recheck system operation. If the problem continues, see items 7 through 10 below.
7. **SUPPLY WATER TEMPERATURE TOO LOW.**
 - A. Check if panel is in a setback mode. (see page 16)
 - B. Check HIGH CLAMP setting. It may be set at below the temperature that the system requires. (see page 8)
 - C. Check the calibrations of the outdoor and supply sensors.
8. **RAPID CYCLING OF THE MODULES.**
 - A. Check programming. Values used must be appropriate to the system and climate.
9. **SUPPLY WATER AT A CONSTANT HIGH TEMPERATURE.**
 - A. Panel may be programmed for SETPOINT operation (see page 12)
 - B. LOW CLAMP set at a high temperature. (see page 15)
10. **SPACE TEMPERATURE NOT HOLDING AT SETTING.** (space sensor installed)
 - A. Check dip switch on panel, make sure it is set for SPACE SENSOR. (see page 2)
 - B. Check the calibration of the space sensor. (see page 14)

SC2000 CONTROLLER SPECIFICATIONS AND DIMENSIONS

OPERATING VOLTAGE: 105 - 135VAC50/60 Hz @ 20 watts maximum.

OPERATING TEMPERATURE: +32°F to +122°F in Operation
-13°F to +165°F in Storage

RELAYS: All relays are UL recognized, plug-in type with spring clip retainers
12V DC coils - DPDT. Contacts rated 10A resistive, 1/3 HP 125/250V

RELAYS K1 THROUGH K7: Contacts arranged DPST

RELAY K8: Contacts arranged SPDT

RELAY K9: Contacts arranged SPST
K9 is energized when outdoor temperature sensor reading is less than or equal to programmed Outdoor Start Temperature, de-energizes at Outdoor Start Temperature +3°F.

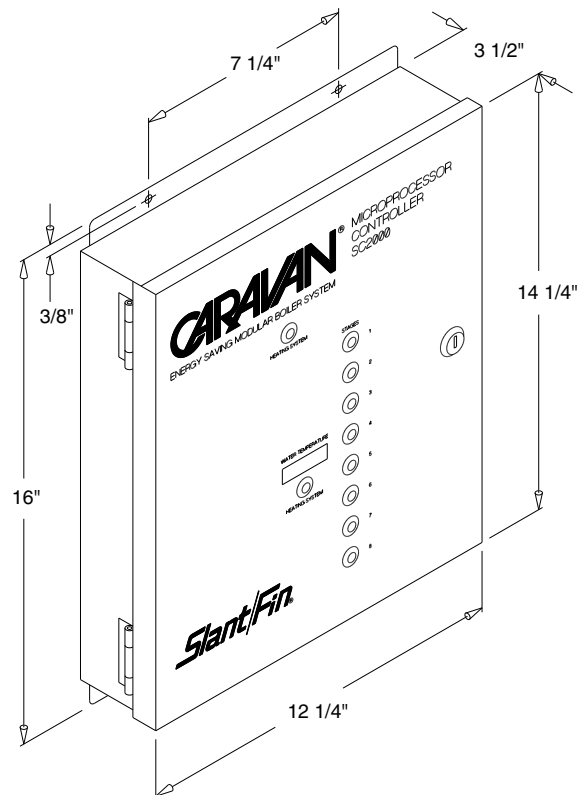

©Slant/Fin Corp. 2003.

Slant/Fin® SLANT/FIN CORPORATION, Greenvale, N.Y. 11548 • Phone: (516) 484-2600

FAX: (516) 484-5921 • Canada: Slant/Fin LTD/LTEE, Mississauga, Ontario

www.slantfin.com