



HydroStat 3200-Plus for Slant Fin Boilers

Part Numbers:
48-3200, 48-3200-03
and 48-3200-04

120 VAC Input / 24 VAC Burner Circuit

PATENT NOS.
8,391,708; 7,891,572; 8,844,834;
Others Pending

INSTALLATION INSTRUCTIONS and OPERATING MANUAL

- **Saves Fuel** – Features Thermal Targeting™ technology and Thermal Pre-Purge capability
- **Outdoor Reset Ready** – Provides Outdoor Reset and Warm Weather Shut-Down capability with the addition of Hydrolevel OS-100 Outdoor Sensor Kit (sold separately)
- **Operating Indicators** – LEDs, Dynamic Display and Test Button provide continual and on-demand status checks
- **Prioritizes Domestic Hot Water** – Gives priority to low limit setting or to calls from indirect water heater

Three Function Design

Temperature Limit Control

Designed for cold start and tankless coil boilers.

Low Water Cut-Off

Provides protection against potentially dangerous low water conditions when installed with the Hydrolevel Electro-Well™.

Boiler Reset Control

- **Thermal Targeting** – On-board microprocessor adjusts boiler temperature based on heating demand.
- **Outdoor Reset Ready** – Compatible with Hydrolevel OS-100 Outdoor Sensor Kit (sold separately) for outdoor reset and warm weather shut-down functionality.

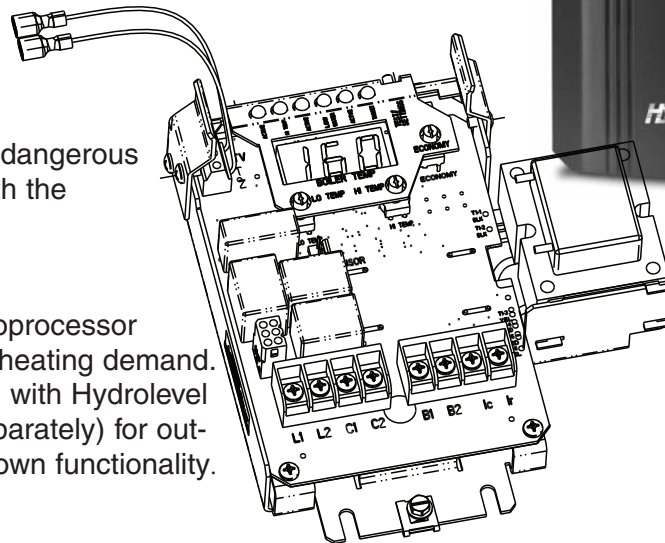

48-3200-03 shown



WARNING **Electrical shock hazard.** To prevent electrical shock, death or equipment damage, disconnect power supply before installing or servicing control. Only qualified personnel may install or service this control in accordance with local codes and ordinances. Read instructions completely before proceeding.

CAUTION To prevent serious burns, boiler should be thoroughly cooled before installing or servicing control.

WARNING **Frozen pipes/water damage.** Central heating systems are prone to shut down as a result of power or fuel outages, safety related fault conditions or equipment failure. Installation of freeze protection monitoring or other precautions is recommended for unattended dwellings in climates subject to sustain below-freezing temperatures.

LIMITED MANUFACTURER'S WARRANTY

We warrant products manufactured by Hydrolevel Company to be free from defects in material and workmanship for a period of two years from the date of manufacture or one year from the date of installation, whichever occurs first. In the event of any claim under this warranty or otherwise with respect to our products which is made within such period, we will, at our option, repair or replace such products or refund the purchase price paid to us by you for such products. In no event shall Hydrolevel Company

be liable for any other loss or damage, whether direct, indirect, incidental or consequential. This warranty is your EXCLUSIVE remedy and shall be IN PLACE OF any other warranty or guarantee, express or implied, including, without limitation, any warranty of MERCHANTABILITY or fitness for a particular purpose. This warranty may not be assigned or transferred and any unauthorized transfer or assignment thereof shall be void and of no force or effect.



126 Bailey Road • North Haven, CT 06473 • Phone (203) 776-0473 • FAX (203) 764-1711 • www.hydrolevel.com

SPECIFICATIONS FUEL SMART HYDROSTAT MODEL 3200-Plus

Input voltage	120 VAC, 60 HZ
Burner contacts	30 VA @ 24 VAC
Circulator contacts	5.8 FLA, 34.8 LRA @ 120 VAC
Operating range – low limit	Off or 110°F (43°C) - 200°F (93°C)
Operating range – high limit	100°F (38°C) - 220°F (104°C)
Operating range – differentials	Automatic
Thermostat heat anticipator setting	0.2A

WIRING

⚠ WARNING Electrical shock hazard. To prevent electrical shock, death or equipment damage, disconnect power supply before installing or servicing this control.

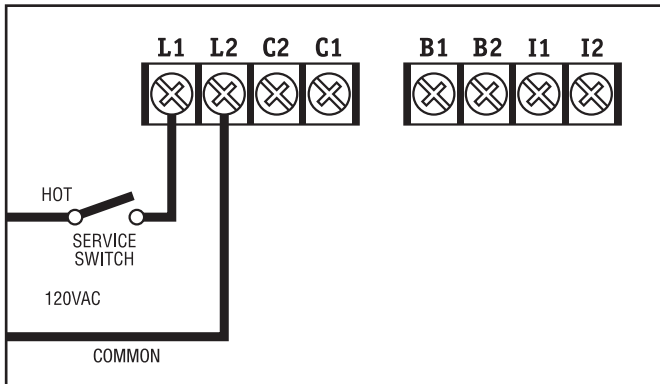

STEP 1 Connect 120 VAC Hot to terminal L1. Connect 120 VAC Common to terminal L2. Disconnect means and overload protection as required (provided by others).

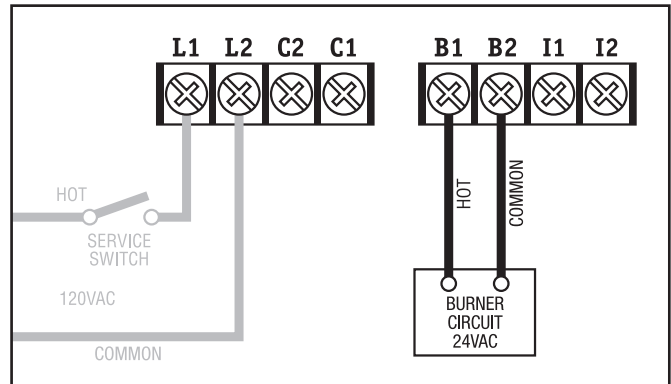

STEP 2 Connect the burner circuit to B1-B2. (B2 is common.)

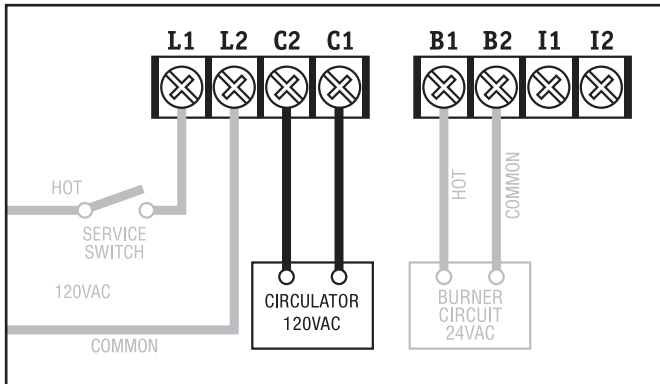

STEP 3 Connect the circulator to C1-C2. (C2 is common.)

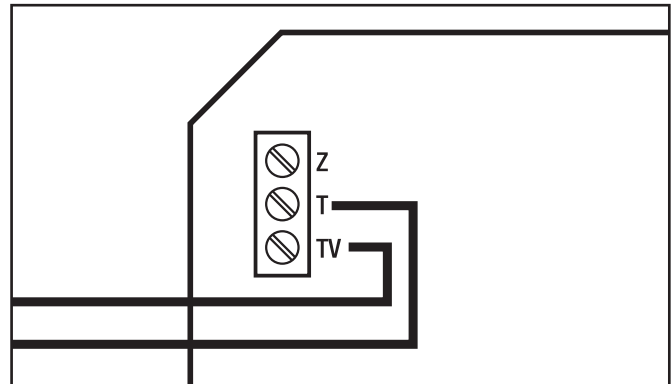

STEP 4 Connect the thermostat to T/TV.

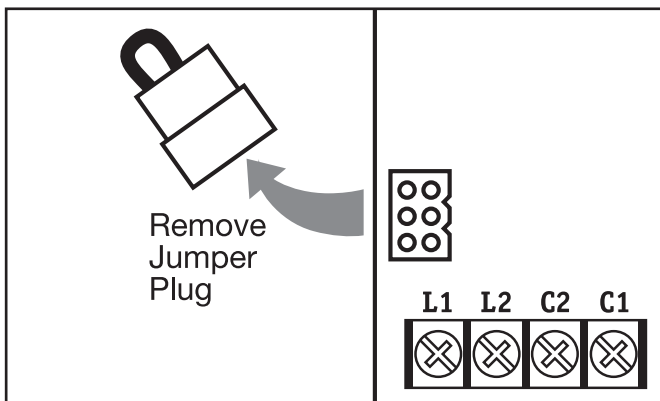

STEP 5 If the boiler is equipped with a plug-in style vent damper, unplug the factory installed jumper from the receptacle on the circuit board and replace it with the vent damper plug.

SETTING THE CONTROL

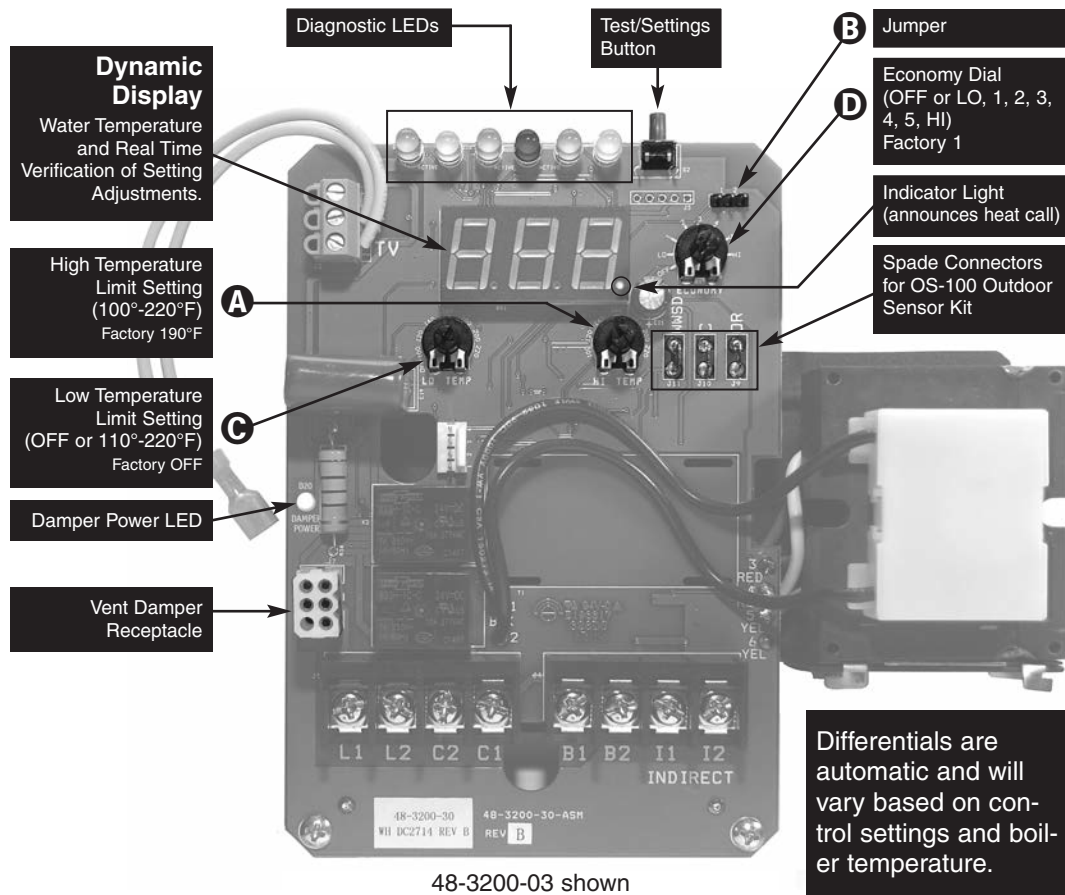

Differentials are automatic and will vary based on control settings and boiler temperature.

Note: The high limit differential can be adjusted when the economy feature is turned off. See Optional Features on page 7.

NOTE: Settings can be checked using the TEST/SETTINGS Button. See page 9 for details.

Setting the High Limit

The high limit is factory set at 190°F. To adjust, turn the HI TEMP Dial **A** until the desired setting is displayed. (Setting range: 100°-220°F)

Setting the Low Limit

The low limit is designed to maintain temperature in boilers equipped with tankless coils used for domestic hot water. The low limit is factory set to OFF. Prior to adjusting, remove the jumper (not equipped on all units) **B**. Then turn the LO TEMP Dial **C** clockwise until the desired temperature is displayed. For proper operation, the low temperature limit setting should be at least 10° below the high limit setting. **NOTE:** For cold start operation, the low limit must be turned OFF. **IMPORTANT:** If low limit temperature cannot be set above 140°F, remove jumper **B**. (Setting range: OFF or 110°-220°F).

Setting the Economy Feature

The Economy Feature is factory set for a 1 zone heating system. To adjust, turn the ECONOMY Dial **D** until the number displayed equals the number of heating zones. **Do not include indirect water heaters in the number of heating zones.** The Economy Feature conserves fuel by reducing boiler

temperature (see “How Thermal Targeting Works” on page 5). If the heating system is unable to supply needed heat to the house, the ECONOMY Dial should be turned to a lower setting (example: In a three zone house, turn the dial to 2 or 1). Conversely, if the boiler provides adequate heat, added fuel savings can be achieved by selecting a higher setting (example: 4 or 5). If the heating and indirect water heater signals were not separated when wiring the control, the Economy Feature should be turned OFF to ensure the boiler supplies adequate temperature to heat the indirect tank.

SETTING

- OFF** Disables economy function. Will allow boiler to fire until hi-limit temp is reached and re-fire with a 10° subtractive differential.
- LO** Provides lowest level of fuel savings. Use this setting only if the house does not stay warm at higher settings.
- 1** Recommended setting for single zone systems
- 2** Recommended setting for Two zone systems
- 3** Recommended setting for Three zone systems
- 4** Recommended setting for Four zone systems
- 5** Recommended setting for Five zone systems
- Hi** Provides highest level of fuel savings

SYSTEM START-UP

At initial start up, with the Economy Feature active, the control establishes a 145°F target temperature. To test the high limit shut-off function, the Economy Dial must be turned to OFF. Once tested, restore the Economy setting. If the heating demand is high, the target will increase over time to satisfy the heat load.

NOTE:

- *Smart DHW Priority:* During a call from an indirect water heater, the control will de-energize the circulator contacts (C1/C2) to heat only the indirect tank ensuring an adequate supply of domestic hot water. The control will re-energize the circulator when the indirect tank is satisfied or if the boiler temperature reaches 170°F. If the indirect call continues for 45 minutes, the control will override the priority function energizing the circulator to provide space heating.

HOW THERMAL TARGETING WORKS

Thermal Targeting technology analyzes thermostat activity and continually evaluates how much heat the house requires. When it is very cold outside, the heat demand is high and the Fuel Smart HydroStat will raise the boiler's Target temperature to provide needed heat to the home. When the outside temperature is milder, the heat demand is lower. During these periods, the Fuel Smart HydroStat will lower the boiler's Target temperature – saving fuel – while continuing to provide comfort to the house.

SENSOR INSERTION

IMPORTANT – Sensor must be inserted all the way into the well for proper operation.

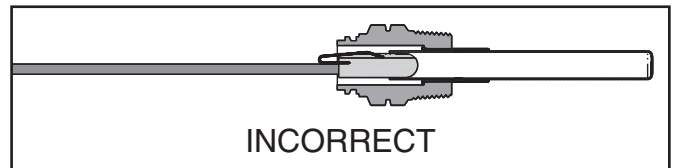
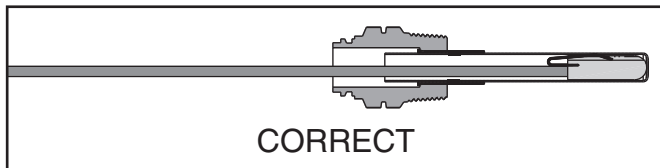

OUTDOOR SENSOR KITS

Hydrolevel's optional Outdoor Sensor Kits automatically activate outdoor reset functionality and warm weather shutdown capability when plugged into the Fuel Smart HydroStat control. These kits are available separately at Hydrolevel distributors.

Part No.	Description
48-140	Model OS-100 Outdoor Sensor Kit
48-145	Model OS-200 Wireless Outdoor Sensor Kit

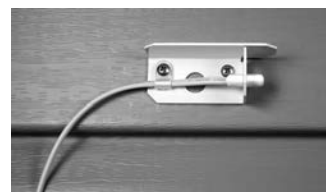

Model OS-100



Model OS-200

OPTIONAL FEATURES

NOTE: The Program Mode – **PRO** – is accessed by turning the LO TEMP dial to a position just above OFF.

Thermal Pre-Purge

Thermal Pre-Purge is designed to maximize boiler efficiency. When activated, the control will supply latent heat that may remain in the boiler from a previous run cycle to the next heating zone that calls. The control monitors how quickly the boiler temperature is declining and activates the burner only when it determines that the latent heat is insufficient to satisfy the call. During the purge cycle, the display will indicate **PUR**. This feature works with single-zone and multi-zone heating systems utilizing circulators or zone valves. No change in wiring is needed.

To activate Thermal Pre-Purge

1. Turn the LO TEMP dial to access the Program Mode – indicated in the display as **PRO**
2. Turn the HI TEMP dial to select feature **1**
3. Push the Test/Settings Button to turn Thermal Pre-Purge **ON** or **OFF**
4. Reset LO TEMP and HI TEMP settings to desired temperatures (see page 4)

Degrees Fahrenheit or Celsius

The control has the ability to operate in degrees Fahrenheit or Celsius. When operating in Celsius, a **C** will appear in the display next to the temperature whenever the temperature is below 100 degrees.

To change between degrees Fahrenheit and degrees Celsius

1. Turn the LO TEMP dial to access the Program Mode – indicated in the display as **PRO**
2. Turn the HI TEMP dial to select feature **2**
3. Push the Test/Settings Button to **C** for Celsius or **F** for Fahrenheit
4. Reset LO TEMP and HI TEMP settings to desired temperatures (see page 4)

Manual Reset Low Water Cut-Off

The low water cut-off operation on the HydroStat can be set to operate in automatic (default) or manual reset mode. When in manual reset mode, the control will shut-down the burner immediately when a low water condition is detected. If the low water condition is sustained for 30 seconds, the low water light will blink, indicating that the control has locked out the burner. The control can only be reset by pushing the Test Settings button on the top of the control. The manual reset feature meets CSD-1 code requirements.

IMPORTANT: The system must be checked by a qualified heating professional prior to resuming operation.

WARNING: DO NOT ADD WATER UNTIL THE BOILER HAS FULLY COOLED.

To activate Manual Reset LWCO mode

1. Turn the LO TEMP dial to access the Program Mode – indicated in the display as **PRO**
2. Turn the HI TEMP dial to select feature **3**
3. Push the Test/Settings Button to **A** for Automatic Reset Mode or **B** for Manual Reset Mode
4. Reset LO TEMP and HI TEMP settings to desired temperatures (see page 4)

To Test the Manual Reset Feature: Press and hold the Test/Settings button located on the top of the control for 30 seconds to simulate a low water condition. After 30 seconds, the Low Water light will blink indicating that the control is locked out. To reset the lock-out condition, press the Test/Settings button momentarily.

MORE OPTIONAL FEATURES ON NEXT PAGE

Circulator Activation Options

When in the default mode, the HydroStat activates the circulator (**C1/C2** contacts) on calls to **T/TV**. The control can be programmed to activate the circulator on calls to **I1/I2** in place of, or in addition to, calls to **T/TV**.

To change how the Circulator is activated

1. Turn the LO TEMP dial to access the Program Mode – indicated in the display as **Pro**
2. Turn the HI TEMP dial to select feature **4**
3. Push the Test/Settings Button to select between the following options:
 - A** - Circulator on **T/TV** call only
 - b** - Circulator on **I1/I2** call only
 - C** - Circulator on both **T/TV** & **I1/I2** calls
4. Reset LO TEMP and HI TEMP settings to desired temperatures (see page 4)

Circulator Hold Off (Enhanced Condensing Protection)

To reduce the potential for condensing, on a call for heat the control will allow the boiler to heat to 125°F prior to energizing the circulator. Once energized, the circulator will remain on for the duration of the heating call unless the boiler temperature drops below 115°F. If this occurs, the circulator will re-energize when the boiler returns to 125°F. Circulator holdoff will expire after 15 minutes.

To activate Circulator Hold Off

1. Turn the LO TEMP dial to access the Program Mode – indicated in the display as **Pro**
2. Turn the HI TEMP dial to select feature **5**
3. Push the Test/Settings Button to turn Circulator Hold Off **on** or **OFF**
4. Reset LO TEMP and HI TEMP settings to desired temperatures (see page 4)

High Limit Differential

When the Economy feature is on, the control's Thermal Targeting feature actively sets varying differentials based on system conditions. This option allows for selecting a 10, 20 or 30 degree fixed differential when the Economy feature is turned OFF. These optional differential settings are subtractive from the HIGH LIMIT setting. **Note:** If the Economy feature is on, this setting will be overridden by the control's Thermal Targeting function.

To change the high limit differential

1. Turn the LO TEMP dial to access the Program Mode – indicated in the display as **Pro**
2. Turn the HI TEMP dial to select feature **9**
3. Push the Test/Settings Button to select a high limit differential of **10**, **20**, or **30**
4. Reset LO TEMP and HI TEMP settings to desired temperatures (see page 4)

RESTORING FACTORY DEFAULT SETTINGS ON NEXT PAGE

OPTIONAL FEATURES continued

Restore Factory Default Settings

To restore all features to the factory default settings (see following chart for default settings)

1. Turn the LO TEMP dial to access the Program Mode – indicated in the display as **Pro**
2. Turn the HI TEMP dial to select feature **dEF**
3. Push the Test/Settings Button to **Y** to reset all features to the default settings.
4. Reset LO TEMP and HI TEMP settings to desired temperatures (see page 4)

Dial Setting	Feature	Options	Description	Default Setting
1	Thermal Pre-Purge	OFF ON	Purge Inactive Purge Active	OFF
2	Fahrenheit or Celsius	F C	Degrees Fahrenheit Degrees Celsius	F
3	LWCO Manual or Automatic Reset	R b	Automatic Reset Manual Reset	R
4	Circulator Options	R b C	Circulator Operation on T/TV call only Circulator Operation on I1/I2 call only Circulator Operation on call from either	R
5	Circulator Hold Off	ON OFF	Circulator Hold Off – Active Circulator Hold Off – Inactive	OFF
6	<i>Not available on this control</i>			
7	<i>Not available on this control</i>			
8	<i>Not available on this control</i>			
9	High Limit Differential	10 20 30	10° Differential 20° Differential 30° Differential	10
dEF	Restore Factory Defaults	Y n	Restore Defaults Do Not Restore Defaults	n

NOTE: If the HydroStat is factory-equipped on a boiler, some options may be set differently from the default settings.

SEE PAGE 4 FOR ADDITIONAL SETTINGS

LED LEGEND and TEST/SETTINGS BUTTON

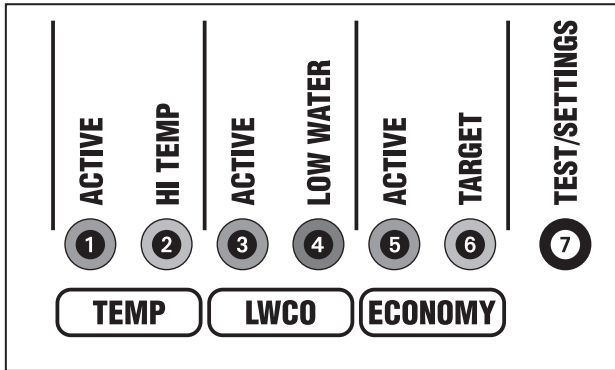

- 1 TEMP ACTIVE** Indicates that the Fuel Smart HydroStat control is powered and that the temperature function is active.
- 2 TEMP HI TEMP** Illuminates when the boiler water temperature reaches the high limit setting. It will remain lit until the water temperature falls 10°. The Fuel Smart HydroStat prevents burner operation while this LED is on. See Differential explanation on page 6.
- 3 LWCO ACTIVE** Indicates that the low water cut-off (LWCO) function of the Fuel Smart HydroStat is active. When the control is installed with a Hydrolevel Electro-Well, this LED will be on at all times when the control is powered. **IMPORTANT:** If the control is installed with a well other than the Electro-Well, this LED will not illuminate indicating that the control is not providing low water cut-off functionality.
- 4 LWCO LOW WATER** Indicates that the boiler is in a low water condition. The HydroStat control will prevent burner operation during this condition. If the LOW WATER light is blinking, the control has been programmed to provide lock-out protection in the event a low water condition is detected (see Manual Reset Low Water Cut-Off on page 8). Pressing the TEST/SETTINGS button will reset the control. **IMPORTANT:** The system must be checked by a qualified heating professional prior to resuming operation.
- WARNING: ALLOW THE BOILER TO FULLY COOL BEFORE ADDING WATER.**
- 5 ECONOMY ACTIVE** Indicates that the Thermal Targeting function is active and the Fuel Smart HydroStat will reduce boiler temperature to conserve fuel. The Economy feature is activated using the ECONOMY dial. (See "How Thermal Targeting Works" on page 7 for more information).
- 6 ECONOMY TARGET** When the Economy feature is active, the Fuel Smart HydroStat continually sets target temperatures below the high limit setting to maximize fuel efficiency. When the boiler water reaches the target temperature, the LED illuminates and the burner will shut down. The boiler water will continue to circulate and heat the house as long as the thermostat call continues. The LED will stay lit until the boiler temperature drops below the differential set point at which point the boiler will be allowed to fire again. See Differential explanation on page 6. **NOTE:** This LED illuminates regularly during normal boiler operation.

7 TEST/SETTINGS Button

To Test Low Water Cut-Off: Press and hold the Test/Settings button for 5 seconds. The display will read LCO.

LWCO TEST LCO

The red Low Water light should illuminate and the burner circuit (B1 and B2) should de-energize. **NOTE:** The control must be installed with a Hydrolevel Electro-Well for low water cut-off functionality (see page 2 for more details).

To View Current Settings: Press and release the Test/Settings Button in short intervals to sequentially display the following settings:

HIGH LIMIT SETTING HL

LOW LIMIT SETTING LL

ECONOMY SETTING ECO

CURRENT TARGET TEMPERATURE 000

The display will return to boiler temperature (default) if Test/Settings Button is not pressed for 5 seconds.

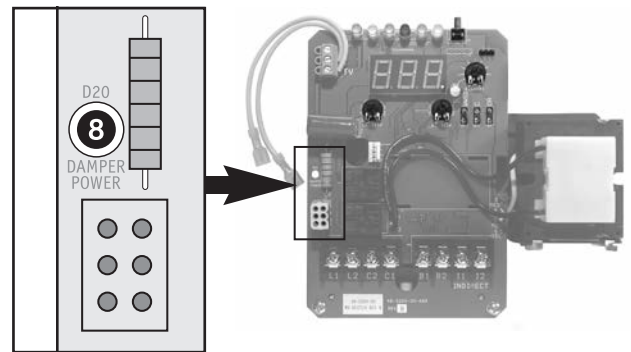

8 DAMPER POWER LED

Indicates the control is energizing the vent damper. For applications where the vent damper is not plugged into the HydroStat, the LED indicates that the burner circuit (B1 - B2) is powered.

If this LED is on and the burner is not firing:

1. Make sure the plug connection (or jumper, on boilers where vent damper plug is not used) is secure.
2. Make sure that the plug connection at the vent damper end is secure and oriented correctly.
3. Make sure damper motor turns
4. Verify the damper end switch has closed

DANGER Carbon Monoxide Hazard: If the burner fires when the vent damper is not fully opened or there is any other blockage in the flue, dangerous flue products, such as carbon monoxide, will escape into the living space causing severe personal injury or death. The flue as well as the vent damper must be checked for proper operation before allowing the system to operate.

MAINTENANCE

Remove the Electro-Well from the heating system every five years and clean any scale or sediment deposits from all parts that are exposed to the boiler water. After cleaning, reinstall the well using pipe sealing compound. **Teflon tape is not recommended.**

TROUBLESHOOTING

Burner Will Not Fire	See Flow Chart 1, page 11
Burner Will Not Shut Down	See Flow Chart 2, page 12
Temperature Display Exceeds High Limit Setting	Under normal operation, boiler temperature will continue to rise after the control shuts off the burner. This condition, known as “thermal stacking”, results from hot boiler surfaces continuing to release heat into the boiler water.
No or Insufficient Domestic Hot Water	For boilers equipped with a tankless coil, make sure the low limit setting on the HydroStat is set properly. NOTE: If the low limit setting is dialed fully counter clockwise, it will shut off the low temperature maintenance feature and will function as a cold start control. If installed with an indirect water heater, verify that the end switch in the relay box controlling the indirect water heater is connected to the I1-I2 terminals. This will ensure that the domestic water calls are prioritized. (see “Heating and Indirect Water Heater” on page 4).
Low Water Light (Red LED) is On or Blinking	 <p>WARNING: A low water condition is a serious and potentially dangerous condition. Do not attempt to add water to a hot boiler. Allow the boiler to fully cool before adding water.</p> <p>When Installed on an Electro-Well™</p> <p>When the LOW WATER light is on, this indicates that the control is not detecting water in the boiler. When the LOW WATER light is blinking, this indicates that the control has been programmed to provide low water lock-out protection and is currently locked out (see Manual Reset Low Water Cut-Off on page 6). Pressing the TEST/SETTINGS button after the low water condition is resolved will reset the lock-out condition.</p> <ol style="list-style-type: none"> 1. If the light is on and the heating system is filled with water, pull the sensor out of the well and inspect it. Make sure that the metal clip is protruding enough to come in contact with the inside of the well tube. Check that the well does not have excessive build-up of heat transfer grease that may interfere with the clip contacting the well. 2. Remove well and examine for excessive residue build-up. Clean and re-install. <p>When Installed on a Standard Immersion Well</p> <p>If either LWCO LED lights are illuminated and the control is installed on a standard immersion well, this is a false reading caused by a loss of continuity between the sensor and the inside of the well tube. Follow steps 1 and 2 (above) to ensure that the metal sensor head is making good contact with the inside surface of the copper well.</p>
Boiler Will Not Maintain Low Limit Temperature	Check for overlapping high temperature setting. If the high limit setting is set below the low limit setting, the control will default to the high limit setting and the corresponding high limit differential setting.
House Will Not Get or Stay Warm	<ol style="list-style-type: none"> 1. Check for air-bound radiators. 2. Check thermostat settings including heat anticipator settings (common on non-digital thermostats). 3. Check the Economy setting. The Economy feature, much like outdoor reset controls, lowers average boiler temperature and can slow or, in some cases, prevent the house from coming up to temperature. Move to a lower setting (see “Setting the Economy Feature” on page 4).
Circulator Contacts C1 and C2 Not Energized on Call for Heat	If the Circulator Hold Off is active (see page 7), check to see that boiler water is at or above 125°F. On a call for heat, the control will not permit the circulator to operate if the boiler water temperature is below 125°F.
All LED Lights and Temp Display are Blinking	If the LED lights and the temp display are blinking alternately, this indicates the control has sensed a boiler temperature of 250°F. When this occurs, the control pulses the burner relay and then shuts down and locks out the burner until the temperature falls below 210°F. The system should be analyzed to determine the cause of the overheating condition. Check that the sensor is inserted all the way into the well so it can accurately sense the temperature of the boiler water. Check system wiring and operation as well as the control’s high limit setting. If the cause of the overheating condition cannot be determined, the control should be replaced.

Troubleshooting Flow Chart 1 – Burner Will Not Fire

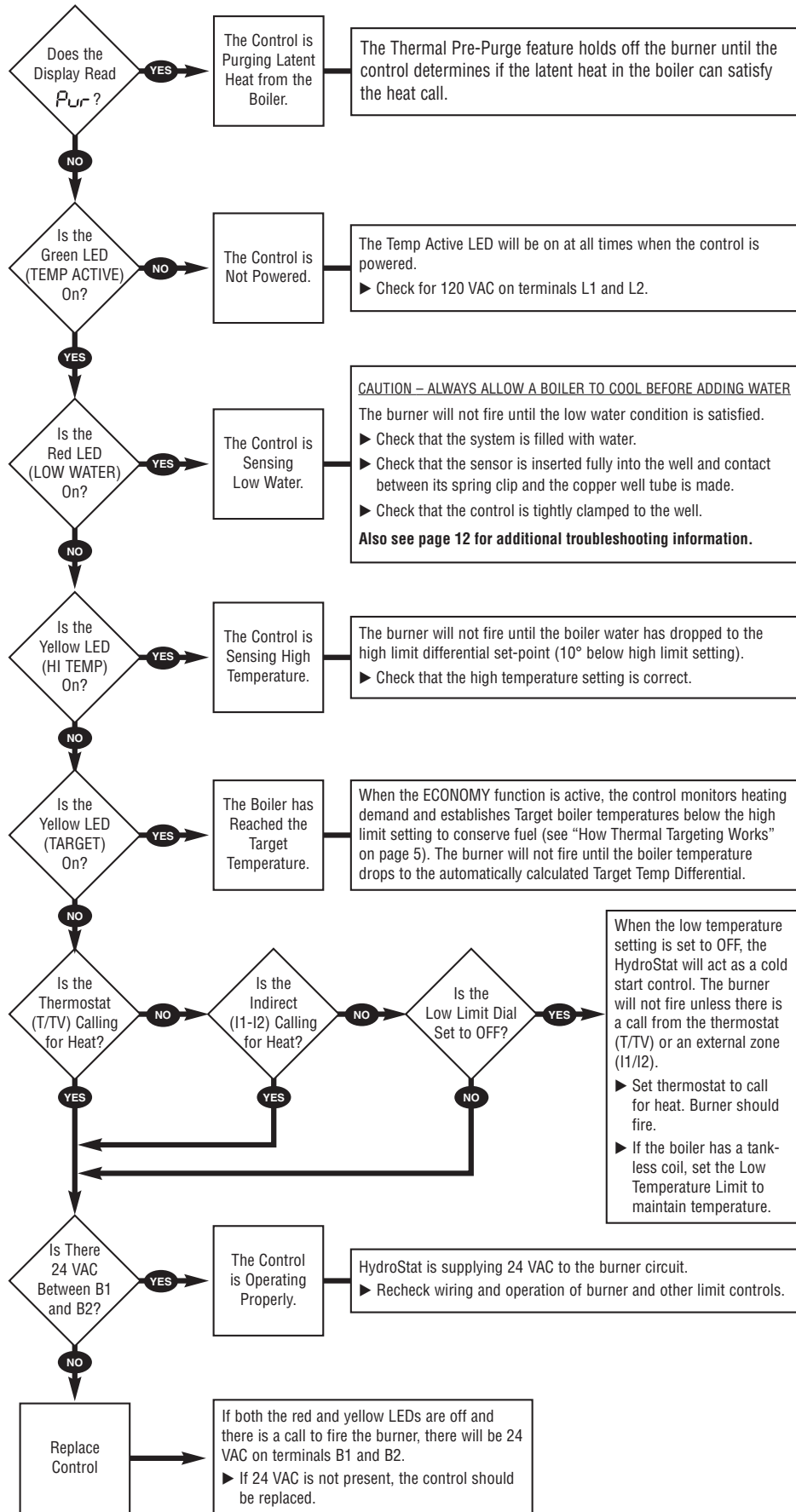

Troubleshooting Flow Chart 2 – Burner Will Not Shut Down

